

Introduction

Barr Marine By EDM

100 Douglas Way

P.O. Box 190

Natural Bridge Station, VA 24579

Toll Free: (866) 255-9265 Phone: (540) 291-4180

Fax: (540) 291-4185

Barr Marine by EDM, a pioneer in the marine engine component replacement field, was founded in 1933 by Horatio W. Barraclough, Sr. under the name Marine Salvage. Among the first products engineered and manufactured were replacement exhaust manifolds for conversions of the famous 4-cylinder Model "A" Ford and Pierce Arrow 6-cylinder engines, along with the Buick and Chrysler straight 8 cylinder engines. Additional water-cooled manifolds followed throughout the 1930s for such engines as the 4-cylinder Willy's, flathead Ford V8, and the 16-cylinder Cadillac.

Operating his shop in the Philadelphia area, Barraclough Sr., joined by his four sons, saw the firm grow until the outbreak of World War II. As the sons left for military service, the business suspended almost all operations for the duration of the war. During this period, Barraclough Sr. moved the company to Port Republic, New Jersey, and remained active in the marine salvage business.

After the war, the four sons, Wallace, Robert, Russell, and Richard, started up their own operation, again in the Philadelphia area and incorporated as Barr Marine Products Co., the name that continues in use today. In addition to supplying the marine field with replacement exhaust system parts and engine conversions, Barr started manufacturing Barr diesel and gas engines, using the Chevrolet and Oldsmobile V8 gas engines and Ford and GMC engines for diesel.

As the company expanded, they moved several times into larger quarters until in 1972 a new plant was built to their own specifications in Bensalem, PA. This modern, one-story building housed offices, warehouse and manufacturing facilities. Here Barr began to phase out engine manufacturing and engine conversions. Recognizing the need for marine exhaust manifold and riser replacements that were of superior quality, but still economically priced, they began to specialize in marine exhaust systems and soon become known as "The Manifold People".

Joined by the third generation of the Barraclough family, Barr Marine continued to grow, and in the fall of 1980 was purchased by Barr International Industries, Inc. Barr Marine was sold to EDM, Inc. in the winter of 2001.

Barr Marine by EDM looks to the future with great optimism. They are now offering the pleasure boat and work boat industries an ever expanding line of replacement exhaust manifolds, exhaust risers and connectors, and other related engine parts.

During the operation of any marine engine-gas or diesel-exhaust gases are produced and must be removed from the engine and conducted outside the boat. While there are two basic exhaust systems, wet and dry, the wet system is the one most often found in pleasure boats as well as many work boats. This system mixes the exhaust gases with engine-cooling water and then discharges them through the transom of the boat via an exhaust line.

Exhaust Manifold

Attached to the engine is an exhaust manifold with its exhaust inlets matching the exhaust outlet ports of the engine. Circulating cooling water through the water jacket surrounding the exhaust gas chamber cools this manifold.

Exhaust Connector

At the exhaust end of the manifold is an exhaust connector. This connector is an intermediary between the manifold and an exhaust hose or pipe. This connector also mixes the exhaust gases with water to further cool the gases, and it operates as a means for directing the gas and water outflows so that a connection can be made between the manifold and the exhaust tubing.

Particular attention must be paid to the relative height difference between the center line of the exhaust end of the center line of the transom overboard exhaust fitting, the exhaust connector can be an exhaust dump or drop of a convenient angle.

In those instances where the manifold is not appreciably above or is below the overboard fitting, an exhaust riser is used. By design, the riser acts as a dam to keep both exhaust-cooling water and seawater from back flooding into the engine and destroying it.

Back Pressure

From an engineering viewpoint, the most critical design requirement for exhaust systems is to limit the backpressure on the engine to a minimum. Backpressure is the pressure that builds up in the exhaust manifold engine exhaust outlets. The lower the pressure in the exhaust, the more efficient the operation of the engine. Low backpressure is achieved by designing exhaust passages to minimize resistance to the flow of gases and to prove for a uniform gas flow away from all cylinders.

Barr manifolds and exhaust connectors are designed to minimize backpressure. In many cases, after replacing an OEM manifold with Barr replacement parts, more r.p.m.'s are achieved.

Replacement Exhaust Systems

When the need arises to replace an OEM-installed manifold and/or exhaust connector, one of the three situations will exist: replacement of both manifold and connector, replacement of the manifold only, or replacement of the exhaust connector only.

When replacing both manifold and connector, normally there are no problems in matching, and connection to existing exhaust lines is usually very easy. When replacing just the manifold or just the exhaust connector, problems can arise in matching the replacement part to the existing part. Barr recognizes these problems and, wherever possible, has provided the necessary adaptors for connecting a Barr replacement manifold or exhaust connector to original exhaust parts.

It's The Law - Know Your Rights!

Barr Marine By EDM

100 Douglas Way

P.O. Box 190

Natural Bridge Station, VA 24579

Toll Free: (866) 255-9265 Phone: (540) 291-4180

Fax: (540) 291-4185

Consumers are protected from manufacturers who attempt to unfairly chain the purchasers of their products to the continued purchase of their maintenance and repair products and authorized services. Congress has provided consumers with this protection under the Magnuson-Moss Warranty Act as well as specific provisions of the Federal Trade Commission Improvement Act.

It's against the law for an original equipment manufacturer to inform consumers that their warranty would be void should they use other than genuine replacement parts or if service were to be preformed by anyone other than an authorized "OEM" dealer unless, of course, such parts and service were to be performed "Free of Charge" under the terms of the warranty.

The laws were enacted to grant the consumers and dealers the basic right to select replacement parts from competent manufacturers without fear of jeopardizing their warranty. The law directly provides the consumer the right of choice, the right to an affordable alternative choice of manufactured product. Of course, the original equipment manufacturer is not responsible for product failures or damages caused by product failures of product manufactured by others. Such damages become the responsibility of the company providing such products under the terms of their own warranties. Barr Marine by EDM originated the three-year limited warranty that has recently become the standard for all others to follow. Our warranty can be found in our catalog directly following this notice.

Barr Marine by EDM has been a manufacturer of Marine Engine Parts for seventy-three years. The company has and continues to manufacture marine engine parts for many of the original equipment manufacturers. For years, we have represented the affordable alternative choice for your needs. We thank you for your continued support!

Barr Marine By EDM

100 Douglas Way

P.O. Box 190

Natural Bridge Station, VA 24579

Toll Free: (866) 255-9265 Phone: (540) 291-4180

Fax: (540) 291-4185

Three Year Limited Warranty

Three-year warranty on exhaust manifolds, risers and exhaust connectors manufactured by Barr Marine by EDM.

Unless specifically indicated otherwise, Barr Marine by EDM (“Manufacturer”) warrants this product against defects in workmanship and material for three years from date of purchase by the original purchaser to the extent that Manufacturer will, at its option, replace or repair the product or any part thereof which in Manufacturer’s judgment has such a defect, provided that written notice of such defect is received by Manufacturer at the address above within three years after date of purchase by the original purchaser. The Buyer shall return the product to Manufacturer, at Buyer’s expense to the address above. Manufacturer’s obligation does not include any cost of removal or reinstallation, and this warranty shall not apply if the product has been misused, abused, altered, neglected or improperly installed or repaired work by anyone other than the Manufacturer was a cause of the defect.

This Warranty does not extend to Barr Marine by EDM products used in racing or “high performance” applications. Any work done by others without notifying Barr Marine by EDM in advance of such performance and without written authorized shall automatically terminate buyer’s rights or remedies against seller.

The warranties set forth above are the sole express warranties made by manufacturer with respect to this product or any thereof.

Any implied warranties, including without limitation any warranties of fitness or of merchantability, are hereby expressly limited in duration to the three-year period of this warranty.

Some states do not allow limitations on how long an implied warranty lasts, so the above limitation may not apply to you.

This warranty does not extend to anyone other than the original purchaser.

Notwithstanding anything to the contrary herein contained, if this product is specifically excluded or used for commercial purposes, rental, or other income-producing activities, then the duration of this warranty shall be one year from the date of purchase.

Manufacturer reserves the right to improve its products through changes in design or materials without being obligated to incorporate such changes in products of prior manufacture and to make changes at any time in design, materials, or parts of products without obligation or liability to owners or products of prior manufacture.

Some states do not allow the exclusion or limitation of incidental or consequential damages, so the above limitation or exclusion may not apply to you.

This warranty gives you specific legal rights, and may also have other rights, which vary from state to state.



Barr Marine By EDM

100 Douglas Way

P.O. Box 190

Natural Bridge Station, VA 24579

Toll Free: (866) 255-9265 Phone: (540) 291-4180

Fax: (540) 291-4185

Complete List of Barr Conversion Manifolds

ENGINE APPLICATION

Buick V8: 364, 401 & 425 C.I.D.; 1957-66
Buick V8: 400, 435 & 455 C.I.D.; 1967-76
Buick V6: 198, 225 & 231 C.I.D.; All Models
Caterpillar V8 Diesel: 636 C.I.D.; Naturally Aspirated
Chevrolet 4 Cylinder: 153 & 181 C.I.D.
Chevrolet 6 Cylinder: 194, 230, 250 & 292 C.I.D.; 1962-75
Chevrolet V8 OHV: 235 & 283 C.I.D.; 1955-57
Chevrolet V8 OHV: 305, 307, 327, 350 & 400 C.I.D.; 1962 Up
Chevrolet V8 OHV: 348 & 409 C.I.D. 1958-65
Chevrolet V8 OHV: 396, 427 & 454 C.I.D.; 1966 Up
Chevrolet V8 OHV: 396, 427 & 454 C.I.D.; 1966 Up
Chevrolet V8 OHV: 396, 427 & 454 C.I.D.; 1966 Up
Chevrolet V8 : Fits All Small Block Chevy 283-400 C.I.D.
Chevrolet V8 : Fits All Small Block Chevy 283-400 C.I.D.
Detroit Diesel V8: 6.2 Liter
Detroit Diesel V8: 8.2 Liter
Detroit Diesel: 3/71 & 6V/71
Detroit Diesel: 4/71 & 8V/71 (Will Fit Early 92 Series/Call Barr)
Detroit Diesel: 6/71 & 12V/71 (Will Fit Early 92 Series/Call Barr)
Ford Falcon, Comet 6 Cylinder 144 & 177 C.I.D.; 1960-64
Ford V8: Fits 260, 289, 302 & 351 C.I.D. (Windsor Models Only)
Ford, Lincoln, Mercury: 460 C.I.D.; All Years
Ford & Mercury V8 OHV: 239, 292 & 312 C.I.D.
Ford & Mercury V8: 221, 260 & 289 C.I.D.; 1962 Up
Ford & Mercury V8: 302 & 351 C.I.D. Windsor 2 Barrel Carburetor
Ford & Mercury V8 OHV: 332, 352, 390 and 427 C.I.D. ;1958-67
Oldsmobile V8 Diesel: 260 & 350 C.I.D.; 1978 Up
Oldsmobile Rocket V8: 330, 350, 400, 425 & 455 C.I.D.

PART NUMBER

BV-1-57
BV-1-67
BV6-1-75
CAT-1-3208
MC-1-0120
C-1-6364
CHV-1-5557
CHV-1-63
CHVA-1-58
CHVA-1-65
CHVA-1-84**
CHVA-1-92#
CHV-1-83**
CHV-1-92#
CHD-1-82
DD-1-501
DD-1-3710
DD-1-4710
DD-1-6710
FC-1-60
FM-1-83***#
FM 1 7275
FM-1-5457
FM-1-6268
FM-1-6970##
FE-1-58
OR-1-73
OR-1-73

****CENTER RISER MANIFOLD**

#ALUMINUM MANIFOLD

##WILL NOT FIT CLEVELAND ENGINES

Manifold End Plate and Gasket Identification Listing

Barr Marine By EDM

100 Douglas Way

P.O. Box 190

Natural Bridge Station, VA 24579

Toll Free: (866) 255-9265 Phone: (540) 291-4180

Fax: (540) 291-4185

Manifold Part #	Front End Plate	Gasket	Exhaust End Plate	Gasket	Header Adaptor
BV-1-57	1-0032	1-0019	1-0025	1-0019	1-0001
BV-1-67	1-0032	1-0019	1-0025	1-0019	1-0001
BV6-1-75	1-0092	1-0022	1-0024##	1-0022	1-0000
C-1-6364	1-0032	1-0019	1-0025	1-0019	1-0001
C6-1-M7M27	1-0056	1-0062	1-0067*	1-0068	1-0007
C6-1-M47	1-0057	1-0062	1-0067*	1-0068	1-0007
CAT-1-3208	DA-1-6371L2/R2	1-0019	1-0025	1-0019	1-0001
CHD-1-82	1-0036	1-0019	1-0025	1-0019	1-0001
CHV-1-5557	1-0042	1-0022	1-0024	1-0022	1-0000
CHV-1-63	1-0032	1-0019	1-0025	1-0019	1-0001
CHVA-1-58	1-0032	1-0019	1-0025	1-0019	1-0001
CHVA-1-65	1-0032	1-0019	1-0025	1-0019	1-0001
CM-1-5665	1-0092	1-0022	1-0024##	1-0022	1-0000
D-1-M6M26	1-0056	1-0062	1-0067*	1-0068	1-0007
D-1-M46SP	1-0057	1-0062	1-0067*	1-0068	1-0007
D1-M46ST	1-0057	1-0062	1-0067*	1-0068	1-0007
DD-1-501	1-0036	1-0019	1-0025	1-0019	1-0001
FC-1-60	1-0042	1-0022	1-0024	1-0022	1-0000
FE-1-58	1-0032	1-0019	1-0025	1-0019	1-0001
FM-1-5457	1-0031	1-0022	1-0024	1-0022	1-0000
FM-1-6970	1-0032	1-0019	1-0025	1-0019	1-0001
FM-1-7275	1-0032	1-0019	1-0025	1-0019	1-0001
GR-1-162**	1-0059	1-0060	GR-1-0001**	N/A	N/A
GR-1-175**	1-0059	1-0060	GR-1-0001**	N/A	N/A
GR-1-226	1-0009	1-0011	GR-1-0001**	N/A	N/A
GR-1-3273L	GR-1-0005L	GR-1-0006	GR-1-0003L	GR-1-0006	1-0069
GR-1-3273R	GR-1-0005R	GR-1-0006	GR-1-0003R	GR-1-0006	1-0069
GR-1-3274L	GR-1-0005L	GR-1-0006	GR-1-0002L	GR-1-0006	1-0002
GR-1-3274R	GR-1-0005R	GR-1-0002R	GR-1-0002R	GR-1-0006	1-0002
GR-1-6470	GR-1-6470A	1-0019	1-0036##	1-0019	1-0001
INT-1-5457L	1-0072	1-0022	1-0024##	1-0022	1-0000
INT-1-5457R	1-0074	1-0022	1-0024##	1-0022	1-0000
INT-1-58L	1-0077	1-0019	1-0025##	1-0019	1-0001
INT-1-58R	1-0076	1-0019	1-0025##	1-0019	1-0001
INT-1-6268L	1-0072	1-0022	1-0024##	1-0022	1-0000
INT-1-6268R	1-0074	1-0022	1-0024##	1-0022	1-0000
MC-1-0120	1-0075	1-0022	1-0092	1-0022	NOT REQ'D
MC-1-6364	C-1-6365B	1-0019	1-0036	1-0019	NOT REQ'D
OF-1-60	1-0036	1-0019	1-0025	1-0019	1-0001
OR-1-73	NOT REQ'D	NOT REQ'D	1-0080	1-0082	1-0081
V6D-1-478	V8D-1-0002	V8D-1-0003	V8D-1-0001##	V8D-1-0003	V8D-1-0004
V8D-1-637	V8D-1-0002	V8D-1-0003	V8D-1-0001##	V8D-1-0003	V8D-1-0004

*NOTE: MANIFOLDS WITH FOUR BOLT STYLE AND FLANGES REQUIRE ADAPTOR # 1-0061 AND GASKET 1-0062 BETWEEN MANIFOLD AND END PLATE.

NOTE: PART # GR-1-0001 IS A REPLACEMENT FOR THE ORIGINAL GRAY THREADED FLANGE AND IS NOT SUPPLIED WITH THE MANIFOLD. MANIFOLDS MARKED () THUS CAN BE USED WITH THE ORIGINAL GRAY EXHAUST FITTING.

HEADER ADAPTOR FURNISHED INSTEAD OF EXHAUST END PLATE.



MerCruiser 4 Cylinder 181 C.I.D. 140 H.P. 3.0L and 3.0LX Models

All Models 1990 and Up (Vortec Style Head)
Log Style Direct Replacement



MC 1 860235



MC 20 12076

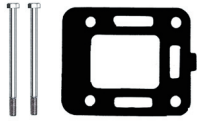

MC 20 12076P



MC47 27 99777-2



50 170 207



MC 50 22 845175



MC 50 22 862065



MC47 27 807982



MC47 27 815528



MC 50 10 806300



MC 50 10 53728



MC 50 11 24883



MC 50 11 862902



MC 50 12 20553



MC 50 22 862065



MC 50 22 806608



MC 50 25 32506



MC 50 32 14797

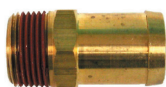

50 512 020



MC 50 865549



MC 50 23 861634

MC 1 860235	Direct replacement exhaust manifold. Replaces MerCruiser part # 860235A04.
MC 20 12076	Direct replacement exhaust riser. Replaces MerCruiser part # 12076A2.
MC 20 12076P	Exhaust riser mounting kit.
50 170 207	3/8" -16 X 3/4" Hex Head Cap Screw (for mounting lifting eye).
50 512 020	Fitting, 3/4" N.P.T. X 1" hose.
MC47 27 99777-2	Replacement exhaust riser to manifold gasket. Supersedes MerCruiser part # 27-52076 and 27-99777.
MC47 27 807982	Replacement carburetor to intake/exhaust manifold gasket.
MC47 27 815528	Replacement cylinder head to exhaust manifold gasket.
MC 50 865549	Lifting eye.
MC 50 10 53728	Replacement 3/8" -16 X 4 5/8" screw.
MC 50 10 806300	Replacement 3/8" X 5 3/8" stud.
MC 50 11 24883	Replacement nut.
MC 50 11 862902	Replacement nut.
MC 50 12 20553	Replacement washer.
MC 50 22 806608	Drain plug.
MC 50 22 845175	Replacement reducer bushing, 3/4" to 3/8".
MC 50 22 862557	Replacement bushing, 3/8 X 1/2 NPT.
MC 50 22 862065	Replacement 90 degree adaptor assembly.
MC 50 25 32506	Replacement O-Ring.
MC 50 32 14797	Replacement fuel line.
MC 50 23 861634	Replacement cooling water hose, formed.

Note:

Manifold includes all plugs, gaskets and mounting hardware to head. Risers include plugs, gasket and mounting hardware to mount to manifold.

BARR
MARINE BY EDM

SUPPLEMENT

OMC/VOLVO V8- 5.0L and 5.8L Cobra

All Models (Carbureted)
Center Riser Direct Replacement

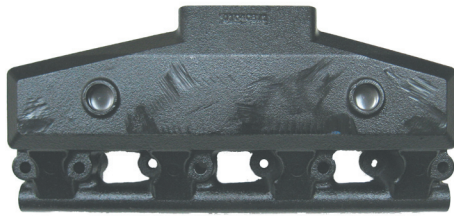

OMC 1 3852347

OMC-1-3852347	Direct replacement exhaust manifold. Replaces Volvo part # 3852347.
OMC-20-913784	Direct replacement exhaust riser/elbow. Replaces OMC # 913784 and Volvo part # 3863061 (New Style).
OMC-20-913784P	Exhaust riser/elbow mounting package.
FM 47 0000	Exhaust manifold to cylinder head gasket.
OMC47-913783	Direct replacement exhaust riser/elbow to manifold gasket.
50-512-017	Replacement 1/2" N.P.T. to 1" hose (straight)/brass hose fitting.

Note:

Manifold includes all plugs, gaskets, hose fitting and mounting hardware to head. Risers include plugs, gasket and mounting hardware to mount to manifold.

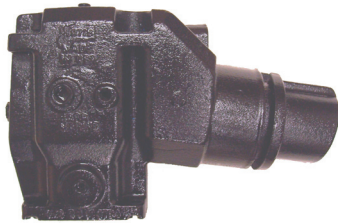

OMC 20 913784

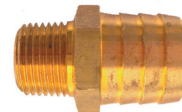

50 512 017

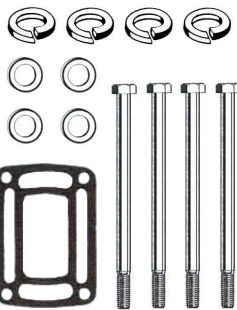

OMC 20 913784P



FM 47 0000

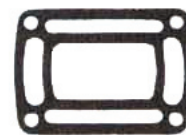

OMC47 913783

**Warning: Barr Riser Shown Only Fits Carbureted Ford Engines!
Will Not Directly Replace Volvo Part #'s 3855271 (port) Or
3855269 (stbd) Risers for EFI Models**



SUPPLEMENT

OMC/VOLVO V6- 4.3 Liter Cobra

All Models

Center Riser Direct Replacement



OMC 1 3857656

OMC-1-3857656	Direct replacement exhaust manifold. Replaces Volvo part # 3857656.
OMC-20-913784	Direct replacement exhaust riser/ elbow. Replaces OMC # 913784 and Volvo part # 3863061 (New Style).
OMC-20-913784P	Exhaust riser/elbow mounting package.
MC47-27 99757	Exhaust manifold to cylinder head gasket.
OMC47-913783	Direct replacement exhaust riser/ elbow to manifold gasket.
50-512-017	Replacement 1/2" N.P.T. to 1" hose (straight)/brass hose fitting.



OMC 20 913784

Note:

Manifold includes all plugs, gaskets and mounting hardware to head. Risers include plugs, gasket and mounting hardware to mount to manifold.



OMC 20 913784P



50 512 017



MC47 27 99757

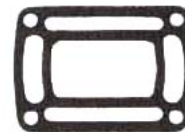

OMC47 913783

Barr Marine Diesel Engine Riser

20-0094	Versatile 1 1/2" N.P.T. exhaust riser. Approx. 10 lbs in weight; Gray Iron.
20-0101	Versatile 1 1/2" N.P.T. exhaust riser. Approx. 2 1/2 lbs. in weight; Aluminum.
50-090-150	1 1/2" N.P.T. Pipe Plug

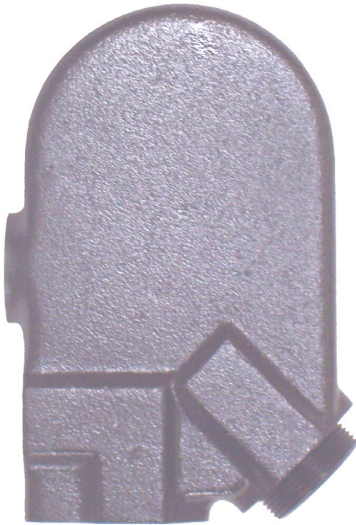

20 0094

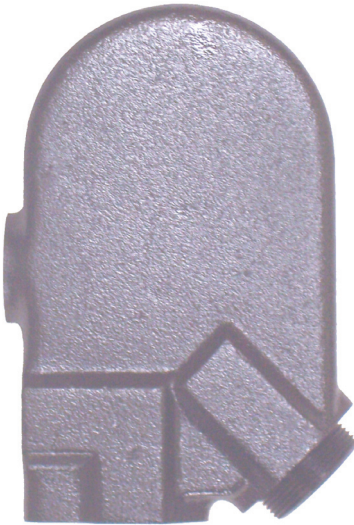

20 0101



50 090 150

Chevrolet V8-283, 302, 305, 307, 327 and 350 C.I.D. All Models Center Riser Generic Aluminum



CHV 1 92

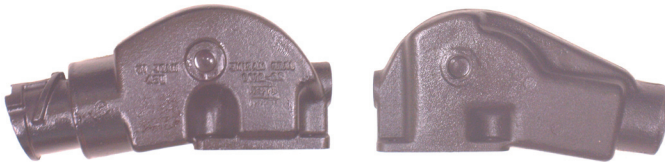

20 0107

20 0108



20 0087P

20 0093P

20 0089P



CHV 1 92P



20 0107P



1 0105



1 0107



CHV 47 0000

CHV-1-92	Water cooled center discharge manifold to fit the small block GM engine (3/4" N.P.T. cooling hose connections). All years.
20-0108	Water cooled center discharge riser (3/4" N.P.T. cooling hose connection). Standard for use with 3" I.D. exhaust hose.
20-0107	Water cooled center discharge riser (3/4" N.P.T. cooling hose connection). Standard for use with 4" I.D. exhaust hose.
1-0105	Center riser manifold-to-riser gasket for fresh water cooling.
1-0107	Center riser manifold-to-riser gasket (raw water cooling).
20-0107P	Riser mounting package for both 20-0107 and 20-0108.
20-0087P	90 degree exhaust elbow adaptor (includes adaptor, hose and clamps). For use with 3" I.D. exhaust hose.
20-0089P	30 degree exhaust elbow adaptor (includes adaptor, hose and clamps). For use with 3" I.D. exhaust hose.
20-0093P	90 degree exhaust elbow adaptor (includes adaptor, hose and clamps). For use with 3 1/2" or 4" I.D. exhaust hose.
CHV-1-92P	Manifold mounting package (includes bolts and pipe plugs).
CHV-47-0000	Manifold to cylinder head gasket.

Note:
Manifold includes CHV 1 92P (mounting package to head) and risers include 20 0107P (mounting package to manifold).

The center riser is a two-piece aluminum manifold/riser ideally suited for replacement use where riser protection is required. The Barr Center Riser aluminum manifold/riser uses flexible exhaust hose which facilitates connection to existing exhaust lines. All elbows (cast iron) can swivel inboard or outboard for perfect fit. The Barr Center Riser aluminum manifold/riser is designed to limit back pressure on the engine, resulting in more efficient engine performance. The manifold and riser can be reversed and will fit either side of the engine.

The Barr Center Riser aluminum manifold/riser is cast of 356 T6 aluminum, well suited for fresh water marine applications. Barr Marine's Center Riser aluminum manifold/riser come with a one year warranty. However, Barr Marine By EDM does not recommend use of this product in salt water applications and does not warrant this product in salt water due to extreme corrosion.

Chevrolet Big Block 427 and 454 C.I.D.

All Models Center Riser Generic Aluminum



CHVA 1 92

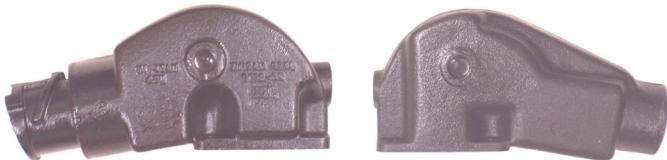

20 0107

20 0108



20 0087P

20 0093P

20 0089P



CHVA 1 92P



20 0107P



1 0105



1 0107



CHVA 47 0000

CHVA-1-92	Water cooled center discharge manifold to fit the big block GM engine (3/4" N.P.T. cooling hose connections). All years.
20-0108	Water cooled center discharge riser (3/4" N.P.T. cooling hose connection). Standard for use with 3" I.D. exhaust hose.
20-0107	Water cooled center discharge riser (3/4" N.P.T. cooling hose connection). Standard for use with 4" I.D. exhaust hose.
1-0105	Center riser manifold-to-riser gasket for fresh water cooling.
1-0107	Center riser manifold-to-riser gasket (raw water cooling).
20-0107P	Riser mounting package for both 20-0107 and 20-0108.
20-0087P	90 degree exhaust elbow adaptor (includes adaptor, hose and clamps). For use with 3" I.D. exhaust hose.
20-0089P	30 degree exhaust elbow adaptor (includes adaptor, hose and clamps). For use with 3" I.D. exhaust hose.
20-0093P	90 degree exhaust elbow adaptor (includes adaptor, hose and clamps). For use with 3 1/2" or 4" I.D. exhaust hose.
CHVA-1-92P	Manifold mounting package (includes bolts and pipe plugs).
CHVA-47-0000	Manifold to cylinder head gasket.

Note:

Manifold includes CHV 1 92P (mounting package to head) and risers include 20 0107P (mounting package to manifold).

The center riser is a two-piece aluminum manifold/riser ideally suited for replacement use where riser protection is required. The Barr Center Riser aluminum manifold/riser uses flexible exhaust hose which facilitates connection to existing exhaust lines. All elbows (cast iron) can swivel inboard or outboard for perfect fit. The Barr Center Riser aluminum manifold/riser is designed to limit back pressure on the engine, resulting in more efficient engine performance. The manifold and riser can be reversed and will fit either side of the engine.

The Barr Center Riser aluminum manifold/riser is cast of 356 T6 aluminum, well suited for fresh water marine applications. Barr Marine's Center Riser aluminum manifold/riser come with a one year warranty. However, Barr Marine By EDM does not recommend use of this product in salt water applications and does not warrant this product in salt water due to extreme corrosion.

Chris Craft V8-283, 302, 305, 307, 327 and 350 C.I.D. All Models Log Style Direct Replacement

The CC-1-07686 must not be used in 3 pass plumbing systems!

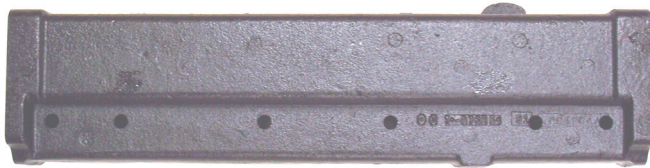

CC 1 07686



CC 20 08288



CC 20 08289



CC 20 07605



CC 20 07593

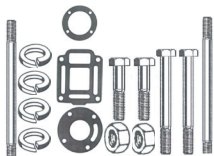

CC 20 0828P

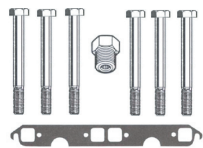

CC 1 07686P



CC 6 80



CHV 47 0000

CC-1-07686	Direct replacement water cooled manifold. Replaces Chris Craft part # 16.20-07686.
CC-20-08288	Direct replacement port side riser.
CC-20-08289	Direct replacement starboard side riser.
CC-1-07686P	Manifold mounting package.
CC-6-80	Pressure relief valve adaptor package for use with Chris Craft direct replacement risers as needed.
CC-20-07593	Riser/deflector plate. Replaces Chris Craft part #16.20-07593 (Order (2) of the appropriate gaskets according to your requirements).
CC-20-07605	Direct replacement exhaust elbow.
CC-20-0828P	Exhaust riser mounting package.
CC47-1650-05944	End cap gasket for all models except 283 C.I.D. with flywheel forward (Order (2) of the appropriate gaskets according to your requirements).
CC47-1650-06022	End cap gasket for 283 C.I.D. with flywheel forward (Order (2) of the appropriate gaskets according to your requirements).
CC47-1650-07290	Pressure relief valve housing gasket.
CC47-1650-07596	Riser/deflector plate gasket. Also requires gasket CC47-1650-07597 (Order (2) of the appropriate gaskets according to your requirements).
CC47-1650-07597	Riser/tail pipe gasket. Also requires gasket CC47-1650-07596 (Order (2) of the appropriate gaskets according to your requirements).
CC47-1650-07681	Adaptor/tail pipe gasket for 283 C.I.D. with flywheel forward (Order (2) of the appropriate gaskets according to your requirements).
CHV-47-0000	Manifold to cylinder head gasket.

Note:
Manifold includes all mounting hardware to head, gaskets and plugs. Risers include mounting gaskets and plugs only. Order CC 20 0828P to mount riser to manifold ((2) required per engine).



Chris Craft V8-283, 302, 305, 307, 327 and 350 C.I.D. All Models Generic

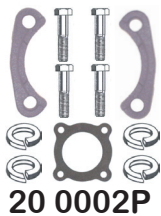
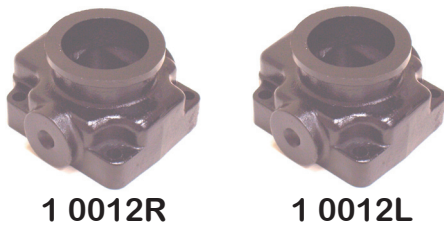
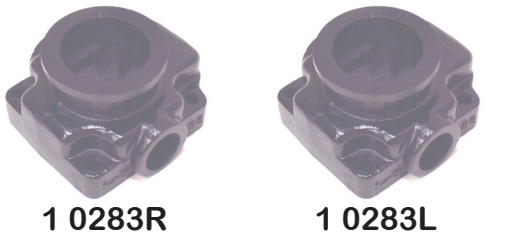
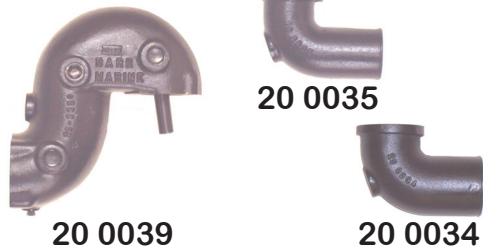

1-0012L	Adaptor for Chris Craft V8 283 C.I.D. Manifolds prior to Models F, G, K and Q (three pass manifold system) left side. Requires Chris Craft adaptor part #16.20-07602 (port side).
1-0012R	Adaptor for Chris Craft V8 283 C.I.D. Manifolds prior to Models F, G, K and Q (three pass manifold system) right side. Requires Chris Craft adaptor part #16.20-07064 (starboard side).
1-0283A	Adaptor for Chris Craft V8 283, 302, 305, 307, 327 and 350 C.I.D. Manifolds, Models F, G, and K (two pass manifold system). Not pictured.
1-0283L	Adaptor for Chris Craft V8 283, 302, 305, 307, 327 and 350 C.I.D. Manifolds, Model Q (single pass manifold system) left side.
1-0283L	Adaptor for Chris Craft V8 283, 302, 305, 307, 327 and 350 C.I.D. Manifolds, Model Q (single pass manifold system) right side.
20-0000	Swivel-type high discharge exhaust riser; 8 1/2" riser protection. Requires (1) mounting hardware kit #20-0002P per riser. Use only with 2 7/8" to 3" I.D. exhaust hose.
20-0002P	Mounting hardware kit.
20-0031	Swivel-type 90 degree exhaust elbow connector with internal water discharge. Accepts 2 1/2" to 3" I.D. exhaust hose. Requires (1) mounting hardware kit #20-0002P per elbow.
20-0034 or 20-0035	Exhaust connector #20-0035 (for 2 1/2" I.D. exhaust hose) or exhaust connector #20-0034 (for 3" I.D. exhaust hose). Connects to #20-0039 using (1) #20-0002P per connector.
20-0039	Fully jacketed swivel-type exhaust riser; 7" riser protection. Requires (2) mounting hardware kits #20-0002P ((1) kit to mount riser to manifold and (1) kit to mount elbows #20-0034 or #20-0035 to riser). Use for Models F, G, K, and Q; requires (1) CC-6-80 package.
20-0055	Swivel-type 30 degree exhaust elbow connector; fully jacketed. Accepts 2 1/2" or 3" I.D. exhaust hose. Requires (1) mounting hardware kit #20-0002P per elbow.
CC-6-80	Pressure relief valve adaptor package for Chris Craft V8 Models F, G, K, and Q. Use with #20-0039 riser.
CC47-1650-05944	End cap gasket for all models except 283 C.I.D. with flywheel forward (Order (2) of the appropriate gaskets according to your requirements).
CC47-1650-06022	End gasket for 283 C.I.D. with flywheel forward (Order (2) of the appropriate gaskets according to your requirements).

Chris Craft V8-283, 302, 305, 307, 327 and 350 C.I.D. All Models Center Riser Generic



CHV 1 83

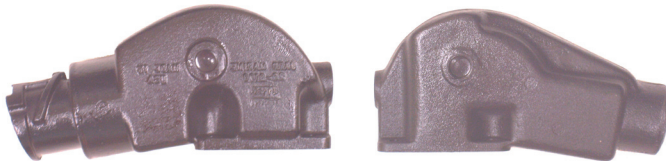

20 0100

20 0082



20 0097



20 0088P



20 0086P



20 0085P



20 0089P



CC 27 79



CHV 1 83P



20 0082P



CHV 27 0083

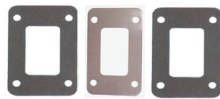

1 0104P

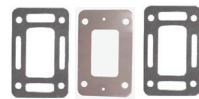

1 0106P

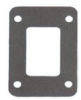

1 0105



1 0107



CHV 47 0000

CHV-1-83	Water cooled center discharge manifold to fit the small block GM engine (3/4" N.P.T. cooling hose connections). All years.
20-0082	Water cooled center discharge riser (3/4" N.P.T. cooling hose connection). Standard for use with 3" I.D. exhaust hose.
20-0100	Water cooled center discharge riser (3/4" N.P.T. cooling hose connection). Standard for use with 4" I.D. exhaust hose.
1-0104P	Adaptor package for fresh water cooled manifold (includes gaskets and block off plate).
1-0105	Center riser manifold-to-riser gasket for fresh water cooling.
1-0106P	Adaptor package for raw water cooling. Used in pre-heating applications (includes gaskets and block off plate with vent hole).
1-0107	Center riser manifold-to-riser gasket (raw water cooling).
20-0082P	Riser mounting package for both 20-0082 and 20-0100.
20-0082SS-P	Stainless steel mounting package (with brass plugs) for both 20-0082 and 20-0100. Not pictured.
20-0085P	Straight exhaust adaptor (includes adaptor, hose and clamps). For use with 2 1/2" I.D. exhaust hose.
20-0086P	90 degree exhaust elbow adaptor (includes adaptor, hose and clamps). For use with 2 1/2" I.D. exhaust hose.
20-0088P	30 degree exhaust elbow adaptor (includes adaptor, hose and clamps). For use with 2 1/2" I.D. exhaust hose.
20-0089P	30 degree exhaust elbow adaptor (includes adaptor, hose and clamps). For use with 3" I.D. exhaust hose.
20-0097	3" spacer block (complete with mounting hardware, gasket and 3/4" pipe plug). Capable of stacking.
CC-27-79	Alternator bracket. Use where engine water pump is mounted on the starboard side of the engine.
CHV-1-83P	Manifold mounting package (includes bolts and pipe plugs).
CHV-1-83SS-P	Stainless steel manifold mounting package (includes stainless bolts and brass plugs). Not pictured.
CHV-27-0083	Alternator bracket. Use where engine water pump is mounted on port side of engine below alternator.
CHV-47-0000	Manifold to cylinder head gasket.

Note:
Manifold includes all plugs, gaskets and mounting hardware to head. Risers include plugs, gasket and mounting hardware to mount to manifold.

Chris Craft V8-454 C.I.D.

All Models Center Riser Generic



CHVA 1 84

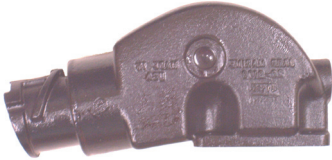

20 0100

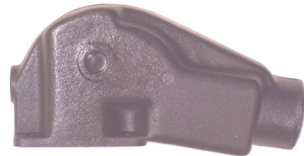

20 0082



20 0097



20 0084P

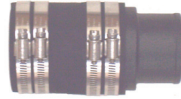

20 0085P



20 0086P



20 0087P



20 0088P



20 0089P



20 0092P

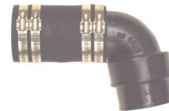

20 0093P



20 0082P



CHVA 1 84P

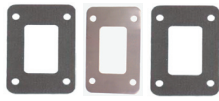

1 0104P

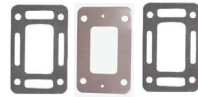

1 0106P



1 0105



1 0107



CHVA 47 0000

CHVA-1-84	Water cooled center discharge manifold to fit the big block GM engine (3/4" N.P.T. cooling hose connections). All years.
20-0082	Water cooled center discharge riser (3/4" N.P.T. cooling hose connection). Standard for use with 3" I.D. exhaust hose.
20-0100	Water cooled center discharge riser (3/4" N.P.T. cooling hose connection). Standard for use with 4" I.D. exhaust hose.
1-0104P	Adaptor package for fresh water cooled manifold (includes gaskets and block off plate).
1-0105	Center riser manifold-to-riser gasket for fresh water cooling.
1-0106P	Adaptor package for raw water cooling. Used in pre-heating applications (includes gaskets and block off plate with vent hole).
1-0107	Center riser manifold-to-riser gasket (raw water cooling).
20-0082P	Riser mounting package for both 20-0082 and 20-0100.
20-0082SS-P	Stainless steel mounting package (with brass plugs) for both 20-0082 and 20-0100. Not pictured.
20-0084P	Straight exhaust adaptor (includes adaptor, hose and clamps). For use with 3 1/2" I.D. exhaust hose.
20-0085P	Straight exhaust adaptor (includes adaptor, hose and clamps). For use with 2 1/2" I.D. exhaust hose.
20-0086P	90 degree exhaust elbow adaptor (includes adaptor, hose and clamps). For use with 2 1/2" I.D. exhaust hose.
20-0087P	90 degree exhaust elbow adaptor (includes adaptor, hose and clamps). For use with 3" I.D. exhaust hose.
20-0088P	30 degree exhaust elbow adaptor (includes adaptor, hose and clamps). For use with 2 1/2" I.D. exhaust hose.
20-0089P	30 degree exhaust elbow adaptor (includes adaptor, hose and clamps). For use with 3" I.D. exhaust hose.
20-0092P	45 degree exhaust elbow adaptor (includes adaptor, hose and clamps). For use with 3" I.D. exhaust hose.
20-0093P	90 degree exhaust elbow adaptor (includes adaptor, hose and clamps). For use with 3 1/2" or 4" I.D. exhaust hose.
20-0097	3" spacer block (complete with mounting hardware, gasket and 3/4" pipe plug). Capable of stacking.
CHVA-1-84P	Manifold mounting package (includes bolts and pipe plugs).
CHVA-1-84SS-P	Stainless steel manifold mounting package (includes stainless bolts and brass plugs). Not pictured.
CHVA-47-0000	Manifold to cylinder head gasket.

Note:

Manifold includes all plugs, gaskets and mounting hardware to head. Risers include plugs, gasket and mounting hardware to mount to manifold.

Chrysler V8 - 273, 318, 340, and 360 C.I.D.

All Models. 1986 and Up Center Riser Direct Replacement

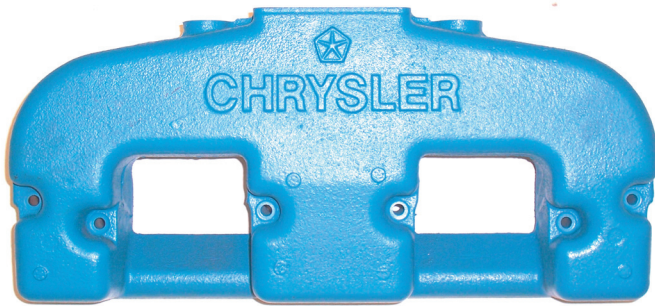

CM 1 4417063



534005

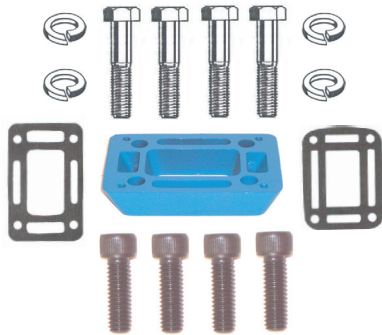

534002



CM47 4417232



534004

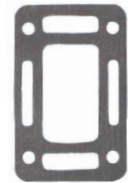

CM47 4417127



50 525 018



50 512 018



50 512 019



50 525 019

CM-1-4417063	Water cooled center discharge exhaust manifold to fit the small block Chrysler (1/2" N.P.T. cooling hose connections). Used during years 1986 and later.
534005	Generic riser designed to be mounted to the original Chrysler center riser exhaust manifold (for use with 3" I.D. exhaust hose/3/4" N.P.T. cooling hose connection).
534002	Adaptor kit (sold as shown) to fit the original Chrysler center riser exhaust manifold to the Barr style riser (part #534005). Adaptor must be used for Barr style riser.
534004	Riser gasket for raw water cooled manifolds (installed between manifold and adaptor plate).
50-512-018	1/2" N.P.T. X 3/4" hose (straight barb) brass fitting.
50-512-019	3/4" N.P.T. X 3/4" hose (straight barb) brass fitting.
50-525-018	1/2" N.P.T. X 3/4" hose (90 degree) brass fitting.
50-525-019	3/4" N.P.T. X 3/4" hose (90 degree) brass fitting.
CM47-4417127	Riser gasket for raw water cooled manifolds (installed between adaptor plate and riser).
CM47-4417232	Riser gasket for fresh water cooled manifolds (installed between manifold and adaptor plate).

Note: Manifold includes all mounting hardware, gaskets and plugs.

Chrysler V8 - 273, 318, 340, and 360 C.I.D.

All Models. 1966 and Up Log Style Direct Replacement

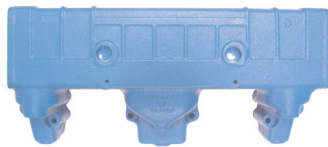

CM 1 6677A

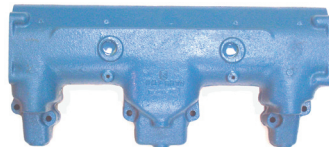

CM 1 6672A

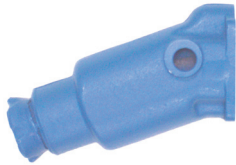

CM 20 6672



CM 20 6674



CM 20 2847405



CM 20 4142411



CM 20 9232



CM 20 2600402



CM 1 6672C



CM 1 6672B



CM 1 6672H



CM 20 6672P

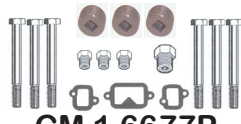

CM 1 6677P



CM 1 6672E

CM-1-6672A	Direct replacement water cooled manifold for model years 1966 to 1972.
CM-1-6677A	Direct replacement water cooled manifold for model years 1973 to 1986.
CM-20-2600402	Exhaust riser lower elbow. Direct replacement for Chrysler part # 2600402.
CM-20-2847405	90 degree exhaust elbow. Direct replacement for Chrysler part #'s 2847405 and 2469639.
CM-20-4142411	Exhaust riser/upper elbow. Direct replacement for Chrysler part #'s 3745639, 2847623, 2487404 and E9233M.
CM-20-6672	Fully jacketed 20 degree exhaust elbow. Accepts 3" I.D. exhaust hose. Direct replacement for Chrysler part # 3527794. Will mount directly to manifold or can be used with riser # CM-20-6674.
CM-20-6674	Fully jacketed exhaust riser. 6" riser protection. Direct replacement for Chrysler part # 2846689.
CM-20-9232	6" exhaust elbow high riser extension. Direct replacement for Chrysler part # E9232M.
CM-1-6672B	Front end plate without the water connector, (1) required per manifold (Chrysler part # 2846106). May require mounting kit # CM-1-6672B-P (shown on next page). Order the appropriate end flanges and fittings according to your requirements.
CM-1-6672C	Adaptor for rear end of manifold. Use with Barr style exhaust risers or elbows, (1) required per manifold.
CM-1-6672E	Copper water distribution tube, (1) required per manifold. Replaces original tube (Chrysler part # 3527781) where used. Will fit both manifold styles.
CM-1-6672H	Front end plate with 1/2" N.P.T. water connection. For use where water connection is made from the front of the manifold. Will replace Chrysler part # 3527869, (1) required per manifold. May require mounting kit # CM-1-6672B-P (show on next page). Will fit both manifold styles.
CM-1-6677P	Manifold to cylinder head mounting kit (Order (1) of the appropriate mounting kits according to your requirements).
CM-1-6677SS-P	Stainless steel manifold to cylinder head mounting kit (includes stainless studs, nuts, manifold to head gaskets and brass drain plugs). Not pictured.
CM-20-6672P	Mounting kit for exhaust elbow connector for raw water cooled manifold (includes bolts, gasket and pipe plug).

Note:

CM-1-6672A, CM-1-6677A, CM-20-6672, CM-20-6674 and CM-20-2847405 include all mounting hardware, gaskets and plugs. Swivel-style connector packages must be purchased separate for the corresponding riser/elbows. See next page for part numbers.

Chrysler V8 - 273, 318, 340, and 360 C.I.D.

All Models. 1966 and Up Log Style Direct Replacement

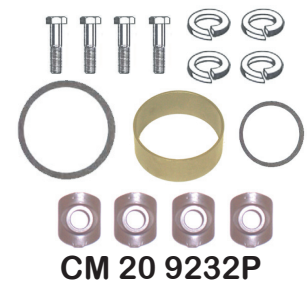
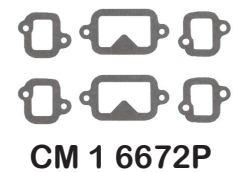
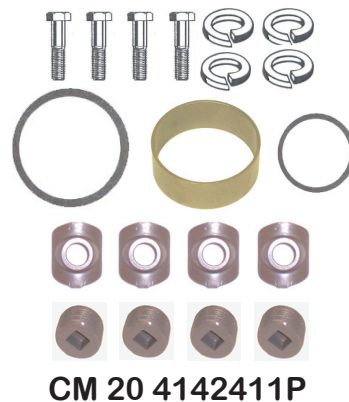
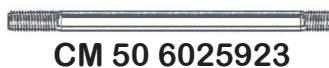
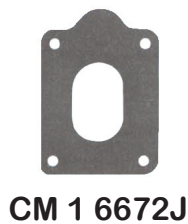
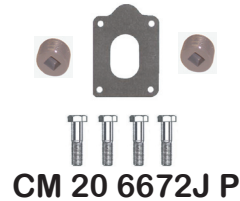

CM-1-6672D	End flange gasket for raw water cooled manifolds, (2) required per manifold. Replaces Chrysler part # 2847480. Will fit both manifold styles.
CM-1-6672J	End flange gasket for fresh water cooled manifolds, (1) required per exhaust end. Will fit both manifold styles.
CM-1-6672P	Manifold to cylinder head gasket set, (1) required per engine. Replaces Chrysler part # 3745220. Will fit both manifold styles.
CM-20-1947617	Exhaust elbow extension retainer.
CM-20-2600402P	Mounting kit for lower elbow riser (includes bolts, gasket and pipe plugs).
CM-20-2847405P	Mounting kit for exhaust elbow (includes bolts, gasket and pipe plugs).
CM-20-4142411P	Mounting kit for upper riser/elbow (includes sleeve, O-rings, retainers, bolts and pipe plugs).
CM-20-6672J-P	Mounting kit for exhaust elbow connector for fresh water cooled manifold (includes bolts, gasket, and pipe plugs).
CM-20-6674J-P	Mounting kit for exhaust riser for fresh water cooled manifold (includes bolts, gasket and pipe plug).
CM-20-6674P	Mounting kit for raw water cooled manifold (includes bolts, gasket and pipe plugs).
CM-20-9232P	Mounting kit for 6" extension (includes sleeve, O-rings, retainers and bolts).
CM-20-9224	Exhaust to elbow extension retainer sleeve.
CM-20-9225	Exhaust to elbow extension inner seal.
CM-20-9226	Exhaust to elbow extension outer seal.
CM-50-115729	Stainless steel exhaust manifold stud nut.
CM-50-602593	Stainless steel exhaust manifold stud.

Chrysler V8 - 361, 383, 400, 413, 426 and 440 C.I.D.

All Models. 1959 and Up Log Style Direct Replacement

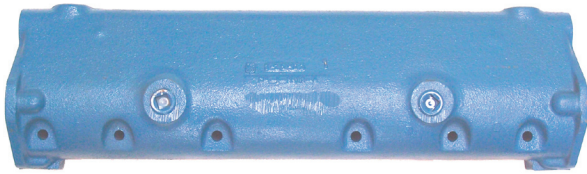

CM 1 5972A



CM 20 4142411



CM 20 9232



CM 20 9234



CM 1 5972B

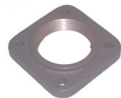

1 0067

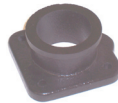

1 0007

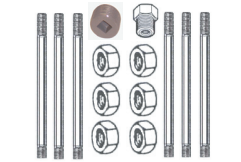

CM 1 5972SS P

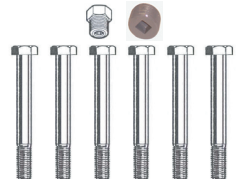

CM 1 5972G P

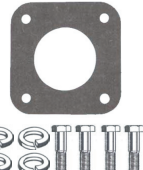

CM 20 9234P



CM 20 4142411P

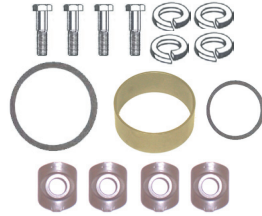

CM 20 9232P

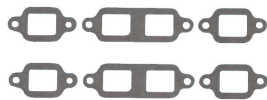

CM 1 5972P



CM 1 5972D



CM 20 9224



CM 1 5972C



CM 50 114942



CM 50 6023040



CM 20 1947617



CM 20 9226



CM 20 9225

CM-1-5972A	Direct replacement water cooled manifold for big block Chrysler.
CM-20-4142411	Exhaust riser/upper elbow. Direct replacement for Chrysler part #'s 3745639, 2847623, 2847404 and E9233M.
CM-20-9232	6" exhaust elbow high riser extension. Direct replacement for Chrysler part # E9232M.
CM-20-9234	Exhaust riser lower elbow. Direct replacement for Chrysler part # E9234M.
I-0007	Adaptor for rear end of manifold. Use with Barr style exhaust risers or elbow connectors.
I-0067	2 1/2" N.P.T. threaded exhaust end plate.
CM-1-5972B	Direct replacement front end plate.
CM-1-5972C	End plate gasket, (2) required per manifold.
CM-1-5972D	Copper water distribution tube. Replaces original tube where used.
CM-1-5972G-P	Manifold to cylinder head mounting kit (includes bolts, manifold to head gaskets and brass drain plug).
CM-1-5972P	Manifold to cylinder head mounting gasket set.
CM-1-5972SS-P	Manifold to cylinder head mounting kit (includes stainless steel studs and nuts, manifold to head gaskets and brass drain plugs).
CM-20-1947617	Exhaust elbow extension retainer.
CM-20-4142411P	Mounting kit for upper riser/elbow (includes sleeve, O-rings, retainers, bolts and pipe plugs).
CM-20-9224	Exhaust elbow to extension seal retainer sleeve.
CM-20-9225	Exhaust elbow to extension inner seal.
CM-20-9226	Exhaust elbow to extension outer seal.
CM-20-9232P	Mounting kit for 6" extension (includes sleeve, O-rings, clamps and bolts).
CM-20-9234P	Mounting kit for lower elbow riser (includes bolts, gasket and pipe plugs).
CM-50-114942	Stainless steel exhaust manifold stud nut.
CM-50-5023040	Stainless steel exhaust manifold stud.

Note:
 Manifold includes all mounting hardware to head, gaskets and plugs. Swivel-style connector packages must be purchased separate for the corresponding riser/elbows.

Crusader V8-283, 302, 305, 307, 327 and 350 C.I.D.

All Models Center Riser Generic



CHV 1 83

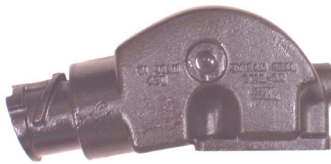

20 0100



20 0082



20 0097



20 0088P



20 0086P

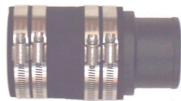

20 0085P



20 0089P



CHV 27 0083



CHV 1 83P



20 0082P



1 0104P

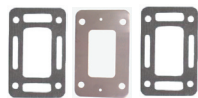

1 0106P



1 0105



1 0107



CHV 47 0000

CHV-1-83	Water cooled center discharge manifold to fit the small block GM engine (3/4" N.P.T. cooling hose connections). All years.
20-0082	Water cooled center discharge riser (3/4" N.P.T. cooling hose connection). Standard for use with 3" I.D. exhaust hose.
20-0100	Water cooled center discharge riser (3/4" N.P.T. cooling hose connection). Standard for use with 4" I.D. exhaust hose.
1-0104P	Adaptor package for fresh water cooled manifold (includes gaskets and block off plate).
1-0105	Center riser manifold-to-riser gasket for fresh water cooling.
1-0106P	Adaptor package for raw water cooling. Used in pre-heating applications (includes gaskets and block off plate with vent hole).
1-0107	Center riser manifold-to-riser gasket (raw water cooling).
20-0082P	Riser mounting package for both 20-0082 and 20-0100.
20-0082SS-P	Stainless steel mounting package (with brass plugs) for both 20-0082 and 20-0100. Not pictured.
20-0085P	Straight exhaust adaptor (includes adaptor, hose and clamps). For use with 2 1/2" I.D. exhaust hose.
20-0086P	90 degree exhaust elbow adaptor (includes adaptor, hose and clamps). For use with 2 1/2" I.D. exhaust hose.
20-0088P	30 degree exhaust elbow adaptor (includes adaptor, hose and clamps). For use with 2 1/2" I.D. exhaust hose.
20-0089P	30 degree exhaust elbow adaptor (includes adaptor, hose and clamps). For use with 3" I.D. exhaust hose.
20-0097	3" spacer block (complete with mounting hardware, gasket and 3/4" pipe plug). Capable of stacking.
CHV-1-83P	Manifold mounting package (includes bolts and pipe plugs).
CHV-1-83SS-P	Stainless steel manifold mounting package (includes stainless bolts and brass plugs). Not pictured.
CHV-27-0083	Alternator bracket. Use where engine water pump is mounted on port side of engine below alternator.
CHV-47-0000	Manifold to cylinder head gasket.

Note:

Manifold includes all plugs, gaskets and mounting hardware to head. Risers include plugs, gasket and mounting hardware to manifold.

Crusader V8-283, 305, 307, 327 and 350 C.I.D.

All Models Direct Replacement

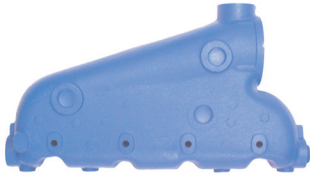

CR 1 97753

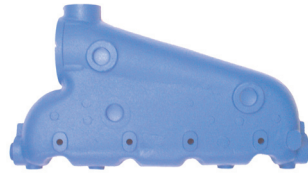

CR 1 97752



CR 20 96560

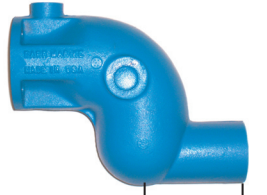

CR 20 98068

15/16" Longer



CR 20 97924



CR 20 97386



CR 20 97772



CR 20 97169



CR 20 97387



CR 20 97624



CR 20 97169P

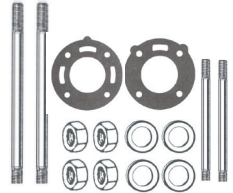

CR 20 97772P



CR 20 97296



CR 47 C 96108



CR 20 96560P

CR 50 96369

CR 50 20471

CR 50 22033

CR 50 22032



CR 47 C 96562



CHV 47 0000

CR-1-97752	Direct replacement starboard side manifold. Replaces Crusader part # 97752.
CR-1-97753	Direct replacement port side manifold. Replaces Crusader part # 97753.
CR-20-96560	Direct replacement exhaust elbow assembly, 3" I.D. exhaust hose. Replaces Crusader part # 96560.
CR-20-97169	6" riser extension. Replaces Crusader part # 97169.
CR-20-97386	90 degree swivel elbow. Replaces Crusader part # 97386.
CR-20-97387	Elbow, lower swivel with 3" outlet. Replaces Crusader part # 97387.
CR-20-97624	Elbow, lower swivel with 4" outlet. Replaces Crusader part # 97624.
CR-20-97772	4" riser extension. Replaces Crusader part # 97772.
CR-20-97924	Direct replacement exhaust elbow assembly, 4" I.D. exhaust hose. Replaces Crusader part # 97924.
CR-20-98068	Direct replacement exhaust elbow assembly, 3" I.D. exhaust hose. For use without Crusader spacer part # 97295. Replaces Crusader part # 98068.
CHV-47-0000	Manifold to cylinder head gasket.
CR-1-97752P	Manifold mounting package. Not pictured.
CR 1 97753P	Manifold mounting package (alternator side of engine). Not pictured.
CR-20-96560P	Mounting package for CR-20-96560, CR-20-97386, CR-20-97924, and CR-20-98068.
CR-20-97169P	Mounting package for CR-20-97169.
CR-20-97296	Stainless steel block off plate for fresh water applications.
CR-20-97772P	Mounting package for CR-20-97772.
CR-20-96319	143 degree thermostat for Crusader. Not pictured.
CR47-C-96108	Replacement exhaust elbow gasket (3 hole).
CR47-C-96562	Replacement exhaust elbow gasket (1 hole).
CR-50-20471	Replaces Crusader part # 20471 (3/8" X 5 3/4" stainless steel stud).
CR-50-22032	Replaces Crusader part # 22032 (3/8" X 9 3/8" stainless steel stud). For use with OEM adaptor # 97295.
CR-50-22033	Replaces Crusader part # 22033 (3/8" X 7 3/4" stainless steel stud).
CR-50-96369	Replaces Crusader part # 96369 (3/8" X 4" stainless steel stud). For use with OEM adaptor # 97295.

Note:

Manifolds and elbows include all mounting hardware, gaskets and plugs. CR-20-96169P and CR-20-97772P must be purchased separate for the corresponding risers.

Crusader V8-283, 305, 307, 327 and 350 C.I.D. Center Riser Direct Replacement



CR 1 98243

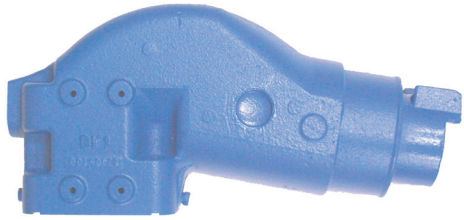

CR 20 98126

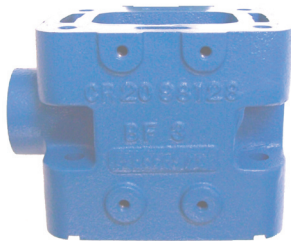

CR 20 98128

CR-1-98243	Direct replacement water cooled exhaust manifold. Replaces Crusader part # 98243.
CR-20-98126	Direct replacement water cooled center discharge riser. Replaces Crusader part # 98126. Accepts 4" I.D. exhaust hose.
CR-20-98128	Manifold to riser 3" spacer block (single). Replaces Crusader part # 98128.
CHV-47-0000	Manifold to cylinder head gasket.
CR-1-98243P	Mounting package for CR-1-98243.
CR-20-98124	Stainless steel block off plate for closed cooling applications.
CR-20-98126P	Mounting package for CR-20-98126 riser.
CR-20-98128P	Mounting package for CR-20-98128 spacer.
CR47-C-98127	Direct replacement manifold to riser gasket.

Note:
Manifold, riser and spacer block include all mounting hardware, gaskets and plugs.



CR 20 98124

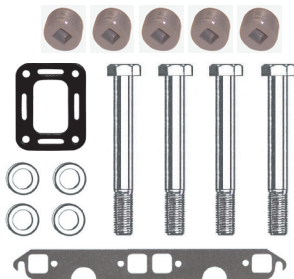

CR 1 98243P

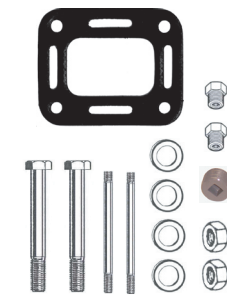

CR 20 98126P

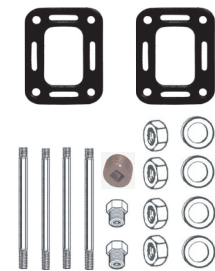

CR 20 98128P



CR47 C 98127



CHV 47 0000

Crusader V8-427 and 454 C.I.D.

All Models Center Riser Generic



CHVA 1 84

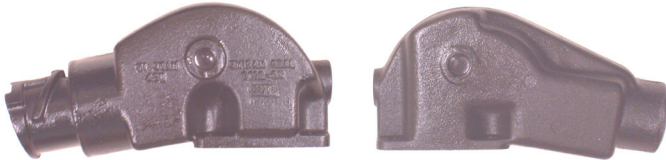

20 0100

20 0082



20 0097



20 0084P



20 0085P



20 0086P



20 0087P



20 0088P



20 0089P



20 0092P



20 0093P



20 0082P



CHVA 1 84P



1 0104P



1 0106P



1 0105



1 0107



CHVA 47 0000

CHVA-1-84	Water cooled center discharge manifold to fit the big block GM engine (3/4" N.P.T. cooling hose connections). All years.
20-0082	Water cooled center discharge riser (3/4" N.P.T. cooling hose connection). Standard for use with 3" I.D. exhaust hose.
20-0100	Water cooled center discharge riser (3/4" N.P.T. cooling hose connection). Standard for use with 4" I.D. exhaust hose.
1-0104P	Adaptor package for fresh water cooled manifold (includes gaskets and block off plate).
1-0105	Center riser manifold-to-riser gasket for fresh water cooling.
1-0106P	Adaptor package for raw water cooling. Used in pre-heating applications (includes gaskets and block off plate with vent hole).
1-0107	Center riser manifold-to-riser gasket (raw water cooling).
20-0082P	Riser mounting package for both 20-0082 and 20-0100.
20-0082SS-P	Stainless steel mounting package (with brass plugs) for both 20-0082 and 20-0100. Not pictured.
20-0084P	Straight exhaust adaptor (includes adaptor, hose and clamps). For use with 3 1/2" I.D. exhaust hose.
20-0085P	Straight exhaust adaptor (includes adaptor, hose and clamps). For use with 2 1/2" I.D. exhaust hose.
20-0086P	90 degree exhaust elbow adaptor (includes adaptor, hose and clamps). For use with 2 1/2" I.D. exhaust hose.
20-0087P	90 degree exhaust elbow adaptor (includes adaptor, hose and clamps). For use with 3" I.D. exhaust hose.
20-0088P	30 degree exhaust elbow adaptor (includes adaptor, hose and clamps). For use with 2 1/2" I.D. exhaust hose.
20-0089P	30 degree exhaust elbow adaptor (includes adaptor, hose and clamps). For use with 3" I.D. exhaust hose.
20-0092P	45 degree exhaust elbow adaptor (includes adaptor, hose and clamps). For use with 3" I.D. exhaust hose.
20-0093P	90 degree exhaust elbow adaptor (includes adaptor, hose and clamps). For use with 3 1/2" or 4" I.D. exhaust hose.
20-0097	3" spacer block (complete with mounting hardware, gasket and 3/4" pipe plug). Capable of stacking.
CHVA-1-84P	Manifold mounting package (includes bolts and pipe plugs).
CHVA-1-84SS-P	Stainless steel manifold mounting package (includes stainless bolts and brass plugs). Not pictured.
CHVA-47-0000	Manifold to cylinder head gasket.

Note:

Manifold includes all plugs, gaskets and mounting hardware to head. Risers include plugs, gasket and mounting hardware to mount to manifold.

Crusader V8- 454 and 502 C.I.D.

All Models Direct Replacement



CR 1 97993



CR 1 97992



CR 20 96560



15/16" Longer

CR 20 98068



CR 20 97924



CR 20 97386



CR 20 97387



CR 20 97772



CR 20 97169



CR 20 97624



CR 20 97169P

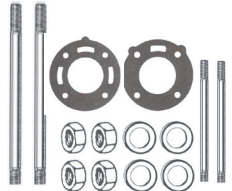

CR 20 97772P



CR47 C 96108



CR 20 97296

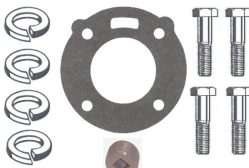

CR 20 96560P

CR 50 96369

CR 50 20471

CR 50 22033

CR 50 22032



CR47 C 96562



CHVA 47 0000

CR-1-97992	Direct replacement starboard side manifold. Replaces Crusader part # 97992.
CR-1-97993	Direct replacement port side manifold. Replaces Crusader part # 97993.
CR-20-96560	Direct replacement exhaust elbow assembly, 3" I.D. exhaust hose. Replaces Crusader part # 96560.
CR-20-97169	6" riser extension. Replaces Crusader part # 97169.
CR-20-97386	90 degree swivel elbow. Replaces Crusader part # 97386.
CR-20-97387	Elbow, lower swivel with 3" outlet. Replaces Crusader part # 97387.
CR-20-97624	Elbow, lower swivel with 4" outlet. Replaces Crusader part # 97624.
CR-20-97772	4" riser extension. Replaces Crusader part # 97772.
CR-20-97924	Direct replacement exhaust elbow assembly, 4" I.D. exhaust hose. Replaces Crusader part # 97924.
CR-20-98068	Direct replacement exhaust elbow assembly, 3" I.D. exhaust hose. For use without Crusader spacer part # 97295. Replaces Crusader part # 98068.
CHVA-47-0000	Manifold to cylinder head gasket.
CR-1-97992P	Manifold mounting package. Not pictured.
CR-1-97993P	Manifold mounting package. Not pictured.
CR-20-96560P	Mounting package for CR-20-96560, CR-20-97386, CR-20-97924, and CR-20-98068.
CR-20-97169P	Mounting package for CR-20-97169.
CR-20-97296	Stainless steel block off plate for fresh water applications.
CR-20-97772P	Mounting package for CR-20-97772.
CR-20-96319	143 degree thermostat for Crusader (not pictured).
CR47-C-96108	Replacement exhaust elbow gasket (3 hole).
CR47-C-96562	Replacement exhaust elbow gasket (1 hole).
CR-50-20471	Replaces Crusader part # 20471 (3/8" X 5 3/4" stainless steel stud).
CR-50-22032	Replaces Crusader part # 22032 (3/8" X 9 3/8" stainless steel stud). For use with OEM adaptor # 97295.
CR-50-22033	Replaces Crusader part # 22033 (3/8" X 7 3/4" stainless steel stud).
CR-50-96369	Replaces Crusader part # 96369 (3/8" X 4" stainless steel stud). For use with OEM adaptor # 97295.

Note:
Manifolds and elbows include all mounting hardware, gaskets and plugs. CR-20-96169P and CR-20-97772P must be purchased separate for the corresponding risers.

Crusader V8-302 and 351 C.I.D.

All Models Center Riser Generic

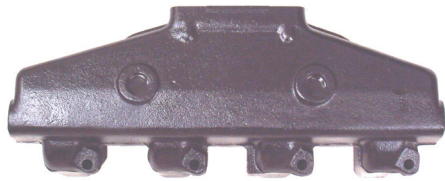

FM 1 83

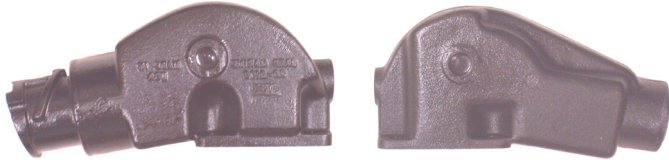

20 0100

20 0082



20 0097

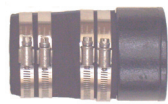

20 0084P

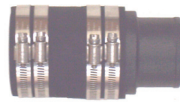

20 0085P



20 0086P



20 0087P



20 0088P



20 0089P



20 0092P



20 0093P



20 0082P



FM 1 83P



1 0104P

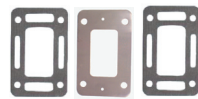

1 0106P



1 0105



1 0107



FM 47 0000

FM-1-83	Water cooled center discharge manifold to fit the small block Ford engine (3/4" N.P.T. cooling hose connections). All years.
20-0082	Water cooled center discharge riser (3/4" N.P.T. cooling hose connection). Standard for use with 3" I.D. exhaust hose.
20-0100	Water cooled center discharge riser (3/4" N.P.T. cooling hose connection). Standard for use with 4" I.D. exhaust hose.
1-0104P	Adaptor package for fresh water cooled manifold (includes gaskets and block off plate).
1-0105	Center riser manifold-to-riser gasket for fresh water cooling.
1-0106P	Adaptor package for raw water cooling. Used in pre-heating applications (includes gaskets and block off plate with vent hole).
1-0107	Center riser manifold-to-riser gasket (raw water cooling).
20-0082P	Riser mounting package for both 20-0082 and 20-0100.
20-0082SS-P	Stainless steel mounting package (with brass plugs) for both 20-0082 and 20-0100. Not pictured.
20-0084P	Straight exhaust adaptor (includes adaptor, hose and clamps). For use with 3 1/2" I.D. exhaust hose.
20-0085P	Straight exhaust adaptor (includes adaptor, hose and clamps). For use with 2 1/2" I.D. exhaust hose.
20-0086P	90 degree exhaust elbow adaptor (includes adaptor, hose and clamps). For use with 2 1/2" I.D. exhaust hose.
20-0087P	90 degree exhaust elbow adaptor (includes adaptor, hose and clamps). For use with 3" I.D. exhaust hose.
20-0088P	30 degree exhaust elbow adaptor (includes adaptor, hose and clamps). For use with 2 1/2" I.D. exhaust hose.
20-0089P	30 degree exhaust elbow adaptor (includes adaptor, hose and clamps). For use with 3" I.D. exhaust hose.
20-0092P	45 degree exhaust elbow adaptor (includes adaptor, hose and clamps). For use with 3" I.D. exhaust hose.
20-0093P	90 degree exhaust elbow adaptor (includes adaptor, hose and clamps). For use with 3 1/2" or 4" I.D. exhaust hose.
20-0097	3" spacer block (complete with mounting hardware, gasket and 3/4" pipe plug). Capable of stacking.
FM-1-83P	Manifold mounting package (includes bolts and pipe plugs).
FM-1-83SS-P	Stainless steel manifold mounting package (includes stainless bolts and brass plugs). Not pictured.
FM-47-0000	Manifold to cylinder head gasket.

Note:

Manifold includes all plugs, gaskets and mounting hardware to head. Risers include plugs, gasket and mounting hardware to mount to manifold.

Detroit Diesel 3-71, 6V-71, 4-71, 8V-71 6-71 and 12V-71

All Models Direct Replacement



DD 1 6710



DD 1 4710



DD 1 3710



DD 7 5119921

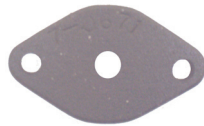

DD 7 5119924



DD 7 5119925



DD 7 5119926



1 0064



DD 47 5150195



DD 47 5150196

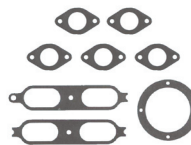

DD47 4710

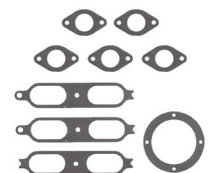

DD47 6710

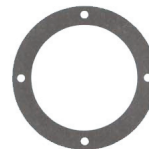

DD 47 5163811



DD 47 5156319

DD-1-3710	Direct replacement water cooled exhaust manifold to fit the 3 and 6V cylinder 71 Series Detroit Diesel.
DD-1-4710	Direct replacement water cooled exhaust manifold to fit the 4 and 8V cylinder 71 and early style 92 Series Detroit Diesel.
DD-1-6710	Direct replacement water cooled exhaust manifold to fit the 6 and 12V cylinder 71 and early style 92 Series Detroit Diesel.
1-0064	4" N.P.T. exhaust end plate. Replaces Detroit Diesel part # 5164146.
DD-7-5119921	Blank water cover plate and gasket.
DD-7-5119924	3/8" water cover plate and gasket.
DD-7-5119925	1/2" water cover plate and gasket.
DD-7-5119926	3/4" water cover plate and gasket.
DD47-4710	Exhaust manifold gasket set for 4 cylinder manifold (order (1) of the appropriate gasket set per manifold).
DD47-5150195	Exhaust manifold to head gasket for 4 and 6 cylinder manifolds (order (2) of the appropriate gaskets per manifold).
DD47-5150196	Exhaust manifold to head gasket for 6 cylinder manifold (order (1) of the appropriate gasket per manifold).
DD47-5156319	Exhaust manifold cover plate gasket for 4 and 6 cylinder manifolds (order (5) gaskets per manifold).
DD47-5163811	4" exhaust outlet gasket (order (1) gasket per manifold).
DD47-6710	Exhaust manifold gasket set for 6 cylinder manifold (order (1) gasket set per manifold).

Note:

Detroit 71 series exhaust will fit some of the earlier 92 series engines. Please call for assistance.

Barr Marine extends a 1 year warranty on these exhaust manifolds.

Flagship V8-283, 327 and 350 C.I.D.

All Models Center Riser Generic



CHV 1 83

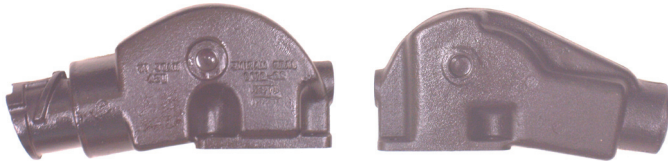

20 0100

20 0082



20 0097



20 0088P



20 0086P

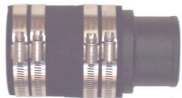

20 0085P



20 0089P



CHV 27 0083



CHV 1 83P



20 0082P



1 0104P

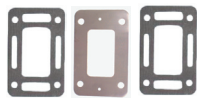

1 0106P



1 0105



1 0107



CHV 47 0000

CHV-1-83	Water cooled center discharge manifold to fit the small block GM engine (3/4" N.P.T. cooling hose connections). All years.
20-0082	Water cooled center discharge riser (3/4" N.P.T. cooling hose connection). Standard for use with 3" I.D. exhaust hose.
20-0100	Water cooled center discharge riser (3/4" N.P.T. cooling hose connection). Standard for use with 4" I.D. exhaust hose.
1-0104P	Adaptor package for fresh water cooled manifold (includes gaskets and block off plate).
1-0105	Center riser manifold-to-riser gasket for fresh water cooling.
1-0106P	Adaptor package for raw water cooling. Used in pre-heating applications (includes gaskets and block off plate with vent hole).
1-0107	Center riser manifold-to-riser gasket (raw water cooling).
20-0082P	Riser mounting package for both 20-0082 and 20-0100.
20-0082SS-P	Stainless steel mounting package (with brass plugs) for both 20-0082 and 20-0100. Not pictured.
20-0085P	Straight exhaust adaptor (includes adaptor, hose and clamps). For use with 2 1/2" I.D. exhaust hose.
20-0086P	90 degree exhaust elbow adaptor (includes adaptor, hose and clamps). For use with 2 1/2" I.D. exhaust hose.
20-0088P	30 degree exhaust elbow adaptor (includes adaptor, hose and clamps). For use with 2 1/2" I.D. exhaust hose.
20-0089P	30 degree exhaust elbow adaptor (includes adaptor, hose and clamps). For use with 3" I.D. exhaust hose.
20-0097	3" spacer block (complete with mounting hardware, gasket and 3/4" pipe plug). Capable of stacking.
CHV-1-83P	Manifold mounting package (includes bolts and pipe plugs).
CHV-1-83SS-P	Stainless steel manifold mounting package (includes stainless bolts and brass plugs). Not pictured.
CHV-27-0083	Alternator bracket. Use where engine water pump is mounted on port side of engine below alternator.
CHV-47-0000	Manifold to cylinder head gasket.

Note:

Manifold includes all plugs, gaskets and mounting hardware to head. Risers include plugs, gasket and mounting hardware to mount to manifold.

Flagship V8-283, 327 and 350 C.I.D. Log Style Generic

Starboard side part # OF 1 60R



OF 1 60L



20 0000



20 0031



20 0055



20 0039



20 0035



20 0034

OF-1-60L	Water cooled end discharge port manifold to fit the small block Chevrolet (1/2" N.P.T. cooling hose connections). All years
OF-1-60R	Water cooled end discharge starboard manifold to fit the small block Chevrolet (1/2" N.P.T. cooling hose connections). All years
1-0019	End plate gasket (will fit both ends).
20-0000	Swivel-type high discharge exhaust riser; 8 1/2" riser protection. Requires (1) mounting hardware kit #20-0002P per riser. Use only with 2 7/8" to 3" I.D. exhaust hose.
20-0002P	Mounting hardware kit.
20-0031	Swivel-type 90 degree exhaust elbow connector with internal water discharge. Accepts 2 1/2" to 3" I.D. exhaust hose. Requires (1) mounting hardware kit #20-0002P per elbow.
20-0034 or 20-0035	Exhaust connector #20-0035 (for 2 1/2" I.D. exhaust hose) or exhaust connector #20-0034 (for 3" I.D. exhaust hose). Connects to #20-0039 using (1) #20-0002P per connector.
20-0039	Fully jacketed swivel-type exhaust riser; 7" riser protection. Requires (2) mounting hardware kits #20-0002P ((1) kit to mount riser to manifold and (1) kit to mount elbows 20-0034 or 20-0035 to riser).
20-0055	Swivel-type 30 degree exhaust elbow connector; fully jacketed. Accepts 2 1/2" or 3" I.D. exhaust hose. Requires (1) mounting hardware kit #20-0002P per elbow.
CHV-47-0000	Manifold to cylinder head gasket.
OF-1-60F-P	Manifold to cylinder head mounting package.



1 0019



CHV 47 0000



20 0002P

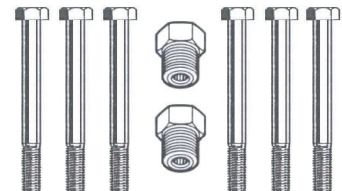

OF 1 60F P

Graymarine 4 and 6 cylinder In-Line Models

Generic

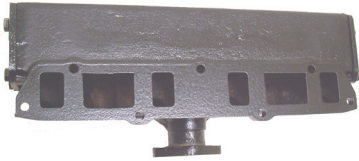

GR 1 162

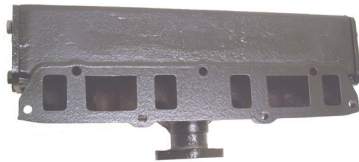

GR 1 175



GR 1 226



GR 1 0001

GR-1-162	Water cooled exhaust manifold to fit the 4-cylinder models 620, 4-60 and 70. Use with OEM risers, elbow connectors or replace with Barr products.
GR-1-175	Water cooled exhaust manifold to fit the 4-cylinder models 4-75, 4-85 and 80. Use with OEM risers, elbow connectors or replace with Barr products.
GR-1-226	Water cooled exhaust manifold to fit the 6-cylinder 226 C.I.D. models. Use with OEM riser, elbow connectors or replace with Barr products.
GR-1-0001	Exhaust end plate flange (threaded for 2" female N.P.T.).

Graymarine Fireball V8-250 and 327 C.I.D. All Models Log Style Generic

Port side part # GR 1 3274L.



GR 1 3274R



20 0000

20 0031

20 0055



20 0039



20 0035



20 0034



1 0002

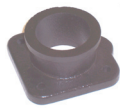

1 0069



GR 20 0001



GR 1 3274P

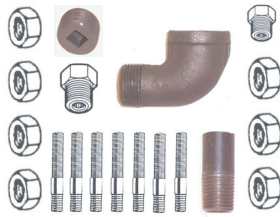

GR 1 3273P

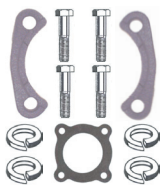

20 0002P



GR 1 0007



GR 1 0006



GR 20 0002



GR 20 0003

GR-1-3273L & R	Water cooled exhaust manifold for older 3 bolt end manifold (not pictured). Use with OEM risers and connectors or replace with Barr products.
GR-1-3274L & R	Water cooled exhaust manifold for the later 4 bolt end manifold. Use with OEM risers and connectors or replace with Barr products.
I-0002	Adaptor for 4 bolt end plate style manifold. For use with Barr style riser/elbows.
I-0069	Adaptor for 3 bolt end plate style manifold. For use with Barr style riser/elbows.
20-0000	Swivel-type high discharge exhaust riser; 8 1/2" riser protection. Requires (1) mounting hardware kit #20-0002P per riser. Use only with 2 7/8" to 3" I.D. exhaust hose.
20-0002P	Mounting hardware kit (Barr style riser/elbows only).
20-0031	Swivel-type 90 degree exhaust elbow connector with internal water discharge. Accepts 2 1/2" to 3" I.D. exhaust hose. Requires (1) mounting hardware kit #20-0002P per elbow.
20-0034 or 20-0035	Exhaust connector #20-0035 (for 2 1/2" I.D. exhaust hose) or exhaust connector #20-0034 (for 3" I.D. exhaust hose). Connects to #20-0039 using (1) #20-0002P per connector.
20-0039	Fully jacketed swivel-type exhaust riser; 7" riser protection. Requires (2) mounting hardware kits #20-0002P ((1) kit to mount riser to manifold and (1) kit to mount elbows 20-0034 or 20-0035 to riser).
20-0055	Swivel-type 30 degree exhaust elbow connector; fully jacketed. Accepts 2 1/2" or 3" I.D. exhaust hose. Requires (1) mounting hardware kit #20-0002P per elbow.
GR-1-0006	Manifold to end plate gasket.
GR-1-0007	Manifold to head gasket.
GR-20-0001	"S" turn tail pipe connector as a direct replacement of original. Requires (2) clamps # GR-20-0002 per connector. When using with 3 bolt Barr manifold, replace rear flange with end plate # GR-1-0002L and GR-1-0002R.
GR-20-0002	Mounting clamp to connect "S" turn pipe to Barr style manifold ((2) clamps required per connection).
GR-20-0003	3 or 4 bolt endplate to "S" turn tail pipe gasket.

Graymarine V8-401 C.I.D. 280 H.P.

All Models Direct Replacement

Port side part # GR-1-6470L



GR 1 6470R



20 0000



20 0031



20 0055



20 0039



20 0035



20 0034

GR-1-6470L	Water cooled exhaust manifold (port side) to fit the 401 Buick. Includes all fittings, hose adaptors and primary water pump mounting provision. Accepts Barr replacement risers and connectors only.
GR-1-6470R	Water cooled exhaust manifold (starboard side) to fit the 401 Buick. Includes all fittings, hose adaptors and primary water pump mounting provision. Accepts Barr replacement risers and connectors only.
1-0019	End plate gasket (will fit both ends).
GR-1-6470P	Manifold to cylinder head mounting kit.
20-0000	Swivel-type high discharge exhaust riser; 8 1/2" riser protection. Requires (1) mounting hardware kit #20-0002P per riser. Use only with 2 7/8" to 3" I.D. exhaust hose.
20-0002P	Mounting hardware kit (Barr style riser/elbows only).
20-0031	Swivel-type 90 degree exhaust elbow connector with internal water discharge. Accepts 2 1/2" to 3" I.D. exhaust hose. Requires (1) mounting hardware kit #20-0002P per elbow.
20-0034 or 20-0035	Exhaust connector #20-0035 (for 2 1/2" I.D. exhaust hose) or exhaust connector #20-0034 (for 3" I.D. exhaust hose). Connects to #20-0039 using (1) #20-0002P per connector.
20-0039	Fully jacketed swivel-type exhaust riser; 7" riser protection. Requires (2) mounting hardware kits #20-0002P ((1) kit to mount riser to manifold and (1) kit to mount elbows 20-0034 or 20-0035 to riser).
20-0055	Swivel-type 30 degree exhaust elbow connector; fully jacketed. Accepts 2 1/2" or 3" I.D. exhaust hose. Requires (1) mounting hardware kit #20-0002P per elbow.

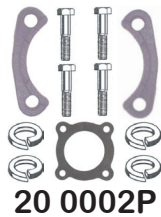

20 0002P

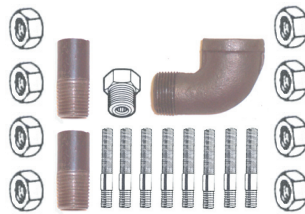

GR 1 6470P



1 0019

Indmar V8-283, 305, 307, 327 and 350 C.I.D.

All Models Inboard. Center Riser Generic



CHV 1 83

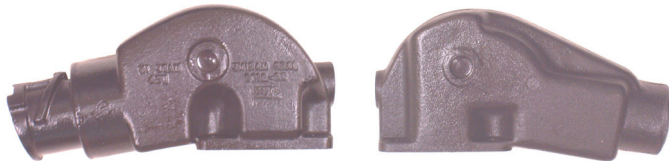

20 0100

20 0082



20 0102



20 0097



20 0088P



20 0086P



20 0085P



20 0089P



CHV 27 0083



CHV 1 83P

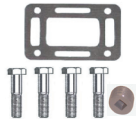

20 0082P



1 0104P



1 0106P



1 0105



1 0107



CHV 47 0000

CHV-1-83	Water cooled center discharge manifold to fit the small block GM engine (3/4" N.P.T. cooling hose connections). All years.
20-0082	Water cooled center discharge riser (3/4" N.P.T. cooling hose connection). Standard for use with 3" I.D. exhaust hose.
20-0100	Water cooled center discharge riser (3/4" N.P.T. cooling hose connection). Standard for use with 4" I.D. exhaust hose.
20-0102	Water cooled center discharge riser (3/4" N.P.T. cooling hose connection). Replaces Indmar # 532009.
1-0104P	Adaptor package for fresh water cooled manifold (includes gaskets and block off plate).
1-0105	Center riser manifold-to-riser gasket for fresh water cooling.
1-0106P	Adaptor package for raw water cooling. Used in pre-heating applications (includes gaskets and block off plate with vent hole).
1-0107	Center riser manifold-to-riser gasket (raw water cooling).
20-0082P	Riser mounting package for both 20-0082 and 20-0100.
20-0082SS-P	Stainless steel mounting package (with brass plugs) for both 20-0082 and 20-0100. Not pictured.
20-0085P	Straight exhaust adaptor (includes adaptor, hose and clamps). For use with 2 1/2" I.D. exhaust hose.
20-0086P	90 degree exhaust elbow adaptor (includes adaptor, hose and clamps). For use with 2 1/2" I.D. exhaust hose.
20-0088P	30 degree exhaust elbow adaptor (includes adaptor, hose and clamps). For use with 2 1/2" I.D. exhaust hose.
20-0089P	30 degree exhaust elbow adaptor (includes adaptor, hose and clamps). For use with 3" I.D. exhaust hose.
20-0097	3" spacer block (complete with mounting hardware, gasket and 3/4" pipe plug). Capable of stacking.
CHV-1-83P	Manifold mounting package (includes bolts and pipe plugs).
CHV-1-83SS-P	Stainless steel manifold mounting package (includes stainless bolts and brass plugs). Not pictured.
CHV-27-0083	Alternator bracket. Use where engine water pump is mounted on port side of engine below alternator.
CHV-47-0000	Manifold to cylinder head gasket.

Note:

Manifold includes all plugs, gaskets and mounting hardware to head. Risers include plugs, gasket and mounting hardware to mount to manifold.

Indmar V8-427 and 454 C.I.D. All Models Inboard Center Riser Generic



CHVA 1 84

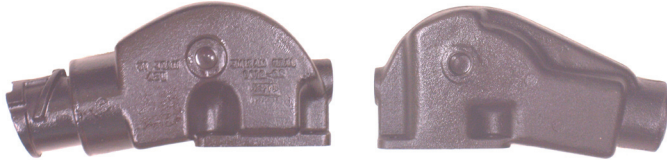

20 0100

20 0082



20 0102



20 0097



20 0084P



20 0085P



20 0086P



20 0087P



20 0088P



20 0089P



20 0092P



20 0093P



20 0082P



CHVA 1 84P



1 0104P

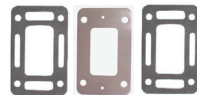

1 0106P



1 0105



1 0107



CHVA 47 0000

CHVA-1-84	Water cooled center discharge manifold to fit the big block GM engine (3/4" N.P.T. cooling hose connections). All years.
20-0082	Water cooled center discharge riser (3/4" N.P.T. cooling hose connection). Standard for use with 3" I.D. exhaust hose.
20-0100	Water cooled center discharge riser (3/4" N.P.T. cooling hose connection). Standard for use with 4" I.D. exhaust hose.
20-0102	Water cooled center discharge riser (3/4" N.P.T. cooling hose connection). Replaces Indmar # 532009.
1-0104P	Adaptor package for fresh water cooled manifold (includes gaskets and block off plate).
1-0105	Center riser manifold-to-riser gasket for fresh water cooling.
1-0106P	Adaptor package for raw water cooling. Used in pre-heating applications (includes gaskets and block off plate with vent hole).
1-0107	Center riser manifold-to-riser gasket (raw water cooling).
20-0082P	Riser mounting package for both 20-0082 and 20-0100.
20-0082SS-P	Stainless steel mounting package (with brass plugs) for both 20-0082 and 20-0100. Not pictured.
20-0084P	Straight exhaust adaptor (includes adaptor, hose and clamps). For use with 3 1/2" I.D. exhaust hose.
20-0085P	Straight exhaust adaptor (includes adaptor, hose and clamps). For use with 2 1/2" I.D. exhaust hose.
20-0086P	90 degree exhaust elbow adaptor (includes adaptor, hose and clamps). For use with 2 1/2" I.D. exhaust hose.
20-0087P	90 degree exhaust elbow adaptor (includes adaptor, hose and clamps). For use with 3" I.D. exhaust hose.
20-0088P	30 degree exhaust elbow adaptor (includes adaptor, hose and clamps). For use with 2 1/2" I.D. exhaust hose.
20-0089P	30 degree exhaust elbow adaptor (includes adaptor, hose and clamps). For use with 3" I.D. exhaust hose.
20-0092P	45 degree exhaust elbow adaptor (includes adaptor, hose and clamps). For use with 3" I.D. exhaust hose.
20-0093P	90 degree exhaust elbow adaptor (includes adaptor, hose and clamps). For use with 3 1/2" or 4" I.D. exhaust hose.
20-0097	3" spacer block (complete with mounting hardware, gasket and 3/4" pipe plug). Capable of stacking.
CHVA-1-84P	Manifold mounting package (includes bolts and pipe plugs).
CHVA-1-84SS-P	Stainless steel manifold mounting package (includes stainless bolts and brass plugs). Not pictured.
CHVA-47-0000	Manifold to cylinder head gasket.

Note:

Manifold includes all plugs, gaskets and mounting hardware to head. Risers include plugs, gasket and mounting hardware to mount to manifold.

Indmar V8-302 and 351 C.I.D. All Models Inboard Center Riser Generic

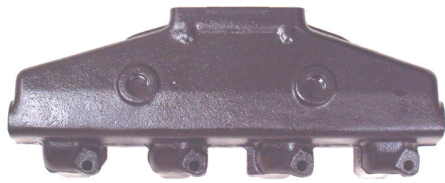

FM 1 83

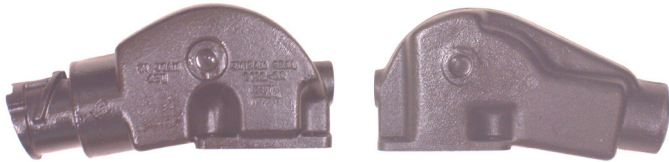

20 0100

20 0082



20 0102



20 0097



20 0084P

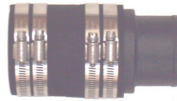

20 0085P



20 0086P



20 0087P



20 0088P



20 0089P



20 0092P



20 0093P

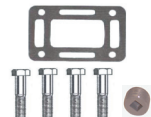

20 0082P



FM 1 83P



1 0104P



1 0106P



1 0105



1 0107



FM 47 0000

FM-1-83	Water cooled center discharge manifold to fit the small block Ford engine (3/4" N.P.T. cooling hose connections). All years.
20-0082	Water cooled center discharge riser (3/4" N.P.T. cooling hose connection). Standard for use with 3" I.D. exhaust hose.
20-0100	Water cooled center discharge riser (3/4" N.P.T. cooling hose connection). Standard for use with 4" I.D. exhaust hose.
20-0102	Water cooled center discharge riser (3/4" N.P.T. cooling hose connection). Replaces Indmar # 532009.
1-0104P	Adaptor package for fresh water cooled manifold (includes gaskets and block off plate).
1-0105	Center riser manifold-to-riser gasket for fresh water cooling.
1-0106P	Adaptor package for raw water cooling. Used in pre-heating applications (includes gaskets and block off plate with vent hole).
1-0107	Center riser manifold-to-riser gasket (raw water cooling).
20-0082P	Riser mounting package for both 20-0082 and 20-0100.
20-0082SS-P	Stainless steel mounting package (with brass plugs) for both 20-0082 and 20-0100. Not pictured.
20-0084P	Straight exhaust adaptor (includes adaptor, hose and clamps). For use with 3 1/2" I.D. exhaust hose.
20-0085P	Straight exhaust adaptor (includes adaptor, hose and clamps). For use with 2 1/2" I.D. exhaust hose.
20-0086P	90 degree exhaust elbow adaptor (includes adaptor, hose and clamps). For use with 2 1/2" I.D. exhaust hose.
20-0087P	90 degree exhaust elbow adaptor (includes adaptor, hose and clamps). For use with 3" I.D. exhaust hose.
20-0088P	30 degree exhaust elbow adaptor (includes adaptor, hose and clamps). For use with 2 1/2" I.D. exhaust hose.
20-0089P	30 degree exhaust elbow adaptor (includes adaptor, hose and clamps). For use with 3" I.D. exhaust hose.
20-0092P	45 degree exhaust elbow adaptor (includes adaptor, hose and clamps). For use with 3" I.D. exhaust hose.
20-0093P	90 degree exhaust elbow adaptor (includes adaptor, hose and clamps). For use with 3 1/2" or 4" I.D. exhaust hose.
20-0097	3" spacer block (complete with mounting hardware, gasket and 3/4" pipe plug). Capable of stacking.
FM-1-83P	Manifold mounting package (includes bolts and pipe plugs).
FM-1-83SS-P	Stainless steel manifold mounting package (includes stainless bolts and brass plugs). Not pictured.
FM-47-0000	Manifold to cylinder head gasket.

Note:

Manifold includes all plugs, gaskets and mounting hardware to head. Risers include plugs, gasket and mounting hardware to mount to manifold.

Interceptor V8-239, 256, 272, 292, and 312 C.I.D. Models 125, 135, 150, 170, 185 and 215 H.P. Log Style Generic

Port side part # INT 1 5457L

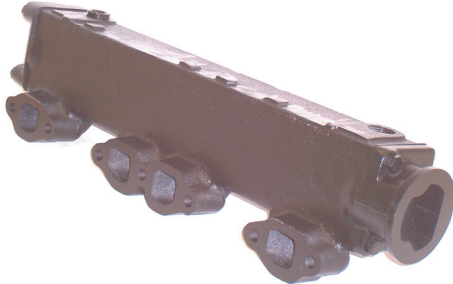

INT 1 5457R



20 0000



20 0031



20 0055



20 0039



20 0035



20 0034

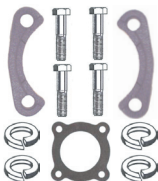

20 0002P



INT 1 5457P



1 0022

INT-1-5457L	Water cooled exhaust manifold (port side) for the Ford engine. Use with Barr risers and exhaust connectors. The original Interceptor exhaust connectors are not applicable to the Barr manifolds.
INT-1-5457R	Water cooled exhaust manifold (starboard) for the Ford engine. Use with Barr risers and exhaust connectors. The original Interceptor exhaust connectors are not applicable to the Barr manifolds.
1-0022	End plate gasket (will fit both ends).
INT-1-5457P	Manifold to cylinder head mounting kit.
20-0000	Swivel-type high discharge exhaust riser; 8 1/2" riser protection. Requires (1) mounting hardware kit #20-0002P per riser. Use only with 2 7/8" to 3" I.D. exhaust hose.
20-0002P	Mounting hardware kit (Barr style riser/elbows only).
20-0031	Swivel-type 90 degree exhaust elbow connector with internal water discharge. Accepts 2 1/2" to 3" I.D. exhaust hose. Requires (1) mounting hardware kit #20-0002P per elbow.
20-0034 or 20-0035	Exhaust connector #20-0035 (for 2 1/2" I.D. exhaust hose) or exhaust connector #20-0034 (for 3" I.D. exhaust hose). Connects to #20-0039 using (1) #20-0002P per connector.
20-0039	Fully jacketed swivel-type exhaust riser; 7" riser protection. Requires (2) mounting hardware kits #20-0002P ((1) kit to mount riser to manifold and (1) kit to mount elbows 20-0034 or 20-0035 to riser).
20-0055	Swivel-type 30 degree exhaust elbow connector; fully jacketed. Accepts 2 1/2" or 3" I.D. exhaust hose. Requires (1) mounting hardware kit #20-0002P per elbow.

Interceptor V8-352, 390 and 427 C.I.D. Models 240, 250, 260, 285, and 300 H.P. Log Style Generic

Port side part # INT 1 58L



INT 1 58R



20 0000

20 0031

20 0055



20 0039



20 0035



20 0034

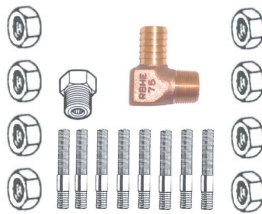

INT 1 58P

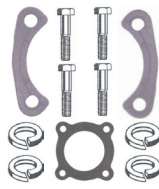

20 0002P



1 0019

INT-1-58L	Water cooled exhaust manifold (port) for the Ford engine. Use with Barr risers and connectors. The original Interceptor exhaust connectors are not applicable to the Barr manifolds.
INT-1-58R	Water cooled exhaust manifold (starboard) for the Ford engine. Use with Barr risers and connectors. The original Interceptor exhaust connectors are not applicable to the Barr manifolds.
1-0019	End plate gasket (will fit both ends).
INT-1-58P	Manifold to cylinder head mounting kit.
20-0000	Swivel-type high discharge exhaust riser; 8 1/2" riser protection. Requires (1) mounting hardware kit #20-0002P per riser. Use only with 2 7/8" to 3" I.D. exhaust hose.
20-0002P	Mounting hardware kit (Barr style riser/elbows only).
20-0031	Swivel-type 90 degree exhaust elbow connector with internal water discharge. Accepts 2 1/2" to 3" I.D. exhaust hose. Requires (1) mounting hardware kit #20-0002P per elbow.
20-0034 or 20-0035	Exhaust connector #20-0035 (for 2 1/2" I.D. exhaust hose) or exhaust connector #20-0034 (for 3" I.D. exhaust hose). Connects to #20-0039 using (1) #20-0002P per connector.
20-0039	Fully jacketed swivel-type exhaust riser; 7" riser protection. Requires (2) mounting hardware kits #20-0002P ((1) kit to mount riser to manifold and (1) kit to mount elbows 20-0034 or 20-0035 to riser).
20-0055	Swivel-type 30 degree exhaust elbow connector; fully jacketed. Accepts 2 1/2" or 3" I.D. exhaust hose. Requires (1) mounting hardware kit #20-0002P per elbow.

Interceptor V8-221, 260 and 289 C.I.D. Models 120, 140, 165, 190, 200 and 210 H.P. Log Style Generic

Port side part # INT 1 6268L



INT 1 6268R



20 0000

20 0031

20 0055



20 0039



20 0035



20 0034

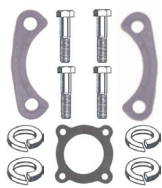

20 0002P

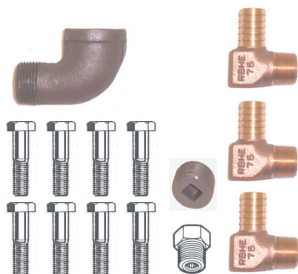

INT 1 6268P



FM 47 0000



1 0022

INT-1-6268L	Water cooled exhaust manifold (port) for the Ford engine. Use with Barr risers and connectors. The original Interceptor exhaust connectors are not applicable to the Barr manifolds.
INT-1-6268R	Water cooled exhaust manifold (starboard) for the Ford engine. Use with the Barr risers and connectors. The original Interceptor exhaust connectors are not applicable to the Barr manifolds.
1-0022	End plate gasket (will fit both ends).
INT-1-6268P	Manifold to cylinder head mounting kit.
20-0000	Swivel-type high discharge exhaust riser; 8 1/2" riser protection. Requires (1) mounting hardware kit #20-0002P per riser. Use only with 2 7/8" to 3" I.D. exhaust hose.
20-0002P	Mounting hardware kit (Barr style riser/elbows only).
20-0031	Swivel-type 90 degree exhaust elbow connector with internal water discharge. Accepts 2 1/2" to 3" I.D. exhaust hose. Requires (1) mounting hardware kit #20-0002P per elbow.
20-0034 or 20-0035	Exhaust connector #20-0035 (for 2 1/2" I.D. exhaust hose) or exhaust connector #20-0034 (for 3" I.D. exhaust hose). Connects to #20-0039 using (1) #20-0002P per connector.
20-0039	Fully jacketed swivel-type exhaust riser; 7" riser protection. Requires (2) mounting hardware kits #20-0002P ((1) kit to mount riser to manifold and (1) kit to mount elbows 20-0034 or 20-0035 to riser).
20-0055	Swivel-type 30 degree exhaust elbow connector; fully jacketed. Accepts 2 1/2" or 3" I.D. exhaust hose. Requires (1) mounting hardware kit #20-0002P per elbow.

Interceptor V8-221, 260, 289, 302 and 351 C.I.D.

All Models Center Riser Generic

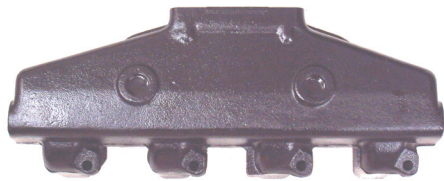

FM 1 83

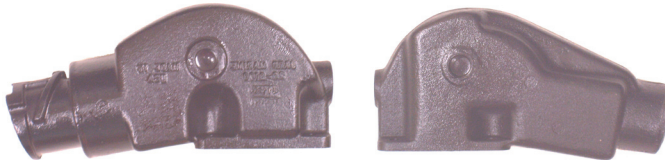

20 0100

20 0082



20 0097



20 0084P

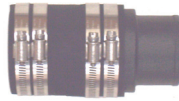

20 0085P



20 0086P



20 0087P



20 0088P



20 0089P



20 0092P



20 0093P



20 0082P



FM 1 83P



1 0104P

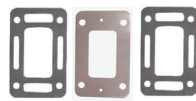

1 0106P



1 0105



1 0107



FM 47 0000

FM-1-83	Water cooled center discharge manifold to fit the small block Ford engine (3/4" N.P.T. cooling hose connections). All years.
20-0082	Water cooled center discharge riser (3/4" N.P.T. cooling hose connection). Standard for use with 3" I.D. exhaust hose.
20-0100	Water cooled center discharge riser (3/4" N.P.T. cooling hose connection). Standard for use with 4" I.D. exhaust hose.
1-0104P	Adaptor package for fresh water cooled manifold (includes gaskets and block off plate).
1-0105	Center riser manifold-to-riser gasket for fresh water cooling.
1-0106P	Adaptor package for raw water cooling. Used in pre-heating applications (includes gaskets and block off plate with vent hole).
1-0107	Center riser manifold-to-riser gasket (raw water cooling).
20-0082P	Riser mounting package for both 20-0082 and 20-0100.
20-0082SS-P	Stainless steel mounting package (with brass plugs) for both 20-0082 and 20-0100. Not pictured.
20-0084P	Straight exhaust adaptor (includes adaptor, hose and clamps). For use with 3 1/2" I.D. exhaust hose.
20-0085P	Straight exhaust adaptor (includes adaptor, hose and clamps). For use with 2 1/2" I.D. exhaust hose.
20-0086P	90 degree exhaust elbow adaptor (includes adaptor, hose and clamps). For use with 2 1/2" I.D. exhaust hose.
20-0087P	90 degree exhaust elbow adaptor (includes adaptor, hose and clamps). For use with 3" I.D. exhaust hose.
20-0088P	30 degree exhaust elbow adaptor (includes adaptor, hose and clamps). For use with 2 1/2" I.D. exhaust hose.
20-0089P	30 degree exhaust elbow adaptor (includes adaptor, hose and clamps). For use with 3" I.D. exhaust hose.
20-0092P	45 degree exhaust elbow adaptor (includes adaptor, hose and clamps). For use with 3" I.D. exhaust hose.
20-0093P	90 degree exhaust elbow adaptor (includes adaptor, hose and clamps). For use with 3 1/2" or 4" I.D. exhaust hose.
20-0097	3" spacer block (complete with mounting hardware, gasket and 3/4" pipe plug). Capable of stacking.
FM-1-83P	Manifold mounting package (includes bolts and pipe plugs).
FM-1-83SS-P	Stainless steel manifold mounting package (includes stainless bolts and brass plugs). Not pictured.
FM-47-0000	Manifold to cylinder head gasket.

Note:

Manifold includes all plugs, gaskets and mounting hardware to head. Risers include plugs, gasket and mounting hardware to mount to manifold.

MerCruiser 4 Cylinder 153 C.I.D. 120 H.P. Model 120 Engine Log Style Direct Replacement

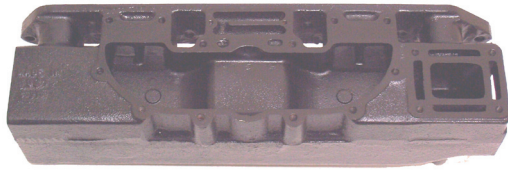

MC 1 63122



MC 20 55538



MC 29 60372



MC 29 47587



1 73811



1 47638



MC47 475KIT



MC47 27 35898

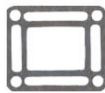

MC47 27 39915

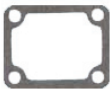

1 73811P

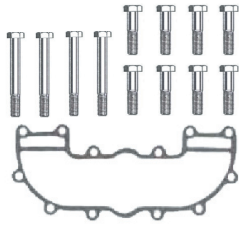

MC 1 35898P

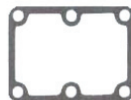

1 47638P

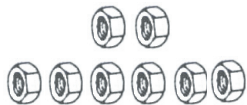

MC 1 63122P

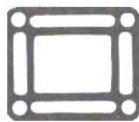

MC 20 55538P

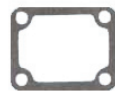

MC47 27 39923

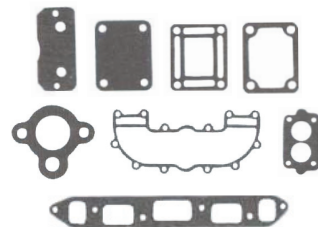

MC47 27 35898A4

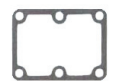

MC47 27 39917



MC47 27 52546

MC-1-63122	Direct replacement water cooled exhaust manifold. Replaces MerCruiser part # B-63122A1.
MC-20-55538	Direct replacement exhaust elbow/riser. Replaces MerCruiser part # B-39920 and # B-55538A2.
MC-20-55538P	Riser to exhaust manifold mounting package.
1-39949P	Choke oven cover assembly. Not pictured.
1-47638	Direct replacement exhaust manifold end cap/connector (front). Replaces MerCruiser part # B-47638.
1-47638P	Exhaust manifold end cap/connector (front) mounting package.
1-73811	Direct replacement exhaust manifold end cap (rear).
1-73811P	Exhaust manifold end cap (rear) mounting package.
MC-1-35898P	Intake manifold mounting package.
MC-1-63122P	Exhaust manifold mounting package.
MC-29-47587	Direct replacement lower thermostat housing.
MC-29-60372	Direct replacement upper thermostat housing.
MC47-475KIT	Thermostat kit (includes gasket and thermostat).
MC47-27-35898	Direct replacement intake manifold gasket.
MC47-27-35898A4	Exhaust manifold gasket set.
MC47-27-39915	Direct replacement exhaust manifold to exhaust elbow gasket.
MC47-27-39917	Direct replacement exhaust manifold end cap/connector gasket.
MC47-27-39923	Direct replacement exhaust manifold end cap gasket.
MC47-27-52546	Direct replacement exhaust manifold to cylinder head gasket.

Note:

Manifold includes all plugs, gaskets and mounting hardware to head. Riser includes plugs, gasket and mounting hardware to mount to manifold.

MerCruiser 4 Cylinder 181 C.I.D. 140 H.P. Model 140 Engine Log Style Direct Replacement



MC 1 52390

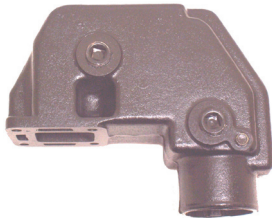

MC 20 60426



MC 20 61851A3



MC 29 47587



MC 29 60372



MC47 475KIT



MC 20 60426P



1 54870/73813

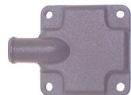

1 60252



1 60252P



1 54870P

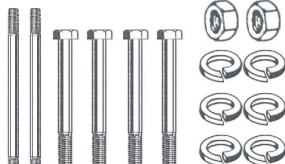

MC 1 52390P



MC 20 60207



MC 20 55730

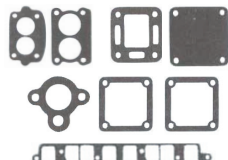

MC47 27 53354A1



MC47 27 73814



MC47 27 52076



MC47 27 48043



MC47 27 53354

MC-1-52390	Direct replacement water cooled exhaust manifold. Replaces MerCruiser part # B-52390A1. For serial # 3332138 and up.
MC-20-60426	Direct replacement exhaust elbow riser (utilizes a stainless steel sleeve at the water/air mixing area). Replaces MerCruiser part #B-60426A1.
MC-20-76351	Direct replacement exhaust elbow riser. Replaces MerCruiser part # B-76351A1. Not pictured.
1-54870	Direct replacement exhaust manifold rear end cap. Serial # 4481625 and below.
1-54870P	Rear end cap mounting package.
1-60252	Direct replacement exhaust manifold end cap/connector. Replaces MerCruiser part # B-60252.
1-60252P	Front end plate mounting package.
1-73813	Direct replacement exhaust manifold rear end cap. Serial # 4481625 and up.
MC-1-52390P	Exhaust manifold mounting package.
MC-20-55730	Stainless steel fresh water cooling block off plate for use with MerCruiser riser #'s 60426, 76351 and 76771. Requires (2) gaskets part # MC47-27-52076.
MC-20-60207	Stainless steel block off plate (with vent hole) for use with MerCruiser riser #'s 60426, 76351 and 76771. Requires (2) gaskets part # MC47-27-52076. Used in pre-heating plumbing systems.
MC-20-60426P	Exhaust riser elbow mounting package. For use with both MC-20-60426 and MC-20-76351 risers.
MC-20-61851A3	Manifold to riser 3" spacer (single block). Includes all mounting hardware, gaskets and drain plug.
MC-29-47587	Lower thermostat housing.
MC-29-60372	Upper thermostat housing.
MC47-475KIT	Thermostat kit (includes gasket and thermostat).
MC47-27-48043	Direct replacement exhaust manifold end cap/connector gasket (will fit both ends).
MC47-27-52076	Direct replacement exhaust elbow to exhaust manifold gasket.
MC47-27-53354	Direct replacement exhaust manifold to cylinder head gasket.
MC47-27-53354A1	Exhaust manifold gasket set.
MC47-27-73814	Direct replacement exhaust manifold end cap gasket. Utilized with 1-73813 rear end cap.

Note:
Manifold includes all plugs, gaskets and mounting hardware to head. Riser includes plugs, gasket and mounting hardware to mount to manifold.

MerCruiser 4 Cylinder 153 C.I.D. and 181 C.I.D. 120 H.P. (2.5L), 140 H.P. (3.0L) Models 120R and 140R-MR/Alpha 1 Engines Log Style Direct Replacement



MC 1 99798



MC 20 12076



MC 20 76325



MC 20 61851A3



MC 29 47587



MC 29 60372



MC47 475KIT



MC 20 12076P



1 99179

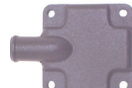

1 60252

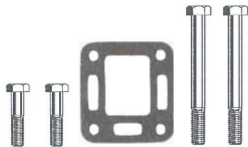

MC 20 76325P

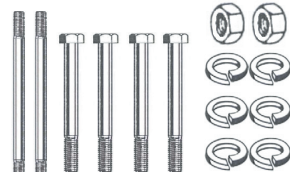

MC 1 99798P



MC47 27 48043

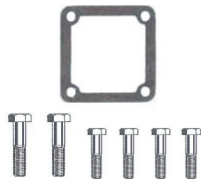

1 60252P



1 99179P



MC47 27 73814

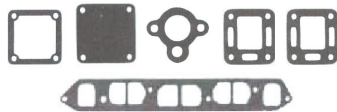

MC47 27 99777A1



MC47 27 96429



MC47 27 99777

MC-1-95862	Direct replacement water cooled manifold (Rochester (3 1/4" X 1 7/8") bolt pattern). 6 bolt mounting. Replaces MerCruiser part # 95862A9 (no choke stove).
MC-1-96705	Direct replacement water cooled manifold (Rochester (3 1/4" X 1 7/8") bolt pattern). 6 bolt mounting. Replaces MerCruiser part # 96705A1.
MC-1-99798	Direct replacement water cooled manifold (MerCarb (3 11/16" X 2") bolt pattern). 6 bolt mounting. Replaces MerCruiser part # 99798A9.
MC-20-12076	Direct replacement exhaust riser. Replaces MerCruiser part # 12076A2.
MC-20-76325	Direct replacement exhaust riser. Replaces MerCruiser part # 76325A2.
1-60252	Direct replacement exhaust manifold end cap/connector. Replaces MerCruiser part # B-60252.
1-60252P	Front end plate mounting package.
1-99197	Direct replacement exhaust manifold rear end cap/lifting eye.
1-99179P	Rear end cap mounting package.
MC-1-99798P	Exhaust manifold to cylinder head mounting package.
MC-20-61851A3	Manifold to riser 3" spacer (single block). Includes all mounting hardware, gaskets and drain plug.
MC-29-47587	Lower thermostat housing.
MC-29-60372	Upper thermostat housing.
MC47-475KIT	Thermostat kit (includes gasket and thermostat).
MC47-27-48043	Direct replacement exhaust manifold end cap/connector gasket (will fit both ends).
MC47-27-73814	Direct replacement exhaust manifold end cap gasket. Utilized with 1-73813 rear end cap.
MC47-27-96429	Direct replacement exhaust manifold to cylinder head gasket.
MC47-27-99777	Direct replacement exhaust elbow to manifold gasket. Supersedes MerCruiser part # 27-52076.
MC47-27-99777A1	Exhaust manifold gasket set.

Note:
Manifold includes all plugs, gaskets and mounting hardware to head. Risers include plugs, gasket and mounting hardware to mount to manifold.

MerCruiser Straight 6 Cylinder Model 165

Log Style Direct Replacement



MC 1 58759

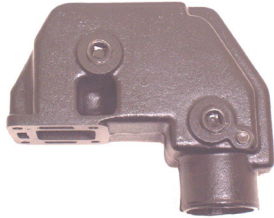

MC 20 60426



MC 20 61851A3



MC 29 47587



MC 29 60372



MC47 475KIT



MC 20 60426P



1 54870/73813



1 60252

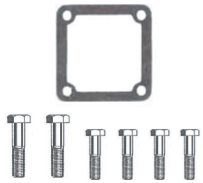

1 60252P

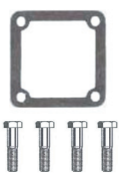

1 54870P

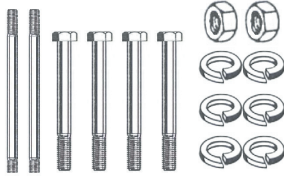

MC 1 58759P

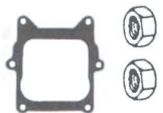

MC 20 60207



MC 20 55730



MC 1 58764P



MC47 27 46401

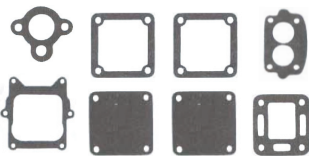

MC47 27 46401A1



MC47 27 58764



MC47 27 99777



MC47 27 73814



MC47 27 48043

MC-1-58759	Direct replacement water cooled manifold to fit the 6 cyl. GM (Model 165) engine. Replaces MerCruiser part # B-58759A1.
MC-20-60426	Direct replacement exhaust elbow riser (utilizes a stainless steel sleeve at the water/air mixing area). Replaces MerCruiser part #B-60426A1.
MC-20-76351	Direct replacement exhaust elbow riser. Replaces MerCruiser part # B-76351A1. Not pictured.
1-54870	Direct replacement exhaust manifold end cap (rear). Superseded by part # 1-73813.
1-54870P	Exhaust manifold end cap (rear) mounting package.
1-60252	Direct replacement exhaust manifold end cap/connector (front). Replaces MerCruiser part # B-60252.
1-60252P	Exhaust manifold end cap/connector mounting package.
1-73813	Direct replacement manifold end cap (rear). Supercedes part # 1-54870.
1-71813P	Exhaust manifold end cap mounting package.
MC-1-58759P	Exhaust manifold mounting package.
MC-1-58764P	Manifold to carburetor adaptor mounting package.
MC-20-55730	Stainless steel fresh water cooling block off plate for use with MerCruiser riser #'s 60426, 76351 and 76771. Requires (2) gaskets part # MC47-27-99777.
MC-20-60207	Stainless steel block off plate (with vent hole) for use with MerCruiser riser #'s 60426, 76351 and 76771. Requires (2) gaskets part # MC47-27-99777. Used in pre-heating plumbing systems.
MC-20-60426P	Exhaust riser elbow mounting package. For use with both MC-20-60426 and MC-20-76351 risers.
MC-20-61851A3	Manifold to riser 3" spacer (single block). Includes all mounting hardware, gaskets and drain plug.
MC-29-47587	Lower thermostat housing.
MC-29-60372	Upper thermostat housing.
MC47-475KIT	Thermostat kit (includes gasket and thermostat).
MC47-27-46401	Direct replacement manifold to head gasket.
MC47-27-46401A1	Exhaust manifold gasket set.
MC47-27-48043	Direct replacement exhaust manifold end cap/connector gasket (will fit both ends).
MC47-27-58764	Direct replacement manifold to carburetor adaptor gasket.
MC47-27-73814	Direct replacement exhaust manifold end cap gasket. Utilized with 1-73814 rear end cap.
MC47-27-99777	Direct replacement exhaust elbow to manifold gasket. Supersedes MerCruiser part # 27-52076.

Note:

Manifold includes all plugs, gaskets and mounting hardware to head. Risers include plugs, gasket and mounting hardware to mount to manifold.

MerCruiser V6-229 C.I.D and 262 C.I.D.

Models 185R, 185MR, 205R and 205MR

Center Riser Direct Replacement



MC 1 99746

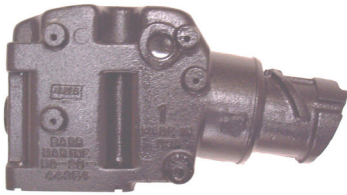

MC 20 44354

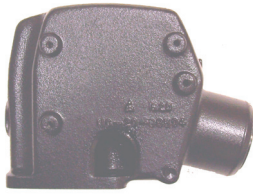

MC 20 98504



MC 20 93322A3



MC 20 93320A3



MC 27 93175



MC 20 87918



MC 20 99208



MC 50 806926

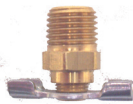

MC 50 87238



MC 20 44354P

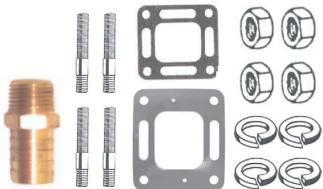

MC 20 98504P



MC47 27 41811



MC47 27 87105



MC47 27 41813



MC47 27 99757

MC-1-99746	Direct replacement water cooled exhaust manifold. Replaces MerCruiser part # 99746A3 or part # 99746A8.
MC-20-44354	Direct replacement water cooled center discharge riser. Replaces MerCruiser part # B-44354A3. Accepts 4" I.D. exhaust hose (8 degree angle).
MC-20-98504	Direct replacement water cooled center discharge riser. Replaces MerCruiser part #98504A3. Accepts 3" I.D. exhaust hose (15 degree angle).
MC-20-44354P	Mounting package for MC-20-44354 riser.
MC-20-87918	Direct replacement stainless steel block off plate for use with MerCruiser riser #'s 98502, 98504 and 44354. Requires (2) gaskets part # MC47-27-41813.
MC-20-93320A3	Manifold to riser 3" spacer blocks (pair) with fastener and gasket package.
MC-20-93322A3	Manifold to riser 6" spacer blocks (pair) with fastener and gasket package.
MC-20-98504P	Mounting package for MC-20-98504 riser (includes gaskets, drain plug, pipe plug, stainless steel restrictor plate and fasteners).
MC-20-99208	Direct replacement stainless steel restrictor plate for use with MerCruiser riser #'s 98502, 98504 and 44354. Requires (2) gaskets part # MC47-27-41813.
MC-27-93175	Alternator bracket.
MC47-27-41811	Direct replacement restrictor gasket. Replaces MerCruiser part # 27-41811. To be used with MC-20-87918 ((2) required per plate used).
MC47-27-41813	Direct replacement restrictor gasket. Replaces MerCruiser part # 41813.
MC47-27-87105	Direct replacement exhaust elbow gasket. Replaces MerCruiser part # 27-87105.
MC47-27-99757	Direct replacement manifold to head gasket.
MC-50-87238	Exhaust manifold drain cock.
MC-50-806926	Replacement 3/4" N.P.T. X 1" hose fitting (90 degree)/brass drain cock.

Note:

Manifold includes all plugs, gaskets and mounting hardware to head. Risers include plugs, gasket and mounting hardware to mount to manifold.

MerCruiser V8-283, 302, 305, 307, 327 and 350 C.I.D. All Models Center Riser Generic



CHV 1 83

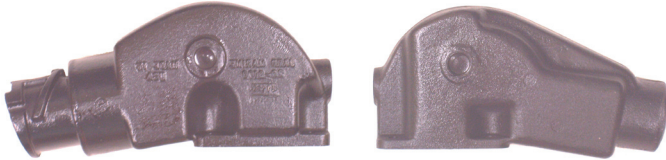

20 0100

20 0082



20 0097



20 0084P

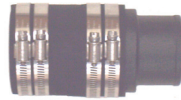

20 0085P



20 0086P



20 0087P



20 0088P



20 0089P



20 0092P



20 0093P



CHV 27 0083

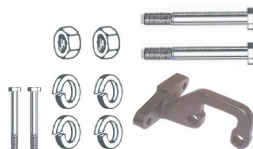

MC 45 0002



CHV 1 83P

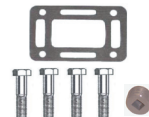

20 0082P

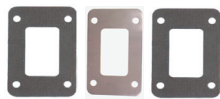

1 0104P

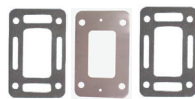

1 0106P



1 0105



1 0107



CHV 47 0000

CHV-1-83	Water cooled center discharge manifold to fit the small block GM engine (3/4" N.P.T. cooling hose connections). All years.
20-0082	Water cooled center discharge riser (3/4" N.P.T. cooling hose connection). Standard for use with 3" I.D. exhaust hose.
20-0100	Water cooled center discharge riser (3/4" N.P.T. cooling hose connection). Standard for use with 4" I.D. exhaust hose.
1-0104P	Adaptor package for fresh water cooled manifold (includes gaskets and block off plate).
1-0105	Center riser manifold-to-riser gasket for fresh water cooling.
1-0106P	Adaptor package for raw water cooling. Used in pre-heating applications (includes gaskets and block off plate with vent hole).
1-0107	Center riser manifold-to-riser gasket (raw water cooling).
20-0082P	Riser mounting package for both 20-0082 and 20-0100.
20-0082SS-P	Stainless steel mounting package (with brass plugs) for both 20-0082 and 20-0100. Not pictured.
20-0084P	Straight exhaust adaptor (includes adaptor, hose and clamps). For use with 3 1/2" I.D. exhaust hose.
20-0085P	Straight exhaust adaptor (includes adaptor, hose and clamps). For use with 2 1/2" I.D. exhaust hose.
20-0086P	90 degree exhaust elbow adaptor for I/O applications (includes adaptor, hose and clamps). For use with 2 1/2" I.D. exhaust hose.
20-0087P	90 degree exhaust elbow adaptor (includes adaptor, hose and clamps). For use with 3" I.D. exhaust hose.
20-0088P	30 degree exhaust elbow adaptor (includes adaptor, hose and clamps). For use with 2 1/2" I.D. exhaust hose.
20-0089P	30 degree exhaust elbow adaptor (includes adaptor, hose and clamps). For use with 3" I.D. exhaust hose.
20-0092P	45 degree exhaust elbow adaptor (includes adaptor, hose and clamps). For use with 3" I.D. exhaust hose.
20-0093P	90 degree exhaust elbow adaptor (includes adaptor, hose and clamps). For use with 3 1/2" or 4" I.D. exhaust hose.
20-0097	3" spacer block (complete with mounting hardware, gasket and 3/4" pipe plug). Capable of stacking.
CHV-1-83P	Manifold mounting package (includes bolts and pipe plugs).
CHV-1-83SS-P	Stainless steel manifold mounting package (includes stainless bolts and brass plugs). Not pictured.
CHV-27-0083	Alternator bracket. Use where engine water pump is mounted on port side of engine below alternator.
MC-45-0002	Fuel filter/solenoid bracket.
CHV-47-0000	Manifold to cylinder head gasket.

Note:

Manifold includes all plugs, gaskets and mounting hardware to head. Risers include plugs, gasket and mounting hardware to mount to manifold.

MerCruiser V8-198, 228, 255, 260 and 898

Inboard and Stern-Drive Units

Log Style Direct Replacement



MC 1 77234



MC 1 77235

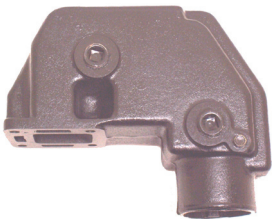

MC 20 60426

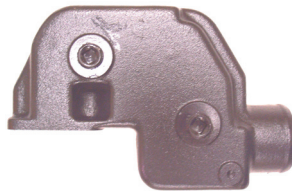

MC 20 76771

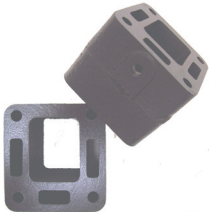

MC 20 61851A2



MC 29 78984



MC 29 47441

MC 27 48104



1 73813

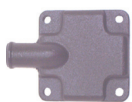

1 60252



MC47 488KIT



MC 20 60207



MC 20 55730



MC 20 60426P

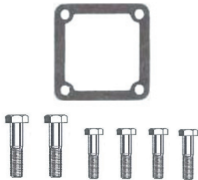

1 60252P

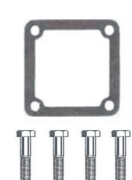

1 73813P



MC 1 77234P

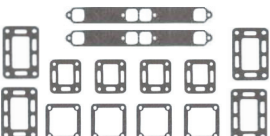

MC47 27 33395A2



MC47 27 99777



MC47 27 48043



MC47 27 33395

MC-1-77234	Direct replacement water cooled exhaust manifold (port side). Replaces MerCruiser part # B-77234A2.
MC-1-77235	Direct replacement water cooled exhaust manifold (starboard side). Replaces MerCruiser part # B-77235A2.
MC-20-60426	Direct replacement exhaust elbow riser (utilizes a stainless steel sleeve at the water/air mixing area). Replaces MerCruiser part #B-60426A1 (I/O applications).
MC-20-76351	Direct replacement exhaust elbow riser. Replaces MerCruiser part # B-76351A1 (I/O applications). Not pictured.
MC-20-76771	Direct replacement exhaust elbow riser. Replaces MerCruiser part # B-76771A3 (inboard applications).
1-60252	Direct replacement exhaust manifold end cap/connector. Replaces MerCruiser part # B-60252.
1-60252P	Front end plate mounting package.
1-73813	Direct replacement manifold end cap (rear). Supersedes part # 1-54870.
1-73813P	Rear end cap mounting package.
MC-1-77234P	Manifold mounting package.
MC-20-55730	Stainless steel fresh water cooling block off plate for use with MerCruiser riser #'s 60426, 76351 and 76771. Requires (2) gaskets part # MC47-27-99777.
MC-20-60207	Stainless steel block off plate (with vent hole) for use with MerCruiser riser #'s 60426, 76351 and 76771. Requires (2) gaskets part # MC47-27-99777. Used in pre-heating plumbing systems.
MC-20-60426P	Exhaust riser elbow mounting package. For use with both MC-20-60426 and MC-20-76351 risers.
MC-20-61851A2	Manifold to riser 3" spacers (sold in pairs). Includes all mounting hardware, gaskets and drain plugs.
MC-27-48104	Alternator mounting bracket.
MC-29-47441	Upper thermostat housing.
MC-29-78984	Lower thermostat housing.
MC47-488KIT	Thermostat kit (includes gasket and thermostat).
MC47-27-33395	Direct replacement exhaust manifold to head gasket.
MC47-27-33395A2	Exhaust manifold gasket set.
MC47-27-48043	Direct replacement exhaust manifold end cap/connector gasket (will fit both ends).
MC47-27-99777	Direct replacement exhaust elbow to manifold gasket. Supersedes MerCruiser part # 27-52076.

Note:

Manifold includes all plugs, gaskets and mounting hardware to head. Riser includes plugs, gasket and mounting hardware to mount to manifold.

MerCruiser V8 Models 898R, 228R and 260R

Center Riser Direct Replacement



MC 1 87114

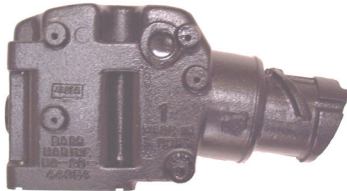

MC 20 44354

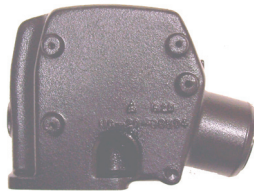

MC 20 98504

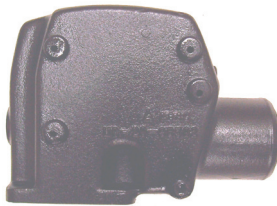

MC 20 98502



MC 20 93320A3

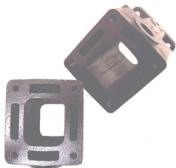

MC 20 93322A3



MC 29 47441



MC 29 87290



MC 27 93175



MC 20 87918



MC 20 99208



MC 50 806926



MC 50 87238

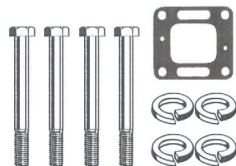

MC 20 44354P

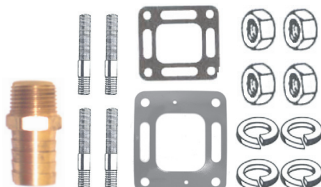

MC 20 98504P



MC47 27 41811



MC47 27 87105



MC47 27 41813



MC47 27 33395

MC-1-87114	Direct replacement water cooled exhaust manifold. Replaces MerCruiser part # 87114A8, 87114A19 and #860246A10.
MC-20-44354	Direct replacement water cooled center discharge riser. Replaces MerCruiser part # B-44354A3. Accepts 4" I.D. exhaust hose (8 degree angle).
MC-20-98502	Direct replacement water cooled center discharge riser. Replaces MerCruiser part #98502A2. Accepts 3" I.D. exhaust hose (0 degree angle).
MC-20-98504	Direct replacement water cooled center discharge riser. Replaces MerCruiser part #98504A3. Accepts 3" I.D. exhaust hose (15 degree angle).
MC-20-44354P	Mounting package for MC-20-44354 riser.
MC-20-87918	Direct replacement stainless steel block off plate for use with MerCruiser riser #'s 98502, 98504 and 44354. Requires (2) gaskets part # MC47-27-41813.
MC-20-93320A3	Manifold to riser 3" spacer blocks (pair) with fastener and gasket package.
MC-20-93322A3	Manifold to riser 6" spacer blocks (pair) with fastener and gasket package.
MC-20-98504P	Mounting package for MC-20-98504 riser (includes gaskets, drain plug, pipe plug, stainless steel restrictor plate and fasteners).
MC-20-99208	Direct replacement stainless steel restrictor plate for use with MerCruiser riser #'s 98502, 98504 and 44354. Requires (2) gaskets part # MC47-27-41813.
MC-27-93175	Alternator bracket.
MC-29-47441	Upper thermostat housing.
MC-29-87290	Lower thermostat housing.
MC47-27-33395	Direct replacement exhaust manifold to head gasket.
MC47-27-41811	Direct replacement restrictor gasket. Replaces MerCruiser part # 27-41811. To be used with MC-20-87918 ((2) required per plate used).
MC47-27-41813	Direct replacement restrictor gasket. Replaces MerCruiser part # 27-41813.
MC47-27-87105	Direct replacement exhaust elbow gasket. Replaces MerCruiser part # 27-87105.
MC-50-87238	Exhaust manifold drain cock.
MC-50-806926	Replacement 3/4" N.P.T. X 1" hose fitting (90 degree)/brass drain cock.

Note:

Manifold includes all plugs, gaskets and mounting hardware to head. Risers include plugs, gasket and mounting hardware to mount to manifold.

MerCruiser V8-225, 250, 255, 270 and 280

Inboard and Stern-Drive Units

Log Style Direct Replacement



MC 1 47737



MC 1 47738



MC 20 72963

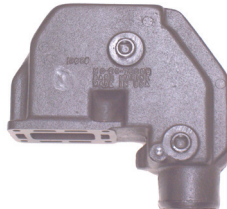

MC 20 76668



MC 20 61811A4



MC 29 78984



MC 29 47441



1 73813

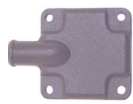

1 60252



MC47 488KIT



MC 20 76668P



MC 20 72963P

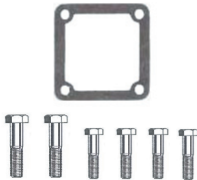

1 60252P

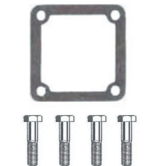

1 73813P

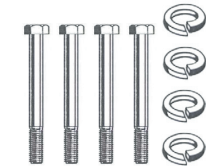

MC 1 77234P

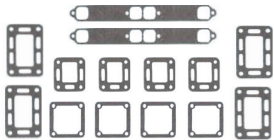

MC47 27 33395A2



MC47 27 48042



MC47 27 48043



MC47 27 33395

MC-1-47737	Direct replacement water cooled exhaust manifold (port side). Replaces MerCruiser part # B-47737A1.
MC-1-47738	Direct replacement water cooled exhaust manifold (starboard side). Replaces MerCruiser part # B-47738A1.
MC-20-72963	Direct replacement exhaust elbow riser. Replaces MerCruiser part # B-72963A1 (inboard applications).
MC-20-76668	Direct replacement exhaust elbow riser. Replaces MerCruiser part # B-76668A3, B-72964A1 and B-47877A4 (I/O applications).
1-60252	Direct replacement exhaust manifold end cap/connector. Replaces MerCruiser part # B-60252.
1-60252P	Front end plate mounting package.
1-73813	Direct replacement manifold end cap (rear). Supercedes part # 1-54870.
1-73813P	Rear end cap mounting package.
MC-1-77234P	Manifold mounting package. Use this package for the MC-1-47737 and MC-1-47738 manifolds.
MC-20-72963P	Exhaust riser elbow mounting package.
MC-20-76668P	Exhaust riser elbow mounting package.
MC-20-61811A4	Manifold to riser 3" spacers (sold in pairs). Includes all mounting hardware, gaskets and drain plugs.
MC-29-47441	Upper thermostat housing.
MC-29-78984	Lower thermostat housing.
MC47-488KIT	Thermostat kit (includes gasket and thermostat).
MC47-27-33395	Direct replacement exhaust manifold to head gasket.
MC47-27-33395A2	Exhaust manifold gasket set.
MC47-27-48042	Direct replacement exhaust elbow to manifold gasket.
MC47-27-48043	Direct replacement exhaust manifold end cap/connector gasket (will fit both ends).

Note:
Manifold includes all plugs, gaskets and mounting hardware to head. Riser includes plugs, gasket and mounting hardware to mount to manifold.

MerCruiser V8-454 and 502 C.I.D.

All Models Center Riser Generic



CHVA 1 84

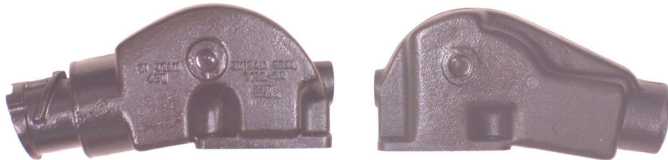

20 0100

20 0082



20 0097

20 0084P

20 0085P



20 0086P

20 0087P

20 0088P



20 0089P

20 0092P

20 0093P



MC 27 47487

20 0082P

CHVA 1 84P



1 0104P

1 0106P



1 0105

1 0107

CHVA 47 0000

CHVA-1-84	Water cooled center discharge manifold to fit the big block GM engine (3/4" N.P.T. cooling hose connections). All years.
20-0082	Water cooled center discharge riser (3/4" N.P.T. cooling hose connection). Standard for use with 3" I.D. exhaust hose.
20-0100	Water cooled center discharge riser (3/4" N.P.T. cooling hose connection). Standard for use with 4" I.D. exhaust hose.
1-0104P	Adaptor package for fresh water cooled manifold (includes gaskets and block off plate).
1-0105	Center riser manifold-to-riser gasket for fresh water cooling.
1-0106P	Adaptor package for raw water cooling. Used in pre-heating applications (includes gaskets and block off plate with vent hole).
1-0107	Center riser manifold-to-riser gasket (raw water cooling).
20-0082P	Riser mounting package for both 20-0082 and 20-0100.
20-0082SS-P	Stainless steel mounting package (with brass plugs) for both 20-0082 and 20-0100. Not pictured.
20-0084P	Straight exhaust adaptor (includes adaptor, hose and clamps). For use with 3 1/2" I.D. exhaust hose.
20-0085P	Straight exhaust adaptor (includes adaptor, hose and clamps). For use with 2 1/2" I.D. exhaust hose.
20-0086P	90 degree exhaust elbow adaptor for I/O applications (includes adaptor, hose and clamps). For use with 2 1/2" I.D. exhaust hose.
20-0087P	90 degree exhaust elbow adaptor (includes adaptor, hose and clamps). For use with 3" I.D. exhaust hose.
20-0088P	30 degree exhaust elbow adaptor (includes adaptor, hose and clamps). For use with 2 1/2" I.D. exhaust hose.
20-0089P	30 degree exhaust elbow adaptor (includes adaptor, hose and clamps). For use with 3" I.D. exhaust hose.
20-0092P	45 degree exhaust elbow adaptor (includes adaptor, hose and clamps). For use with 3" I.D. exhaust hose.
20-0093P	90 degree exhaust elbow adaptor (includes adaptor, hose and clamps). For use with 3 1/2" or 4" I.D. exhaust hose.
20-0097	3" spacer block (complete with mounting hardware, gasket and 3/4" pipe plug). Capable of stacking.
CHVA-1-84P	Manifold mounting package (includes bolts and pipe plugs).
CHVA-1-84SS-P	Stainless steel manifold mounting package (includes stainless bolts and brass plugs). Not pictured.
CHVA-47-0000	Manifold to cylinder head gasket.
MC-27-47487	Alternator bracket.

Note:

Manifold includes all plugs, gaskets and mounting hardware to head. Risers include plugs, gasket and mounting hardware to mount to manifold.

MerCruiser V8-325, 330, 350, 370 and 400

Inboard and Stern-Drive Units

Log Style Direct Replacement



MC 1 47735



MC 1 47736

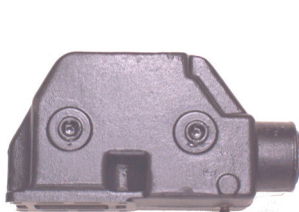

MC 20 72963

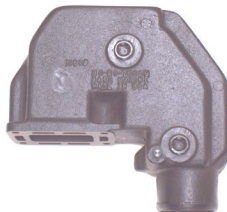

MC 20 76668



MC 20 61811A4



MC 29 78985



MC 29 47441



MC 27 47487



MC47 488KIT



1 73813

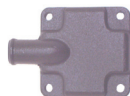

1 60252



MC 20 76668P



MC 20 72963P

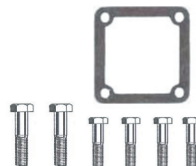

1 60252P

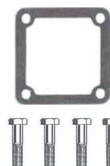

1 73813P

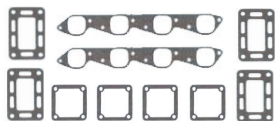

MC47 27 46820A1



MC47 27 48042



MC47 27 48043



MC47 27 46820

MC-1-47735	Direct replacement water cooled exhaust manifold (port side). Replaces MerCruiser part # B-47735A1.
MC-1-47736	Direct replacement water cooled exhaust manifold (starboard side). Replaces MerCruiser part # B-47736A1.
MC-20-72963	Direct replacement exhaust elbow riser. Replaces MerCruiser part # B-72963A1 (inboard applications).
MC-20-76668	Direct replacement exhaust elbow riser. Replaces MerCruiser part # B-76668A3, B-72964A1 and B-47877A4 (I/O applications).
1-60252	Direct replacement exhaust manifold end cap/connector. Replaces MerCruiser part # B-60252.
1-60252P	Front end plate mounting package.
1-73813	Direct replacement manifold end cap (rear). Supercedes part # 1-54870.
1-73813P	Rear end cap mounting package.
MC-20-72963P	Exhaust riser elbow mounting package.
MC-20-76668P	Exhaust riser elbow mounting package.
MC-20-61811A4	Manifold to riser 3" spacers (sold in pairs). Includes all mounting hardware, gaskets and drain plugs.
MC-27-47487	Alternator bracket.
MC-29-47441	Upper thermostat housing.
MC-29-78985	Lower thermostat housing.
MC47-488KIT	Thermostat kit (includes gasket and thermostat).
MC47-27-46820	Direct replacement exhaust manifold to head gasket.
MC47-27-46820A1	Exhaust manifold gasket set.
MC47-27-48042	Direct replacement exhaust elbow to manifold gasket.
MC47-27-48043	Direct replacement exhaust manifold end cap/connector gasket (will fit both ends).

Note:

Manifold includes all plugs, gaskets and mounting hardware to head. Riser includes plugs, gasket and mounting hardware to mount to manifold.

MerCruiser V8 Models 330, 340 and 454 Magnum

Inboard and Stern Drive Units

Center Riser Direct Replacement



MC 1 89011

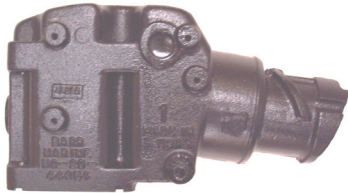

MC 20 44354

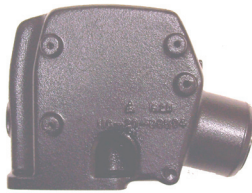

MC 20 98504

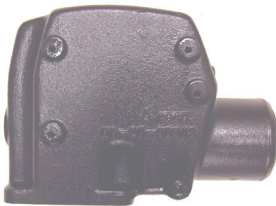

MC 20 98502



MC 20 93320A3

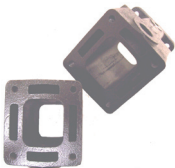

MC 20 93322A3



MC 29 47442



MC 29 90736



MC 27 47487



MC 20 87918



MC 20 99208



MC 50 806926



MC 50 87238

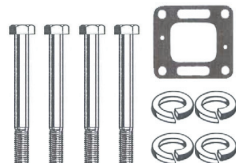

MC 20 44354P

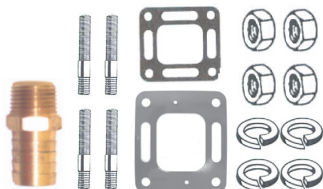

MC 20 98504P



MC47 27 41811



MC47 27 87105



MC47 27 41813



MC47 27 46820

MC-1-89011	Direct replacement water cooled exhaust manifold. Replaces MerCruiser part # 89011A8.
MC-20-44354	Direct replacement water cooled center discharge riser. Replaces MerCruiser part # B-44354A3. Accepts 4" I.D. exhaust hose (8 degree angle).
MC-20-98502	Direct replacement water cooled center discharge riser. Replaces MerCruiser part #98502A2. Accepts 3" I.D. exhaust hose (0 degree angle).
MC-20-98504	Direct replacement water cooled center discharge riser. Replaces MerCruiser part #98504A3. Accepts 3" I.D. exhaust hose (15 degree angle).
MC-20-44354P	Mounting package for MC-20-44354 riser.
MC-20-87918	Direct replacement stainless steel block off plate for use with MerCruiser riser #'s 98502, 98504 and 44354. Requires (2) gaskets part # MC47-27-41813.
MC-20-93320A3	Manifold to riser 3" spacer blocks (pair) with fastener and gasket package.
MC-20-93322A3	Manifold to riser 6" spacer blocks (pair) with fastener and gasket package.
MC-20-98504P	Mounting package for MC-20-98504 riser (includes gaskets, drain plug, pipe plug, stainless steel restrictor plate and fasteners).
MC-20-99208	Direct replacement stainless steel restrictor plate for use with MerCruiser riser #'s 98502, 98504 and 44354. Requires (2) gaskets part # MC47-27-41813.
MC-27-47487	Alternator bracket.
MC-29-47442	Upper thermostat housing.
MC-29-90736	Lower thermostat housing.
MC47-27-41811	Direct replacement restrictor gasket. Replaces MerCruiser part # 27-41811. To be used with MC-20-87918 ((2) required per plate used).
MC47-27-41813	Direct replacement restrictor gasket. Replaces MerCruiser part # 27-41813.
MC47-27-46820	Direct replacement exhaust manifold to head gasket.
MC47-27-87105	Direct replacement exhaust elbow gasket. Replaces MerCruiser part # 27-87105.
MC-50-87238	Exhaust manifold drain cock.
MC-50-806926	Replacement 3/4" N.P.T. X 1" hose fitting (90 degree)/brass drain cock.

Note:

Manifold includes all plugs, gaskets and mounting hardware to head. Risers include plugs, gasket and mounting hardware to mount to manifold.

MerCruiser V8 (Ford)-302 and 351 C.I.D.

All Models Center Riser Generic

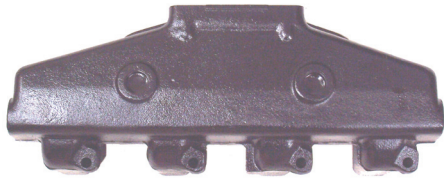

FM 1 83

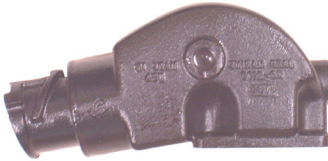

20 0100



20 0082



20 0097



20 0087P



20 0089P



20 0092P



20 0093P



MC 45 0000



MC 6 0001P



MC 6 0000P

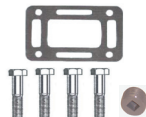

20 0082P



FM 1 83P



1 0104P

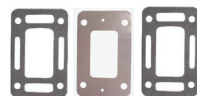

1 0106P



1 0105



1 0107



FM 47 0000

FM-1-83	Water cooled center discharge manifold to fit the small block Ford engine (3/4" N.P.T. cooling hose connections). All years.
20-0082	Water cooled center discharge riser (3/4" N.P.T. cooling hose connection). Standard for use with 3" I.D. exhaust hose.
20-0100	Water cooled center discharge riser (3/4" N.P.T. cooling hose connection). Standard for use with 4" I.D. exhaust hose.
1-0104P	Adaptor package for fresh water cooled manifold (includes gaskets and block off plate).
1-0105	Center riser manifold-to-riser gasket for fresh water cooling.
1-0106P	Adaptor package for raw water cooling. Used in pre-heating applications (includes gaskets and block off plate with vent hole).
1-0107	Center riser manifold-to-riser gasket (raw water cooling).
20-0082P	Riser mounting package for both 20-0082 and 20-0100.
20-0082SS-P	Stainless steel mounting package (with brass plugs) for both 20-0082 and 20-0100. Not pictured.
20-0087P	90 degree exhaust elbow adaptor (includes adaptor, hose and clamps). For use with 3" I.D. exhaust hose.
20-0088P	30 degree exhaust elbow adaptor (includes adaptor, hose and clamps). For use with 2 1/2" I.D. exhaust hose.
20-0089P	30 degree exhaust elbow adaptor (includes adaptor, hose and clamps). For use with 3" I.D. exhaust hose.
20-0092P	45 degree exhaust elbow adaptor (includes adaptor, hose and clamps). For use with 3" I.D. exhaust hose.
20-0093P	90 degree exhaust elbow adaptor (includes adaptor, hose and clamps). For use with 3 1/2" or 4" I.D. exhaust hose.
20-0097	3" spacer block (complete with mounting hardware, gasket and 3/4" pipe plug). Capable of stacking.
FM-1-83P	Manifold mounting package (includes bolts and pipe plugs).
FM-1-83SS-P	Stainless steel manifold mounting package (includes stainless bolts and brass plugs). Not pictured.
FM-47-0000	Manifold to cylinder head gasket.
MC-6-0000P	Exhaust manifold plumbing fittings package for models 188, 255, 233, 255, 302, 351 and 888.
MC-6-0001P	Exhaust manifold plumbing fittings package for model 215.
MC-45 0000	Fuel filter and solenoid universal mounting bracket.

Note:

Manifold includes all plugs, gaskets and mounting hardware to head. Risers include plugs, gasket and mounting hardware to mount to manifold.

MerCruiser V8 (Ford)-302 and 351 C.I.D.

Models 188, 215, 225, 233, 255 and 888 Inboard and I/O Units

Log Style Direct Replacement



MC 1 65603



MC 1 65604

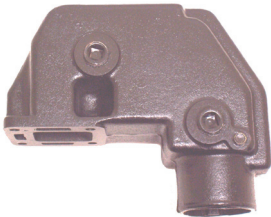

MC 20 60426

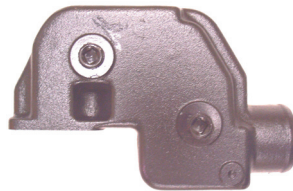

MC 20 76771



MC 20 61851A2



MC 29 63588



MC 29 62898



MC 20 60207



MC 20 55730



1 73813

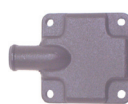

1 60252



1 60252P



1 73813P



MC 20 60426P



MC47 27 48043



MC 1 6560P



MC47 27 99777



MC47 27 73866

MC-1-65603	Direct replacement water cooled exhaust manifold (starboard side). Replaces MerCruiser part # B-65603A4 and B-54099A5.
MC-1-65604	Direct replacement water cooled exhaust manifold (port side). Replaces MerCruiser part # B-65604A4 and B-54100A5.
MC-20-60426	Direct replacement exhaust elbow riser (utilizes a stainless steel sleeve at the water/air mixing area). Replaces MerCruiser part #B-60426A1 (I/O applications).
MC-20-76351	Direct replacement exhaust elbow riser. Replaces MerCruiser part # B-76351A1 (I/O applications). Not pictured.
MC-20-76771	Direct replacement exhaust elbow riser. Replaces MerCruiser part # B-76771A3 (inboard applications).
1-60252	Direct replacement exhaust manifold end cap/connector. Replaces MerCruiser part # B-60252.
1-60252P	Front end plate mounting package.
1-73813	Direct replacement manifold end cap (rear). Supersedes part # 1-54870.
1-73813P	Rear end cap mounting package.
MC-1-6560P	Manifold mounting package.
MC-20-55730	Stainless steel fresh water cooling block off plate for use with MerCruiser riser #'s 60426, 76351 and 76771. Requires (2) gaskets part # MC47-27-99777.
MC-20-60207	Stainless steel block off plate (with vent hole) for use with MerCruiser riser #'s 60426, 76351 and 76771. Requires (2) gaskets part # MC47-27-99777. Used in pre-heating plumbing systems.
MC-20-60426P	Exhaust riser elbow mounting package. For use with both MC-20-60426 and MC-20-76351 risers.
MC-20-61851A2	Manifold to riser 3" spacers (sold in pairs). Includes all mounting hardware, gaskets and drain plugs.
MC-29-62898	Upper thermostat housing.
MC-29-63588	Lower thermostat housing.
MC47-27-48043	Direct replacement exhaust manifold end cap/connector gasket (will fit both ends).
MC47-27-73866	Direct replacement exhaust manifold to head gasket.
MC47-27-99777	Direct replacement exhaust elbow to manifold gasket. Supersedes MerCruiser part # 27-52076.

Note:
Manifold includes all plugs, gaskets and mounting hardware to head. Riser includes plugs, gasket and mounting hardware to mount to manifold.

MerCruiser Exhaust Risers and Accessories

Direct Replacement



MC 20 12076

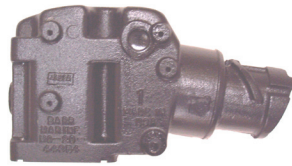

MC 20 44354



MC 20 55538



MC 20 60426

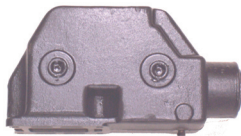

MC 20 72963



MC 20 76325

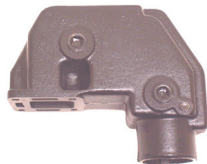

MC 20 76351

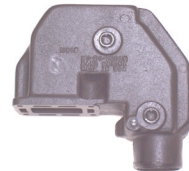

MC 20 76668



MC 20 76771



MC 20 90880



MC 20 98502

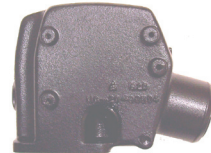

MC 20 98504



MC 20 87918



MC 20 99208



MC 20 60207



MC 20 55730

MC-20-12076	Direct replacement exhaust riser. Replaces MerCruiser part # 12076A2.
MC-20-44354	Direct replacement water cooled center discharge riser. Replaces MerCruiser part # B-44354A3. Accepts 4" I.D. exhaust hose (8 degree angle).
MC-20-55538	Direct replacement exhaust elbow/riser. Replaces MerCruiser part # B-39920 and # B-55538A2.
MC-20-60426	Direct replacement exhaust elbow riser (utilizes a stainless steel sleeve at the water/air mixing area). Replaces MerCruiser part #B-60426A1.
MC-20-72963	Direct replacement exhaust elbow riser. Replaces MerCruiser part # B-72963A1 (inboard applications).
MC-20-76325	Direct replacement exhaust riser. Replaces MerCruiser part # 76325A2.
MC-20-76351	Direct replacement exhaust elbow riser. Replaces MerCruiser part # B-76351A1.
MC-20-76668	Direct replacement exhaust elbow riser. Replaces MerCruiser part # B-76668A3, B-72964A1 and B-47877A4 (I/O applications).
MC-20-76771	Direct replacement exhaust elbow riser. Replaces MerCruiser part # B-76771A3 (inboard applications).
MC-20-90880	Direct replacement (cast iron) exhaust riser/expansion tank. Replaces MerCruiser part # 90880A2.
MC-20-98502	Direct replacement water cooled center discharge riser. Replaces MerCruiser part #98502A2. Accepts 3" I.D. exhaust hose (0 degree angle).
MC-20-98504	Direct replacement water cooled center discharge riser. Replaces MerCruiser part #98504A3. Accepts 3" I.D. exhaust hose (15 degree angle).
MC-20-55730	Stainless steel fresh water cooling block off plate for use with MerCruiser riser #'s 60426, 76351 and 76771. Requires (2) gaskets part # MC47-27-99777.
MC-20-60207	Stainless steel block off plate (with vent hole) for use with MerCruiser riser #'s 60426, 76351 and 76771. Requires (2) gaskets part # MC47-27-99777. Used in pre-heating plumbing systems.
MC-20-87918	Direct replacement stainless steel block off plate for use with MerCruiser riser #'s 98502, 98504 and 44354.
MC-20-99208	Direct replacement stainless steel restrictor plate for use with MerCruiser riser #'s 98502, 98504 and 44354.

Note:

Risers include plugs, gasket and mounting hardware to mount to manifold.

MerCruiser 3" and 6" Riser Kits

Direct Replacement

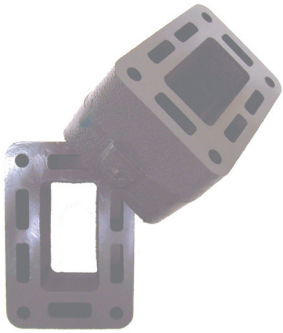

MC 20 61811A4

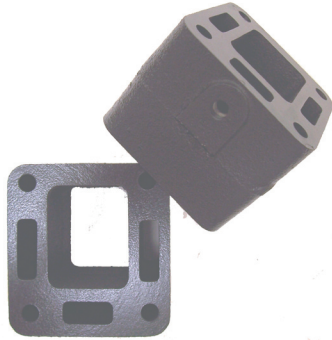

MC 20 61851A2



MC 20 61851A3

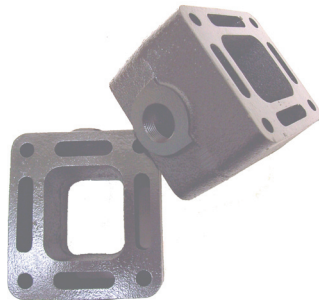

MC 20 93320A3

MC-20-61811A4	Manifold to riser 3" spacers (sold in pairs). Includes all mounting hardware, gaskets and drain plugs.
MC-20-61851A2	Manifold to riser 3" spacers (sold in pairs). Includes all mounting hardware, gaskets and drain plugs.
MC-20-61851A3	Manifold to riser 3" spacer (single block). Includes all mounting hardware, gaskets and drain plug.
MC-20-93320A3	Manifold to riser 3" spacer blocks (pair) with fastener and gasket package.
MC-20-93322A3	Manifold to riser 6" spacer blocks (pair) with fastener and gasket package.
MC-20-61811A4P	Mounting package for MC-20-61811A4 spacer block kit.
MC-20-61852A2P	Mounting package for MC-20-61851A2 spacer block kit.
MC-20-61811A3P	Mounting package for MC-20-61811A3 spacer block kit.
MC-20-93320A3P	Mounting package for MC-20-93320A3 spacer block kit.
MC-20-93322A3P	Mounting package for MC-20-93322A3 spacer block kit.

Note:

Each spacer block kit includes the spacer block (s) and the corresponding package to mount.

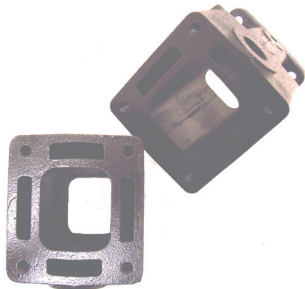

MC 20 93322A3

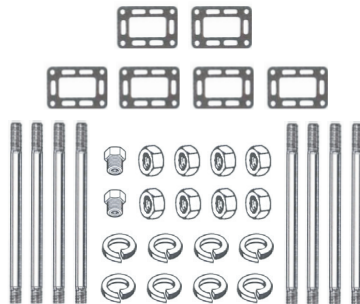

MC 20 61811A4P

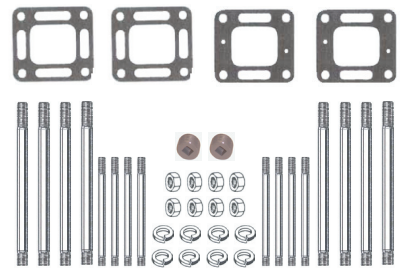

MC 20 93320A3P

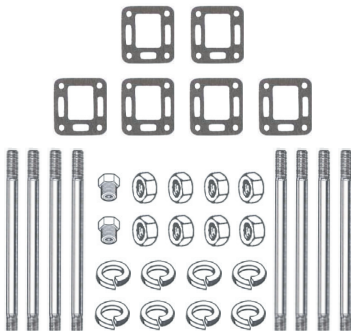

MC 20 61851A2P

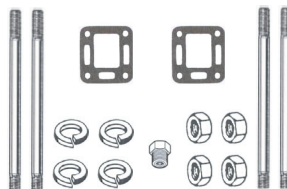

MC 20 61851A3P

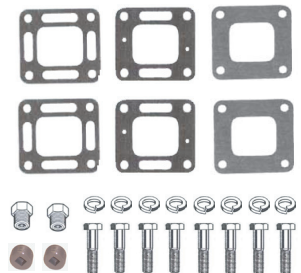

MC 20 93320A3P

MerCruiser Thermostat Housing Assemblies



MC 29 47441



MC 29 47587



MC 29 60372



MC 29 62898



MC 29 63588



MC 29 78984



MC 29 78985



MC 29 87290

Part#

Detailed Description

MC-29-60372	Upper Thermostat Housing - Models 120, 140, 120R/140R, 160, 165 and 200
MC47-27-47590	Upper Thermostat Housing Gasket - Models 120, 140, 120R/140R, 160, 165 and 200
MC-29-47587	Lower Thermostat Housing - Models 120, 140, 120R/140R, 160, 165 and 200
MC47-27-33680	Lower Thermostat Housing Gasket - Models 120, 140, 120R/140R, 160, 165 and 200
MC-29-59078	Thermostat - Models 120, 140, 120R/140R, 160, 165 and 200
MC-29-47441	Upper Thermostat Housing - Models 225 (GM), 260, 228, 898/198
MC47-27-48818	Upper Thermostat Housing Gasket - Models 225 (GM), 260, 228, 898/198
MC-29-78984	Lower Thermostat Housing Gasket - Models 225 (GM), 260, 228, 898/198
MC47-27-53045	Lower Thermostat Housing Gasket - Models 225 (GM), 260, 228, 898/198
MC-29-59137	Thermostat - Models 225 (GM), 260, 228, 898/198
MC-29-59498	Upper Thermostat Housing - Models 888, 225 (Ford), 233 (Ford) and 255 (Ford)
MC-29-62898	Upper Thermostat Housing - Models 888, 225 (Ford), 233 (Ford) and 255 (Ford)
MC47-27-60208	Upper Thermostat Housing Gasket - Models 888, 225 (Ford), 233 (Ford) and 255 (Ford)
MC-29-60783	Lower Thermostat Housing - Models 888, 225 (Ford), 233 (Ford) and 255 (Ford)
MC-29-63588	Lower Thermostat Housing - Models 888, 225 (Ford), 233 (Ford) and 255 (Ford)
MC47-27-54506	Lower Thermostat Housing Gasket - Models 888, 225 (Ford), 233 (Ford) and 255 (Ford)
MC-29-59137	Thermostat - Models 888, 225 (Ford), 233 (Ford) and 255 (Ford)
MC-29-47441	Upper Thermostat Housing - Models 185R and 898R/228R/260R
MC47-27-41812	Upper Thermostat Housing Gasket - Models 185R and 898R/228R/260R
MC-29-87290	Lower Thermostat Housing - Models 185R and 898R/228R/260R
MC47-27-53045	Lower Thermostat Housing Gasket - Models 185R and 898R/228R/260R
MC-29-59137	Thermostat - Models 185R and 898R/228R/260R
MC-29-97429	Upper Thermostat Housing - Models 230 (Inboard) and 260 (Inboard)
MC47-27-90556	Upper Thermostat Housing Gasket - Models 230 (Inboard) and 260 (Inboard)
MC-29-87290	Lower Thermostat Housing - Models 230 (Inboard) and 260 (Inboard)
MC47-27-53045	Lower Thermostat Housing Gasket - Models 230 (Inboard) and 260 (Inboard)
MC-29-59137	Thermostat - Models 230 (Inboard) and 260 (Inboard)
MC-29-47442	Upper Thermostat Housing - Models 330 (GM)
MC47-27-48818	Upper Thermostat Housing Gasket - Models 330 (GM)
MC-29-78985	Lower Thermostat Housing - Models 330 (GM)
MC-29-79468	Lower Thermostat Housing - Models 330 (GM)
MC47-27-53045	Lower Thermostat Housing Gasket - Models 330 (GM)
MC-29-59137	Thermostat - Models 330 (GM)
MC-29-47442	Upper Thermostat Housing - Models 330 (Inboard) and 340 (Inboard)
MC-29-97428	Upper Thermostat Housing - Models 330 (Inboard) and 340 (Inboard)
MC47-27-90556	Upper Thermostat Housing Gasket - Models 330 (Inboard) and 340 (Inboard)
MC-29-90736	Lower Thermostat Housing - Models 330 (Inboard) and 340 (Inboard)
MC47-27-53405	Lower Thermostat Housing Gasket - Models 330 (Inboard) and 340 (Inboard)
MC-29-59137	Lower Thermostat - Models 330 (Inboard) and 340 (Inboard)
MC-29-47442	Upper Thermostat Housing - Models 325, 350
MC47-27-48818	Upper Thermostat Housing Gasket - Models 325, 350
MC-29-47479	Lower Thermostat Housing - Models 325, 350
MC-29-49966	Lower Thermostat Housing - Models 325, 350
MC-29-52852	Lower Thermostat Housing - Models 325, 350
MC-29-78985	Lower Thermostat Housing - Models 325, 350
MC47-27-53045	Lower Thermostat Housing Gasket - Models 325, 350
MC-29-59137	Thermostat - Models 325, 350

MerCruiser Thermostat Kits



MC47 475KIT

Contents:
MC47-27-47590 Gasket
MC-29-59078 Thermostat



MC47 488KIT

Contents:
MC47-27-48818 Gasket
MC-29-59137 Thermostat

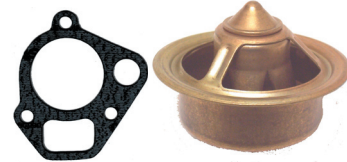

MC47 602KIT

Contents:
MC47-27-60208 Gasket
MC-29-59137 Thermostat

Part #	Detailed Description
MC47-475KIT	Thermostat Kit 475 - Engine model 120 Beginning S/N 2324347 - Ending S/N 337734. Note MC47 475 Kit Contents: MC47-27-47590 Gasket and MC-29-59078 Thermostat
MC47-475KIT	Thermostat Kit 475 - Engine model 120 Beginning S/N 3377341 - Ending S/N Up. Note MC47 475 Kit Contents: MC47-27-47590 Gasket and MC-29-59078 Thermostat
MC47-475KIT	Thermostat Kit 475 - Engine model 140 Beginning S/N 2508261 - Ending S/N Up. Note MC47 475 Kit Contents: MC47-27-47590 Gasket and MC-29-59078 Thermostat
MC47-475KIT	Thermostat Kit 475 - Engine model 165 Beginning S/N 3377341 - Ending S/N Up. Note MC47 475 Kit Contents: MC47-27-47590 Gasket and MC-29-59078 Thermostat
MC47-488KIT	Thermostat Kit 488 - Engine model 198 Beginning S/N 4776402 - Ending S/N 6218461. Note MC47 488 Kit Contents: MC47-27-48818 Gasket and MC-29-59137 Thermostat
MC47-602KIT	Thermostat Kit 602 - Engine model 215 Beginning S/N 3040411 - Ending S/N Up. Note MC47 602 Kit Contents: MC47-27-60208 Gasket and MC-29-59137 Thermostat
MC47-488KIT	Thermostat Kit 488 - Engine model 225 Beginning S/N 2278647 - Ending S/N 2694014. Note MC47 488 Kit Contents: MC47-27-48818 Gasket and MC-29-59137 Thermostat
MC47-602KIT	Thermostat Kit 602 - Engine model 225 Beginning S/N 3385721 - Ending S/N Up. Note MC47 602 Kit Contents: MC47-27-60208 Gasket and MC-29-59137 Thermostat
MC47-488KIT	Thermostat Kit 488 - Engine model 228 Beginning S/N 4765100 - Ending S/N 2618461. Note MC47 488 Kit Contents: MC47-27-48818 Gasket and MC-29-59137 Thermostat
MC47-488KIT	Thermostat Kit 488 - Engine model 230 Beginning S/N 6040716 - Ending S/N Up. Note MC47 488 Kit Contents: MC47-27-48818 Gasket and MC-29-59137 Thermostat
MC47-602KIT	Thermostat Kit 602 - Engine model 233 Beginning S/N 4173000 - Ending S/N Up. Note MC47 602 Kit Contents: MC47-27-60208 Gasket and MC-29-59137 Thermostat
MC47-488KIT	Thermostat Kit 488 - Engine model 250 Beginning S/N 2314301 - Ending S/N 2639854. Note MC47 488 Kit Contents: MC47-27-48818 Gasket and MC-29-59137 Thermostat
MC47-488KIT	Thermostat Kit 488 - Engine model 250 Beginning S/N 4768000 - Ending S/N 4908849. Note MC47 488 Kit Contents: MC47-27-48818 Gasket and MC-29-59137 Thermostat
MC47-602KIT	Thermostat Kit 602 - Engine model 255 Beginning S/N 3258728 - Ending S/N Up. Note MC47 602 Kit Contents: MC47-27-60208 Gasket and MC-29-59137 Thermostat
MC47-488KIT	Thermostat Kit 488 - Engine model 255 Beginning S/N 4175500 - Ending S/N Up. Note MC47 488 Kit Contents: MC47-27-48818 Gasket and MC-29-59137 Thermostat
MC47-488KIT	Thermostat Kit 488 - Engine model 260 Beginning S/N 5907058 - Ending S/N Up. Note MC47 488 Kit Contents: MC47-27-48818 Gasket and MC-29-59137 Thermostat
MC47-488KIT	Thermostat Kit 488 - Engine model 270 Beginning S/N 2851074 - Ending S/N 3077735. Note MC47 488 Kit Contents: MC47-27-48818 Gasket and MC-29-59137 Thermostat
MC47-488KIT	Thermostat Kit 488 - Engine model 280 Beginning S/N 4176250 - Ending S/N Up. Note MC47 488 Kit Contents: MC47-27-48818 Gasket and MC-29-59137 Thermostat
MC47-488KIT	Thermostat Kit 488 - Engine model 325 Beginning S/N 2288747 - Ending S/N Up. Note MC47 488 Kit Contents: MC47-27-48818 Gasket and MC-29-59137 Thermostat
MC47-488KIT	Thermostat Kit 488 - Engine model 330 Beginning S/N 4623115 - Ending S/N Up. Note MC47 488 Kit Contents: MC47-27-48818 Gasket and MC-29-59137 Thermostat
MC47-488KIT	Thermostat Kit 488 - Engine model 340 Beginning S/N 5889914 - Ending S/N Up. Note MC47 488 Kit Contents: MC47-27-48818 Gasket and MC-29-59137 Thermostat
MC47-488KIT	Thermostat Kit 488 - Engine model 350 Beginning S/N 3780450 - Ending S/N Up. Note MC47 488 Kit Contents: MC47-27-48818 Gasket and MC-29-59137 Thermostat
MC47-488KIT	Thermostat Kit 488 - Engine model 370 Beginning S/N 4179554 - Ending S/N Up. Note MC47 488 Kit Contents: MC47-27-48818 Gasket and MC-29-59137 Thermostat
MC47-488KIT	Thermostat Kit 488 - Engine model 390 Beginning S/N 2781129 - Ending S/N 2825059. Note MC47 488 Kit Contents: MC47-27-48818 Gasket and MC-29-59137 Thermostat
MC47-602KIT	Thermostat Kit 602 - Engine model 888 Beginning S/N 3108723 - Ending S/N Up. Note MC47 602 Kit Contents: MC47-27-60208 Gasket and MC-29-59137 Thermostat
MC47-488KIT	Thermostat Kit 488 - Engine model 898 Beginning S/N 4762210 - Ending S/N 6218461. Note MC47 488 Kit Contents: MC47-27-48818 Gasket and MC-29-59137 Thermostat

OMC 4-Cylinder 153 C.I.D. 120 H.P. 2.5 Liter

Model 120 Engine

Log Style Direct Replacement



OMC 1 981462

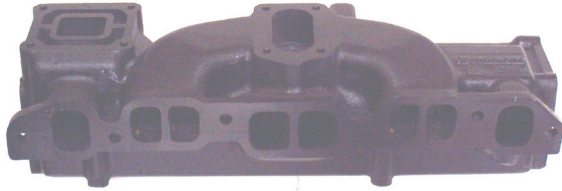

OMC 1 982657



OMC 20 980536



OMC 20 910380



OMC 20 909368



OMC 20 907765



OMC 20 908014



1-907885



1-910280



1-910384



OMC 20 910380P

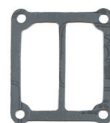

OMC47 907761



OMC47 908013

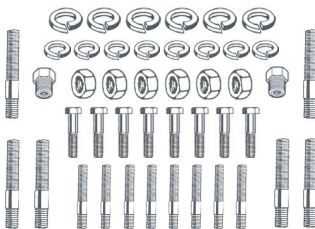

OMC 1 98146/982



1-380446



OMC47 907764

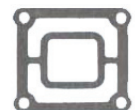

OMC47 311068

OMC47 311121

OMC-1-981462	Direct replacement water cooled exhaust manifold. Replaces OMC part #'s 979729 and 980459.
OMC-1-982657	Direct replacement water cooled exhaust manifold. Manifold has the heat source in the exhaust port for automatic choke.
OMC-20-909368	Direct replacement high rise to adaptor elbow for use with OMC-20-980536.
OMC-20-910380	Direct replacement exhaust elbow. Replaces OMC riser part #'s 980188 and 910380.
OMC-20-980536	Direct replacement exhaust riser. Replaces OMC riser part #'s 979730 and 980536.
1-380446	Heat exchanger assembly.
1-907885	Direct replacement rear end cap. Replaces OMC part # 907885.
1-910280	Direct replacement front end cap. Replaces OMC part # 910280 and 311550 (choke).
1-910384	Direct replacement front end cap. Replaces OMC part # 910384.
OMC-1-98146/982	Manifold mounting package.
OMC-20-907765	Direct replacement exhaust elbow to hose adaptor.
OMC-20-908014	Exhaust manifold to riser adaptor for use with OMC riser part #'s 980188 and 910380.
OMC-20-910380P	Exhaust riser mounting package.
OMC47-311068	Exhaust manifold to cylinder head gasket.
OMC47-311121	Exhaust manifold to elbow and end cap gasket.
OMC47-907761	Manifold end cap gasket.
OMC47-907764	Exhaust elbow to hose adaptor gasket.
OMC47-908013	Adaptor plate (OMC-20-908014) to riser (OMC-20-910380) gasket.

Note:

Manifold includes all plugs, gaskets and mounting hardware to head. Risers include plugs, gasket and mounting hardware to mount to manifold.

OMC 4-Cylinder 181 C.I.D. 140 H.P. 3.0 Liter

Model 140 Engine

Log Style Direct Replacement

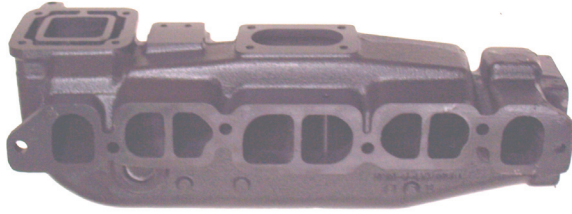

OMC 1 984054



OMC 20 910380

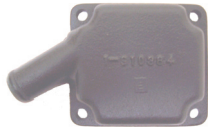

1-910384



OMC 1 984054P



OMC 20 910380P

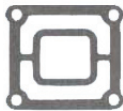

OMC47 311121



OMC47 908013



OMC47 908079

OMC-1-984054	Direct replacement exhaust manifold. Replaces OMC part #'s 998083, 980460, 980957 and 982490.
OMC-20-910380	Direct replacement exhaust elbow. Replaces OMC riser part #'s 980188 and 910380.
1-910384	Direct replacement front end cap. Replaces OMC part # 910384.
OMC-1-984054P	Exhaust manifold mounting package.
OMC-20-910380P	Exhaust riser mounting package.
OMC47-311121	Exhaust manifold to elbow and end cap gasket.
OMC47-908013	Adaptor plate (OMC-20-908014) to riser (OMC-20-910380) gasket.
OMC47-908079	Exhaust manifold to cylinder head gasket.

Note:

Manifold includes all plugs, gaskets and mounting hardware to head. Risers include plugs, gasket and mounting hardware to mount to manifold.

OMC V6-155 H.P. All Years

Log Style Generic

Port side part # BV6 1 75L.

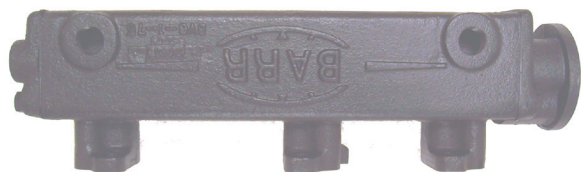

BV6 1 75R



20 0031

BV6-1-75L	Water cooled end discharge port manifold to fit the Buick V6 engine (1/2" N.P.T. cooling connections). All years.
BV6-1-75R	Water cooled end discharge starboard manifold to fit the Buick V6 engine (1/2" N.P.T. cooling connections). All years.
20-0031	Swivel-type 90 degree exhaust elbow connector with internal water discharge. Accepts 2 1/2" to 3" I.D. exhaust hose. Requires (1) mounting hardware kit #20-0002P per elbow.
OMC-1-0092	Front end plate with choke stove heat exchanger (starboard side only).
OMC-6-0000P	Plumbing fittings package (3/4" I.D. hose only).
OMC-29-0000	Upper thermostat housing. Replaces either OMC # 314810 or # 982201 (may also order under part #'s OMC-29-314810 or OMC-29-982201).
OMC-29-383307	160 degree thermostat.
OMC47-314809	Thermostat housing gasket.



OMC 1 0092



OMC 29 0000



OMC47 314809



OMC 29 383307

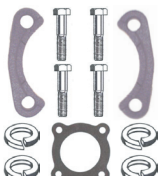

20 0002P



OMC 6 0000P

OMC V6-155 H.P. All Years

Log Style Direct Replacement



OMC 1 979758



OMC 1 979759



OMC 20 981281



OMC 29 0000



OMC 29 383307



1 312148



1 312149



1 380985



1 31214P



OMC 20 981281P



OMC 1 97975P



OMC 1 9797P



OMC47 314809



OMC47 907775



OMC47 311130

OMC-1-979758	Direct replacement exhaust manifold (port side). Replaces OMC part # 979758.
OMC-1-979759	Direct replacement exhaust manifold (starboard side). Replaces OMC part #979759.
OMC-20-981281	Direct replacement exhaust elbow. Replaces OMC part #'s 907776 and # 907777.
1-31214P	Exhaust manifold end cap/connector mounting package.
1-312148	Direct replacement exhaust manifold front end cap/connector (port side).
1-312149	Direct replacement exhaust manifold front end cap/connector (starboard side). End cap has extra hole drilled for choke stove.
1-380985	Choke stove heat exchanger (starboard side only). Uses 1-312149 end cap.
OMC-1-9797P	End cap and exhaust elbow stud package.
OMC-1-97975P	Exhaust manifold mounting package.
OMC-20-981281P	Exhaust elbow mounting package.
OMC-29-383307	160 degree thermostat.
OMC-29-0000	Upper thermostat housing. Replaces either OMC # 314810 or # 982201 (may also order under part #'s OMC-29-314810 or OMC-29-982201).
OMC47-311130	Direct replacement exhaust manifold end cap/connector gasket (not to be used between elbow and manifold).
OMC47-314809	Thermostat housing gasket.
OMC47-907775	Direct replacement exhaust elbow gasket.

Note:
 Manifold includes all plugs, gaskets and mounting hardware to head. Risers include plugs, gasket and mounting hardware to mount to manifold.

OMC V8-283, 305, 307, and 350 C.I.D.

Models 210, 215, 225, 235 and 245 H.P.

Log Style Generic

Port side part # OF 1 60L.



OF 1 60R



20 0031



20 0055

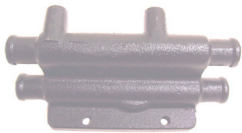

OMC 29 0000



OMC 29 383307



OMC 6 0000P

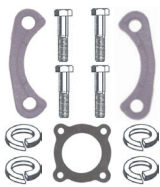

20 0002P

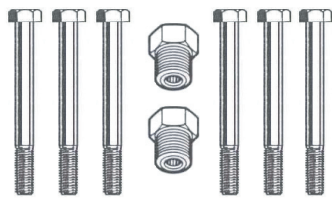

OF 1 60F P



OMC47 909314



OMC47 314809



OMC47 909515

OF-1-60L	Water cooled end discharge port manifold to fit the Small Block GM engine (1/2" N.P.T. cooling hose connections).
OF-1-60R	Water cooled end discharge starboard manifold to fit the Small Block GM engine (1/2" N.P.T. cooling hose connections).
20-0031	Swivel-type 90 degree exhaust elbow connector with internal water discharge. Accepts 2 1/2" to 3" I.D. exhaust hose. Requires (1) mounting hardware kit #20-0002P per elbow.
20-0055	Swivel-type 30 degree exhaust elbow connector; fully jacketed. Accepts 2 1/2" or 3" I.D. exhaust hose. Requires (1) mounting hardware kit #20-0002P per elbow.
20-0002P	Mounting hardware kit.
OF-1-60F-P	Manifold to cylinder head mounting package.
OMC-6-0000P	Plumbing fittings package (3/4" I.D. hose only).
OMC-29-0000	Upper thermostat housing. Replaces either OMC # 314810 or # 982201 (may also order under part #'s OMC-29-314810 or OMC-29-982201).
OMC-29-383307	160 degree thermostat.
OMC47-314809	Thermostat housing gasket.
OMC47-909314	Exhaust manifold to cylinder head gasket.
OMC47-909515	Adaptor housing gasket.

OMC V8-283, 305, 307 and 350 C.I.D.

Models 225, and 245 H.P.

Log Style Direct Replacement

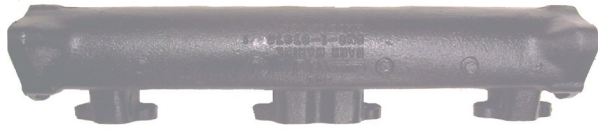

OMC 1 979760



OMC 1 979761



OMC 20 981281



OMC 29 0000



OMC 29 383307



1 312148



1 312149



1 380985



1 31214P



OMC 20 981281P

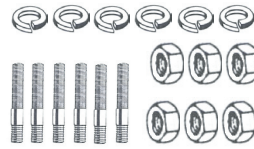

OMC 1 97975P



OMC 1 9797P



OMC47 314809



OMC47 907775



OMC47 311130



OMC47 909314

OMC-1-979760	Direct replacement exhaust manifold (port side). Replaces OMC part # 979760.
OMC-1-979761	Direct replacement exhaust manifold (starboard side). Replaces OMC part #979761.
OMC-20-981281	Direct replacement exhaust elbow. Replaces OMC part #'s 907776 and # 907777.
1-31214P	Exhaust manifold end cap/connector mounting package.
1-312148	Direct replacement exhaust manifold front end cap/connector (port side).
1-312149	Direct replacement exhaust manifold front end cap/connector (starboard side). End cap has extra hole drilled for choke stove.
1-380985	Choke stove heat exchanger (starboard side only). Uses 1-312149 end cap.
OMC-1-9797P	End cap and exhaust elbow stud package.
OMC-1-97975P	Exhaust manifold mounting package.
OMC-20-981281P	Exhaust elbow mounting package.
OMC-29-383307	160 degree thermostat.
OMC-29-0000	Upper thermostat housing. Replaces either OMC # 314810 or # 982201 (may also order under part #'s OMC-29-314810 or OMC-29-982201).
OMC47-311130	Direct replacement exhaust manifold end cap/connector gasket (not to be used between elbow and manifold).
OMC47-314809	Thermostat housing gasket.
OMC47-907775	Direct replacement exhaust elbow gasket.
OMC47-909314	Manifold to cylinder head gasket.

Note:

Manifold includes all plugs, gaskets and mounting hardware to head. Risers include plugs, gasket and mounting hardware to mount to manifold.

OMC V8-283, 305, 307 and 350 C.I.D.

Models 185, 200, 225, 230, and 260 H.P.

Log Style Direct Replacement



OMC 1 912441



OMC 1 912442



OMC 20 982680

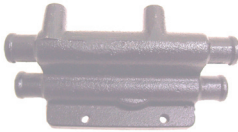

OMC 29 0000



OMC 29 383307

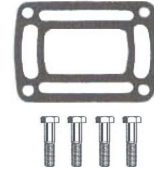

OMC 20 982680P



OMC47 909314

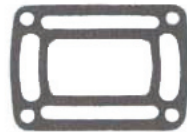

OMC47 909786

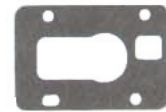

OMC47 314809

OMC-1-912441	Direct replacement exhaust manifold (starboard side). Replaces OMC part #'s 912441 and 909280.
OMC-1-912442	Direct replacement exhaust manifold (port side). Replaces OMC part #'s #'s 912442 and 910144.
OMC-20-982680	Direct replacement exhaust riser/elbow. Replaces OMC part # 982680.
OMC-20-982680P	Exhaust riser/elbow mounting package.
OMC-29-0000	Upper thermostat housing. Replaces either OMC # 314810 or # 982201 (may also order under part #'s OMC-29-314810 or OMC-29-982201).
OMC-29-383307	160 degree thermostat.
OMC47-314809	Thermostat housing gasket.
OMC47-909314	Exhaust manifold to cylinder head gasket.
OMC47-909786	Direct replacement exhaust riser to manifold gasket.

Note:
Manifold includes all plugs, gaskets and mounting hardware to head. Risers include plugs, gasket and mounting hardware to mount to manifold.

OMC V8-283, 302, 305, 307, and 350 C.I.D. All Models Center Riser Generic



CHV 1 83

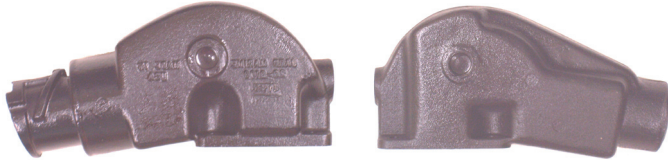

20 0100

20 0082



20 0097



20 0084P

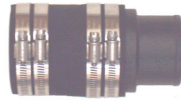

20 0085P



20 0086P



20 0087P



20 0088P



20 0089P



20 0092P



20 0093P



MC 6 0001P



OMC 20 0003



CHV 1 83P

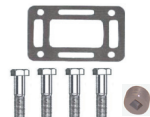

20 0082P

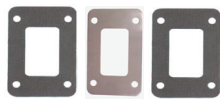

1 0104P

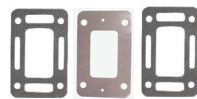

1 0106P



1 0105



1 0107



CHV 47 0000

CHV-1-83	Water cooled center discharge manifold to fit the small block GM engine (3/4" N.P.T. cooling hose connections). All years.
20-0082	Water cooled center discharge riser (3/4" N.P.T. cooling hose connection). Standard for use with 3" I.D. exhaust hose.
20-0100	Water cooled center discharge riser (3/4" N.P.T. cooling hose connection). Standard for use with 4" I.D. exhaust hose.
1-0104P	Adaptor package for fresh water cooled manifold (includes gaskets and block off plate).
1-0105	Center riser manifold-to-riser gasket for fresh water cooling.
1-0106P	Adaptor package for raw water cooling. Used in pre-heating applications (includes gaskets and block off plate with vent hole).
1-0107	Center riser manifold-to-riser gasket (raw water cooling).
20-0082P	Riser mounting package for both 20-0082 and 20-0100.
20-0082SS-P	Stainless steel mounting package (with brass plugs) for both 20-0082 and 20-0100. Not pictured.
20-0084P	Straight exhaust adaptor (includes adaptor, hose and clamps). For use with 3 1/2" I.D. exhaust hose.
20-0085P	Straight exhaust adaptor (includes adaptor, hose and clamps). For use with 2 1/2" I.D. exhaust hose.
20-0086P	90 degree exhaust elbow adaptor for I/O applications (includes adaptor, hose and clamps). For use with 2 1/2" I.D. exhaust hose.
20-0087P	90 degree exhaust elbow adaptor (includes adaptor, hose and clamps). For use with 3" I.D. exhaust hose.
20-0088P	30 degree exhaust elbow adaptor (includes adaptor, hose and clamps). For use with 2 1/2" I.D. exhaust hose.
20-0089P	30 degree exhaust elbow adaptor (includes adaptor, hose and clamps). For use with 3" I.D. exhaust hose.
20-0092P	45 degree exhaust elbow adaptor (includes adaptor, hose and clamps). For use with 3" I.D. exhaust hose.
20-0093P	90 degree exhaust elbow adaptor (includes adaptor, hose and clamps). For use with 3 1/2" or 4" I.D. exhaust hose.
20-0097	3" spacer block (complete with mounting hardware, gasket and 3/4" pipe plug). Capable of stacking.
CHV-1-83P	Manifold mounting package (includes bolts and pipe plugs).
CHV-1-83SS-P	Stainless steel manifold mounting package (includes stainless bolts and brass plugs). Not pictured.
CHV-47-0000	Manifold to cylinder head gasket.
MC-6-0001P	Exhaust manifold plumbing fittings package for model 215.
OMC-20-0003	Hose bushing 3" to 3 1/2" (where applicable).

Note:

Manifold includes all plugs, gaskets and mounting hardware to head. Risers include plugs, gasket and mounting hardware to mount to manifold.

OMC/VOLVO V8- 5.7 Liter Cobra

All Models

Center Riser Direct Replacement

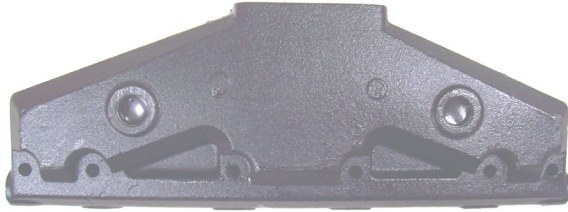

OMC 1 914035

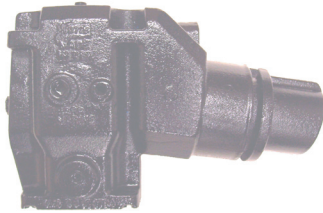

OMC 20 913784

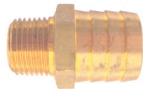

50 512 017



OMC 20 913784P



OMC 1 914035P



OMC47 909314

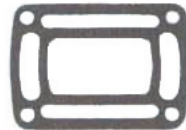

OMC47 913783

OMC-1-914035	Direct replacement exhaust manifold. Replaces OMC part # 914035 and Volvo part # 3857723 (New Style).
OMC-20-913784	Direct replacement exhaust riser/elbow. Replaces OMC # 913784 and Volvo part # 3863061 (New Style).
OMC-1-914035P	Exhaust manifold mounting package.
OMC-20-913784P	Exhaust riser/elbow mounting package.
OMC47-909314	Exhaust manifold to cylinder head gasket.
OMC47-913783	Direct replacement exhaust riser/elbow to manifold gasket.
50-512-017	Replacement 1/2" N.P.T. to 1" hose (straight)/brass hose fitting.

Note:

Manifold includes all plugs, gaskets and mounting hardware to head. Risers include plugs, gasket and mounting hardware to mount to manifold.

OMC (Ford) V8-302 and 351 C.I.D.

Models 170, 175, 190 and 235 H.P.
Direct Replacement



OMC 1 980959



OMC 20 980617

OMC-1-980959	Direct replacement exhaust manifold. Replaces OMC part # 980572 and # 980959.
OMC-20-980617	Direct replacement exhaust elbow. Replaces OMC part # 980617.
1-908719	Direct replacement exhaust manifold end cap/connector (front). Replaces OMC part # 908719.
OMC-1-980959P	Manifold to cylinder head mounting package.
OMC-20-980617P	Exhaust elbow mounting package.
OMC47-908717	Exhaust manifold to cylinder head gasket.
OMC47-908935	Direct replacement exhaust manifold end cap/connector gasket.

Note:
Manifold includes all plugs, gaskets and mounting hardware to head. Risers include plugs, gasket and mounting hardware to mount to manifold.



1 908719

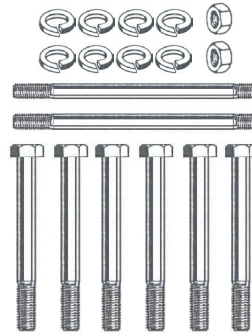

OMC 1 980959P

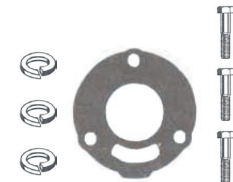

OMC 20 980617P



OMC47 908935



OMC47 908717

OMC (Ford) V8-302 and 351 C.I.D.

All Models Center Riser Generic

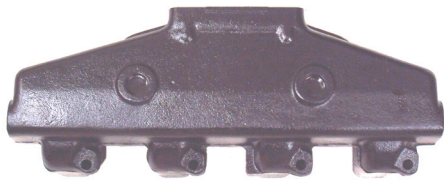

FM 1 83

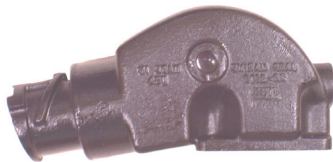

20 0100

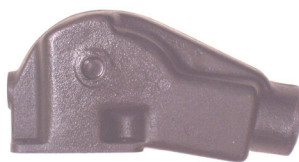

20 0082



20 0097



20 0087P



20 0088P



20 0089P



20 0092P



20 0093P



MC 6 0001P



OMC 6 0000P



OMC 20 0000P



OMC 20 0003



20 0082P



FM 1 83P



1 0104P



1 0106P



1 0105



1 0107



FM 47 0000

FM-1-83	Water cooled center discharge manifold to fit the small block Ford engine (3/4" N.P.T. cooling hose connections). All years.
20-0082	Water cooled center discharge riser (3/4" N.P.T. cooling hose connection). Standard for use with 3" I.D. exhaust hose.
20-0100	Water cooled center discharge riser (3/4" N.P.T. cooling hose connection). Standard for use with 4" I.D. exhaust hose.
1-0104P	Adaptor package for fresh water cooled manifold (includes gaskets and block off plate).
1-0105	Center riser manifold-to-riser gasket for fresh water cooling.
1-0106P	Adaptor package for raw water cooling. Used in pre-heating applications (includes gaskets and block off plate with vent hole).
1-0107	Center riser manifold-to-riser gasket (raw water cooling).
20-0082P	Riser mounting package for both 20-0082 and 20-0100.
20-0082SS-P	Stainless steel mounting package (with brass plugs) for both 20-0082 and 20-0100. Not pictured.
20-0087P	90 degree exhaust elbow adaptor (includes adaptor, hose and clamps). For use with 3" I.D. exhaust hose.
20-0088P	30 degree exhaust elbow adaptor (includes adaptor, hose and clamps). For use with 2 1/2" I.D. exhaust hose.
20-0089P	30 degree exhaust elbow adaptor (includes adaptor, hose and clamps). For use with 3" I.D. exhaust hose.
20-0092P	45 degree exhaust elbow adaptor (includes adaptor, hose and clamps). For use with 3" I.D. exhaust hose.
20-0093P	90 degree exhaust elbow adaptor (includes adaptor, hose and clamps). For use with 3 1/2" or 4" I.D. exhaust hose.
20-0097	3" spacer block (complete with mounting hardware, gasket and 3/4" pipe plug). Capable of stacking.
FM-1-83P	Manifold mounting package (includes bolts and pipe plugs).
FM-1-83SS-P	Stainless steel manifold mounting package (includes stainless bolts and brass plugs). Not pictured.
FM-47-0000	Manifold to cylinder head gasket.
MC-6-0001P	Exhaust manifold plumbing fittings package (1" I.D. hose only).
OMC-6-0000P	Exhaust manifold plumbing fittings package (3/4" hose only).
OMC-20-0000P	Hook up package; may be required for connection to stern drive units (exhaust hose and clamps not included).
OMC-20-0003	Hose bushing 3" to 3 1/2" (where applicable).

Note:
Manifold includes all plugs, gaskets and mounting hardware to head. Risers include plugs, gasket and mounting hardware to mount to manifold.

Perkins Diesel 160 H.P. 354 C.I.D. Model T6.354M



PE 1 6354



PE 1 6354B

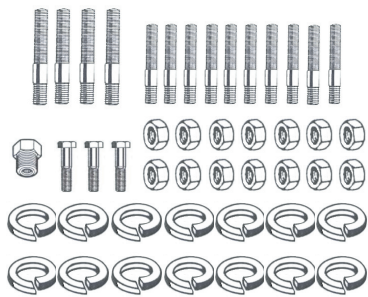

PE 1 6354P

PE-1-6354	Water cooled exhaust manifold (includes mounting hardware to head). Replaces Perkins part number 89058.
PE-1-6354B	Cover plate. Replaces Perkins part # 35732861.
PE-1-6354P	Manifold mounting kit.

Note:

The manifold will fit vertical or inclined models and will accept all of the original end plates, fittings, gaskets and hardware. It will not fit engines equipped with a combined exhaust manifold heat exchanger, nor is it applicable to naturally aspirated models.

Pleasurecraft V8-302 and 351 C.I.D. All Years

Center Riser Generic

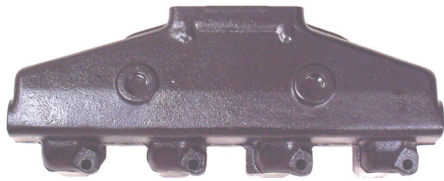

FM 1 83

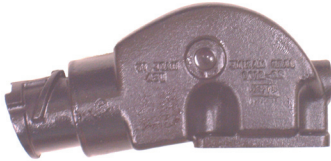

20 0100



20 0082



20 0102



20 0097

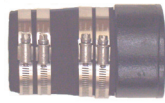

20 0084P

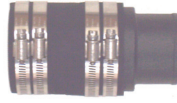

20 0085P



20 0086P



20 0087P



20 0088P



20 0089P



20 0092P



20 0093P



20 0082P



FM 1 83P



1 0104P

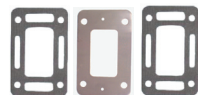

1 0106P



1 0105



1 0107



FM 47 0000

FM-1-83	Water cooled center discharge manifold to fit the small block Ford engine (3/4" N.P.T. cooling hose connections). All years.
20-0082	Water cooled center discharge riser (3/4" N.P.T. cooling hose connection). Standard for use with 3" I.D. exhaust hose.
20-0100	Water cooled center discharge riser (3/4" N.P.T. cooling hose connection). Standard for use with 4" I.D. exhaust hose.
20-0102	Water cooled center discharge riser (3/4" N.P.T. cooling hose connection).
1-0104P	Adaptor package for fresh water cooled manifold (includes gaskets and block off plate).
1-0105	Center riser manifold-to-riser gasket for fresh water cooling.
1-0106P	Adaptor package for raw water cooling. Used in pre-heating applications (includes gaskets and block off plate with vent hole).
1-0107	Center riser manifold-to-riser gasket (raw water cooling).
20-0082P	Riser mounting package for both 20-0082 and 20-0100.
20-0082SS-P	Stainless steel mounting package (with brass plugs) for both 20-0082 and 20-0100. Not pictured.
20-0084P	Straight exhaust adaptor (includes adaptor, hose and clamps). For use with 3 1/2" I.D. exhaust hose.
20-0085P	Straight exhaust adaptor (includes adaptor, hose and clamps). For use with 2 1/2" I.D. exhaust hose.
20-0086P	90 degree exhaust elbow adaptor (includes adaptor, hose and clamps). For use with 2 1/2" I.D. exhaust hose.
20-0087P	90 degree exhaust elbow adaptor (includes adaptor, hose and clamps). For use with 3" I.D. exhaust hose.
20-0088P	30 degree exhaust elbow adaptor (includes adaptor, hose and clamps). For use with 2 1/2" I.D. exhaust hose.
20-0089P	30 degree exhaust elbow adaptor (includes adaptor, hose and clamps). For use with 3" I.D. exhaust hose.
20-0092P	45 degree exhaust elbow adaptor (includes adaptor, hose and clamps). For use with 3" I.D. exhaust hose.
20-0093P	90 degree exhaust elbow adaptor (includes adaptor, hose and clamps). For use with 3 1/2" or 4" I.D. exhaust hose.
20-0097	3" spacer block (complete with mounting hardware, gasket and 3/4" pipe plug). Capable of stacking.
FM-1-83P	Manifold mounting package (includes bolts and pipe plugs).
FM-1-83SS-P	Stainless steel manifold mounting package (includes stainless bolts and brass plugs). Not pictured.
FM-47-0000	Manifold to cylinder head gasket.

Note:

Manifold includes all plugs, gaskets and mounting hardware to head. Risers include plugs, gasket and mounting hardware to mount to manifold.

Universal Atomic 4 Log Style Direct Replacement

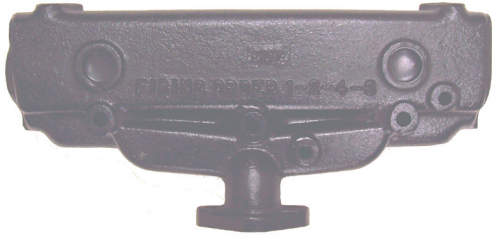

UV 1 259624

UV-1-259624	Water cooled manifold.
UV47-261050	Manifold to cylinder head gasket. Direct replacement for Universal gasket part # 261050.



UV47 261050

Volvo 4 Cylinder Models AQ 115 and AQ 130

Log Style Direct Replacement



VO 1 824532

VO-1-824532	Direct replacement water cooled exhaust manifold. Replaces Volvo part # 824532-6.
VO-20-825599	Direct replacement exhaust elbow. Replaces Volvo part # 825599-4.
VO47-856028	Direct replacement exhaust elbow to manifold gasket. Replaces Volvo part # 856028.



VO 20 825599

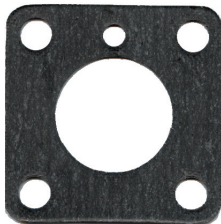

VO47 856028

Barr Marine extends a 1 year warranty on this exhaust manifold.

Volvo 4 Cylinder

Models AQ 120B, 125A, 140A, 145A BB, 140A and 145A
Log Style Direct Replacement



VO 1 855387

VO-1-855387	Direct replacement water cooled exhaust manifold. Replaces Volvo part # 855387-7 and 834438-4.
VO47-855383	Exhaust manifold to cylinder head gasket (requires four gasket per engine).

Note:
Manifold includes all plugs, gaskets and mounting hardware to head.



VO47 855383

Barr Marine extends a 1 year warranty on this exhaust manifold.

Volvo V8-307 and 350 C.I.D.

All Models Center Riser Generic



CHV 1 83

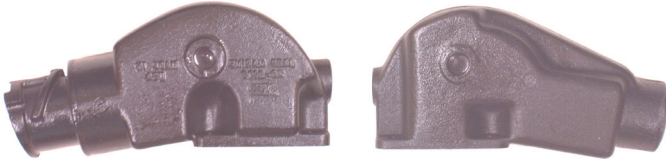

20 0100

20 0082



20 0097



20 0084P

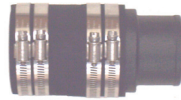

20 0085P



20 0086P



20 0087P



20 0088P



20 0089P



20 0092P



20 0093P



CHV 27 0083



OMC 20 0003



CHV 1 83P



20 0082P

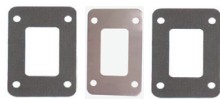

1 0104P

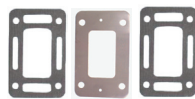

1 0106P



1 0105



1 0107



CHV 47 0000

CHV-1-83	Water cooled center discharge manifold to fit the small block GM engine (3/4" N.P.T. cooling hose connections). All years.
20-0082	Water cooled center discharge riser (3/4" N.P.T. cooling hose connection). Standard for use with 3" I.D. exhaust hose.
20-0100	Water cooled center discharge riser (3/4" N.P.T. cooling hose connection). Standard for use with 4" I.D. exhaust hose.
1-0104P	Adaptor package for fresh water cooled manifold (includes gaskets and block off plate).
1-0105	Center riser manifold-to-riser gasket for fresh water cooling.
1-0106P	Adaptor package for raw water cooling. Used in pre-heating applications (includes gaskets and block off plate with vent hole).
1-0107	Center riser manifold-to-riser gasket (raw water cooling).
20-0082P	Riser mounting package for both 20-0082 and 20-0100.
20-0082SS-P	Stainless steel mounting package (with brass plugs) for both 20-0082 and 20-0100. Not pictured.
20-0084P	Straight exhaust adaptor (includes adaptor, hose and clamps). For use with 3 1/2" I.D. exhaust hose.
20-0085P	Straight exhaust adaptor (includes adaptor, hose and clamps). For use with 2 1/2" I.D. exhaust hose.
20-0086P	90 degree exhaust elbow adaptor for I/O applications (includes adaptor, hose and clamps). For use with 2 1/2" I.D. exhaust hose.
20-0087P	90 degree exhaust elbow adaptor (includes adaptor, hose and clamps). For use with 3" I.D. exhaust hose.
20-0088P	30 degree exhaust elbow adaptor (includes adaptor, hose and clamps). For use with 2 1/2" I.D. exhaust hose.
20-0089P	30 degree exhaust elbow adaptor (includes adaptor, hose and clamps). For use with 3" I.D. exhaust hose.
20-0092P	45 degree exhaust elbow adaptor (includes adaptor, hose and clamps). For use with 3" I.D. exhaust hose.
20-0093P	90 degree exhaust elbow adaptor (includes adaptor, hose and clamps). For use with 3 1/2" or 4" I.D. exhaust hose.
20-0097	3" spacer block (complete with mounting hardware, gasket and 3/4" pipe plug). Capable of stacking.
CHV-1-83P	Manifold mounting package (includes bolts and pipe plugs).
CHV-1-83SS-P	Stainless steel manifold mounting package (includes stainless bolts and brass plugs). Not pictured.
CHV-27-0083	Alternator bracket. Use where engine water pump is mounted on port side of engine below alternator.
CHV-47-0000	Manifold to cylinder head gasket.
OMC-20-0003	Hose bushing 3" to 3 1/2".

Note:

Manifold includes all plugs, gaskets and mounting hardware to head. Risers include plugs, gasket and mounting hardware to mount to manifold.

Volvo V8-307 and 350 C.I.D.

Models AQ 200D, 200F, 225D, 225E, 225F, 255B, 260A, 271A, 280A, 290A
311A BB, 225A, 225 AV, 225B, 260A, 260B and 260C
Center Riser Direct Replacement

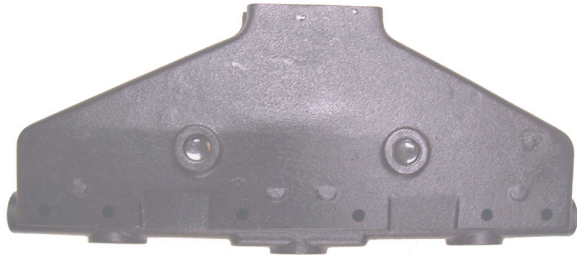

VO 1 835804

VO-1-835804	Direct replacement water cooled exhaust manifold. Replaces Volvo part # 835804-6.
VO-20-855384	Direct replacement exhaust riser/elbow. Replaces Volvo part # 855384-4.
VO-20-855384P	Exhaust riser/elbow mounting package.
VO47-835908	Exhaust riser/elbow to manifold gasket.
VO47-841601	Exhaust manifold to cylinder head gasket

Note:

Manifold includes all plugs, gaskets and mounting hardware to head. Risers include plugs, gasket and mounting hardware to mount to manifold.



VO 20 855384



VO 20 855384P

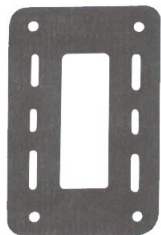

VO47 835908



VO47 841601

Volvo/OMC V8- 5.7 Liter Cobra

Center Riser Direct Replacement



OMC 1 914035

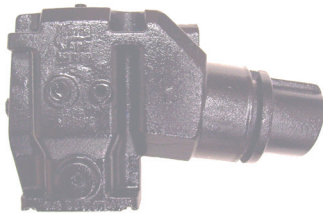

OMC 20 913784

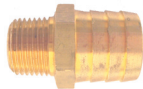

50 512 017



OMC 20 913784P



OMC 1 914035P



OMC47 909314



OMC47 913783

OMC-1-914035	Direct replacement exhaust manifold. Replaces OMC part # 914035 and Volvo part # 3857723 (New Style).
OMC-20-913784	Direct replacement exhaust riser/elbow. Replaces OMC # 913784 and Volvo part # 3863061 (New Style).
OMC-1-914035P	Exhaust manifold mounting package.
OMC-20-913784P	Exhaust riser/elbow mounting package.
OMC47-909314	Exhaust manifold to cylinder head gasket.
OMC47-913783	Direct replacement exhaust riser/elbow to manifold gasket.
50-512-017	Replacement 1/2" N.P.T. to 1" hose (straight)/brass hose fitting.

Note:

Manifold includes all plugs, gaskets and mounting hardware to head. Risers include plugs, gasket and mounting hardware to mount to manifold.

Waukesha V8-302 and 351 C.I.D. All Years

Center Riser Generic

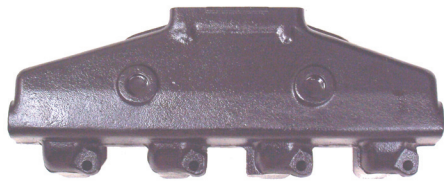

FM 1 83



20 0100

20 0082



20 0097



20 0084P



20 0085P



20 0086P

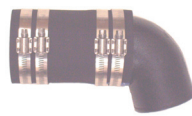

20 0087P



20 0088P



20 0089P



20 0092P



20 0093P



20 0082P



FM 1 83P



1 0104P

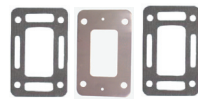

1 0106P



1 0105



1 0107



FM 47 0000

FM-1-83	Water cooled center discharge manifold to fit the small block Ford engine (3/4" N.P.T. cooling hose connections). All years.
20-0082	Water cooled center discharge riser (3/4" N.P.T. cooling hose connection). Standard for use with 3" I.D. exhaust hose.
20-0100	Water cooled center discharge riser (3/4" N.P.T. cooling hose connection). Standard for use with 4" I.D. exhaust hose.
1-0104P	Adaptor package for fresh water cooled manifold (includes gaskets and block off plate).
1-0105	Center riser manifold-to-riser gasket for fresh water cooling.
1-0106P	Adaptor package for raw water cooling. Used in pre-heating applications (includes gaskets and block off plate with vent hole).
1-0107	Center riser manifold-to-riser gasket (raw water cooling).
20-0082P	Riser mounting package for both 20-0082 and 20-0100.
20-0082SS-P	Stainless steel mounting package (with brass plugs) for both 20-0082 and 20-0100. Not pictured.
20-0084P	Straight exhaust adaptor (includes adaptor, hose and clamps). For use with 3 1/2" I.D. exhaust hose.
20-0085P	Straight exhaust adaptor (includes adaptor, hose and clamps). For use with 2 1/2" I.D. exhaust hose.
20-0086P	90 degree exhaust elbow adaptor (includes adaptor, hose and clamps). For use with 2 1/2" I.D. exhaust hose.
20-0087P	90 degree exhaust elbow adaptor (includes adaptor, hose and clamps). For use with 3" I.D. exhaust hose.
20-0088P	30 degree exhaust elbow adaptor (includes adaptor, hose and clamps). For use with 2 1/2" I.D. exhaust hose.
20-0089P	30 degree exhaust elbow adaptor (includes adaptor, hose and clamps). For use with 3" I.D. exhaust hose.
20-0092P	45 degree exhaust elbow adaptor (includes adaptor, hose and clamps). For use with 3" I.D. exhaust hose.
20-0093P	90 degree exhaust elbow adaptor (includes adaptor, hose and clamps). For use with 3 1/2" or 4" I.D. exhaust hose.
20-0097	3" spacer block (complete with mounting hardware, gasket and 3/4" pipe plug). Capable of stacking.
FM-1-83P	Manifold mounting package (includes bolts and pipe plugs).
FM-1-83SS-P	Stainless steel manifold mounting package (includes stainless bolts and brass plugs). Not pictured.
FM-47-0000	Manifold to cylinder head gasket.

Note:

Manifold includes all plugs, gaskets and mounting hardware to head. Risers include plugs, gasket and mounting hardware to mount to manifold.

Center Discharge Exhaust Riser 4"

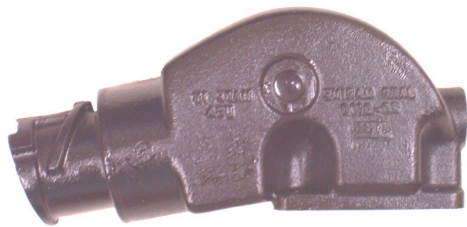

20 0100



20 0082P

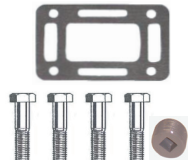

20 0082SS P

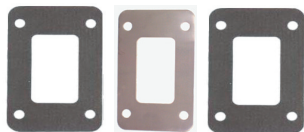

1 0104P

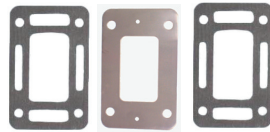

1 0106P

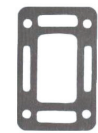

1 0107

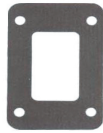

1 0105

20-0100	Water cooled center discharge riser (3/4" N.P.T. cooling hose connection). Standard for use with 4" I.D. exhaust hose.
1-0104P	Adaptor package for fresh water cooled manifold (includes gaskets and block off plate).
1-0105	Center riser manifold-to-riser gasket for fresh water cooling.
1-0106P	Adaptor package for raw water cooling. Used in pre-heating applications (includes gaskets and block off plate with vent hole).
1-0107	Center riser manifold-to-riser gasket (raw water cooling).
20-0082P	Riser mounting package for both 20-0082 and 20-0100.
20-0082SS-P	Stainless steel mounting package (with brass plugs) for both 20-0082 and 20-0100.

The Barr Center Riser is designed to limit back pressure on the engine. This riser is to be utilized with the Barr CHV-1-83, FM-1-83 and CHVA-1-84 manifolds!

*Note:
Riser includes plug, gasket and mounting hardware to mount to manifold.*

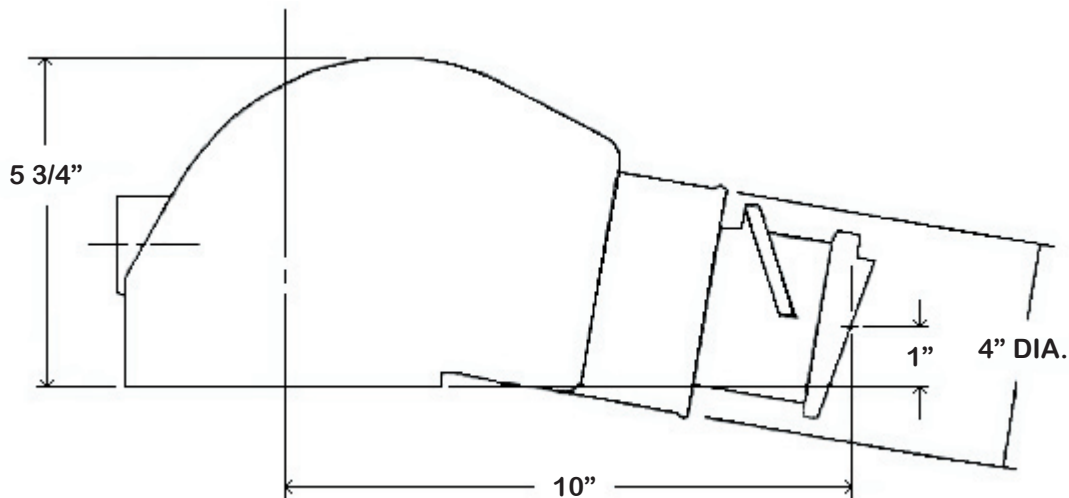

Center Discharge Manifold and Riser System Dimensions

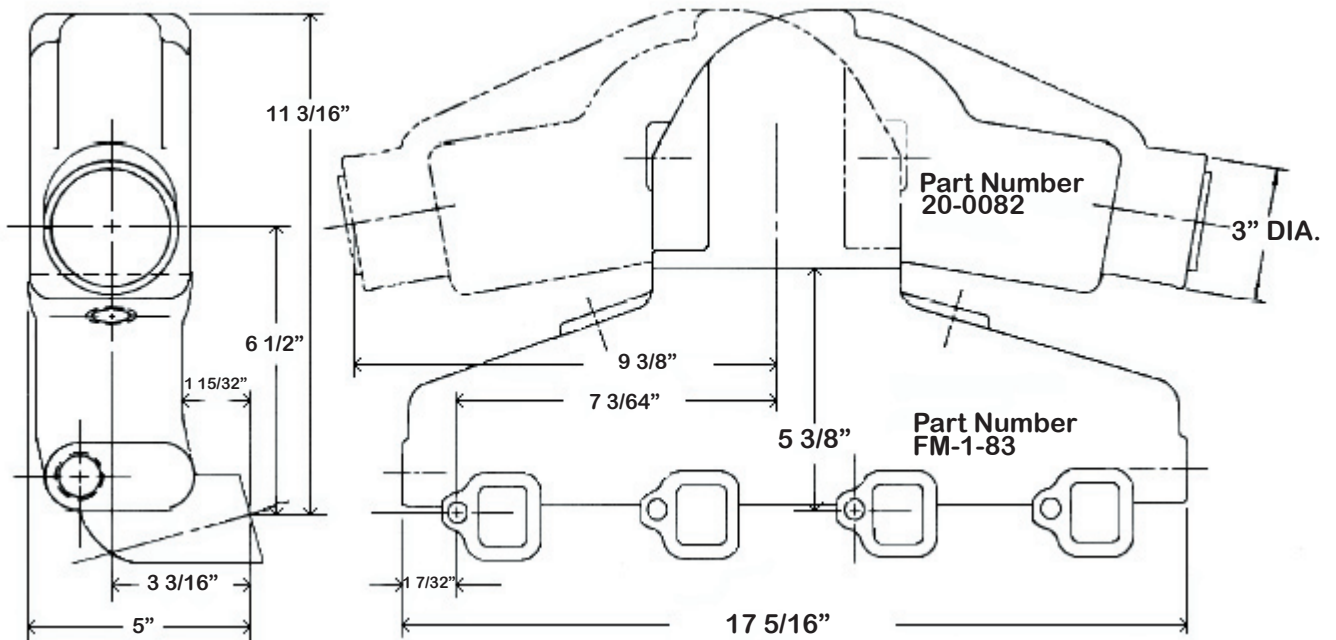
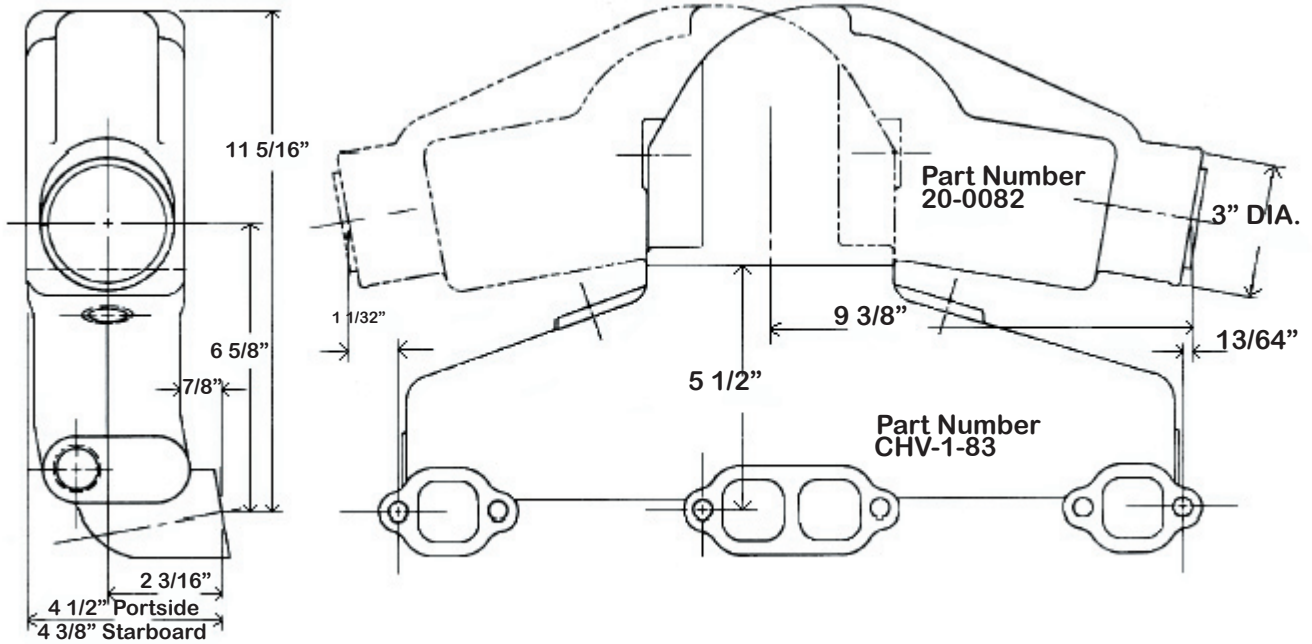

Center Discharge Manifold and Riser System Dimensions

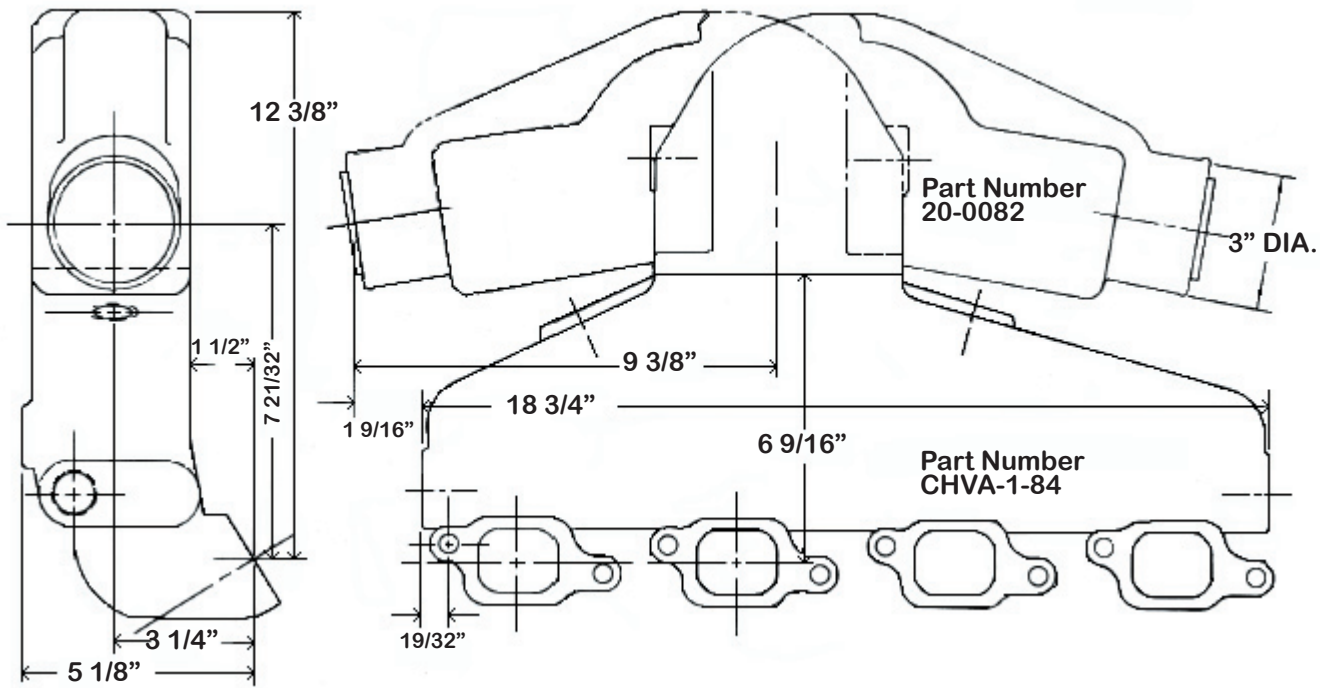

Exhaust Risers and Connectors

Part#	Detailed Description
1-0001	AdaptorAdaptor for Barr manifold replacing size "A" end plate (2" pipe). Order (1) for 4 or 6 cylinder engines or (2) for V8 cylinder engines.
1-0081	Adaptor for Barr round-type Oldsmobile conversion manifold (OR-1-73). Order (2) for Oldsmobile V8 cylinder engines.
1-0012L	Adaptor for Chris Craft V8 283 C.I.D. manifolds prior to Models F, G, K and Q (three pass system), "L" for left side. Order (1) for Chris Craft V8 cylinder engines (port/left side).
1-0012R	Adaptor for Chris Craft V8 283 C.I.D. manifolds prior to Models F, G, K and Q (three pass system), "R" for right side. Order (1) for Chris Craft V8 cylinder engines (starboard/right side).
1-0283A	Adaptor for Chris Craft V8 283, 302, 305, 307, 327 and 350 C.I.D. manifolds; models F, G and K (two pass system). Order 2 for Chris Craft V8 cylinder engines.
1-0283L	Adaptor for Chris Craft V8 283, 302, 305, 307, 327 and 350 C.I.D. manifolds; model Q (single pass system), "L" for left side. Order (1) for Chris Craft V8 cylinder engines (port/left side).
1-0283R	Adaptor for Chris Craft V8 283, 302, 305, 307, 327 and 350 C.I.D. manifolds; model Q (single pass system), "R" for right side. Order (1) for Chris Craft V8 cylinder engines (starboard/right side).
1-0007	Adaptor for Chrysler V8 383, 413 and 440 C.I.D. manifolds (4 bolt), Chrysler Ace and Crown Engines. Order (1) for Ace and Crown 6 cylinder engines and (2) for Chrysler V8 engines.
1-0013L	Adaptor for Chrysler V8 318 C.I.D. (prior to 1966); "L" for left side. Order (1) for Chrysler V8 engines (port/left side).
1-0013R	Adaptor for Chrysler V8 318 C.I.D. (prior to 1966); "R" for right side. Order (1) for Chrysler V8 engines (port/left side).
1-0071	Adaptor for Chrysler V8, Model M 81 (225 H.P.). Order (2) for Chrysler M 81 V8 engines.
CM-1-6672C	Adaptor for Chrysler V8 318 C.I.D. (after 1966). Order (2) for Chrysler V8 engines.
1-0002	Adaptor for Graymarine V8 327 C.I.D. (4 bolt flange). Order (2) for Graymarine V8 (4 bolt) engines.
1-0069	Adaptor for Graymarine V8 327 C.I.D. (3 bolt flange). Order (2) for Graymarine V8 (3 bolt) engines.
1-0070	Adaptor for Palmer V8, Model 14-345
1-0014	Universal adaptor to fit any engine with 3 1/4" or smaller manifold end (drill to suit manifold). Order (1) for 4 or 6 cylinder engines or (2) for V8 cylinder engines.
20-0008	Adaptor for 2" standard N.P.T. pipe thread. Order (1) for 4 or 6 cylinder engines or (2) for V8 cylinder engines.
20-0004	Adaptor for 2 1/2" standard N.P.T. pipe thread. Order (1) for 4 or 6 cylinder engines or (2) for V8 cylinder engines.

Exhaust Risers and Connectors



20 0000



20 0031



20 0055



20 0039



20 0035



20 0034



20 0002P

20-0000	Swivel-type high discharge exhaust riser; 8 1/2" riser protection. Requires (1) mounting hardware kit #20-0002P per riser. Use only with 2 7/8" to 3" I.D. exhaust hose.
20-0002P	Mounting hardware kit.
20-0031	Swivel-type 90 degree exhaust elbow connector with internal water discharge. Accepts 2 1/2" to 3" I.D. exhaust hose. Requires (1) mounting hardware kit #20-0002P per elbow.
20-0034 or 20-0035	Exhaust connector #20-0035 (for 2 1/2" I.D. exhaust hose) or exhaust connector #20-0034 (for 3" I.D. exhaust hose). Connects to #20-0039 using (1) #20-0002P per connector.
20-0039	Fully jacketed swivel-type exhaust riser; 7" riser protection. Requires (2) mounting hardware kits #20-0002P ((1) kit to mount riser to manifold and (1) kit to mount elbows #20-0034 or #20-0035 to riser).
20-0055	Swivel-type 30 degree exhaust elbow connector; fully jacketed. Accepts 2 1/2" or 3" I.D. exhaust hose. Requires (1) mounting hardware kit #20-0002P per elbow.

Note:

A header adaptor style end cap must be installed on the exhaust end of the log manifold in order to mount these risers or elbows. See the "Manifold End Plate and Gasket Identification Listing" page at the beginning of this catalog for the proper end plates specific to your application.

Exhaust Risers and Connectors

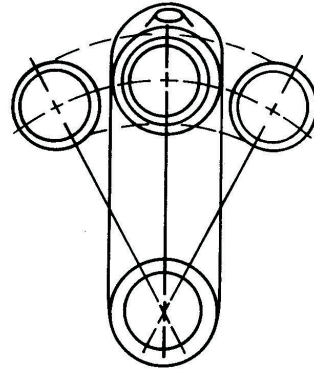
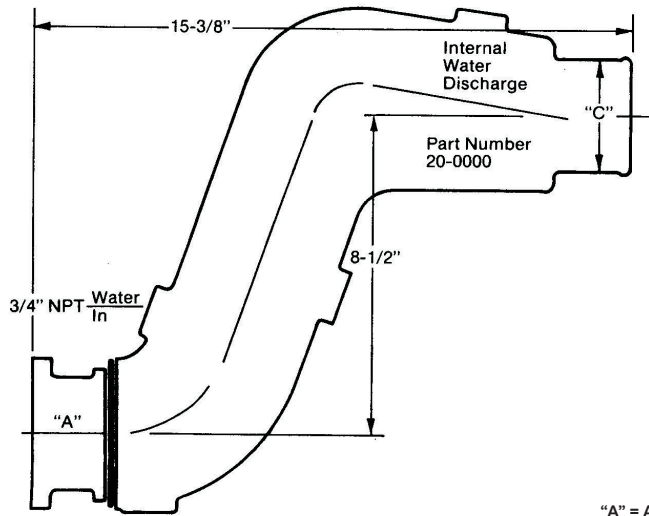
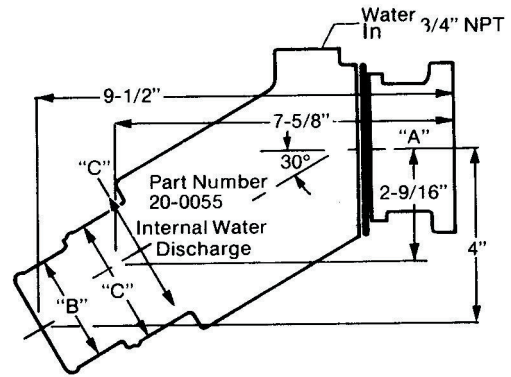
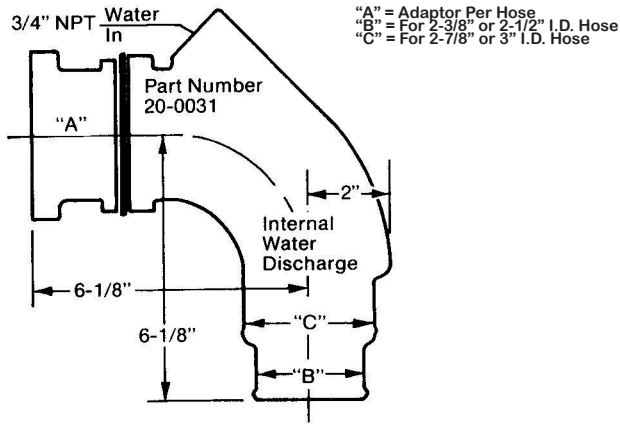

"A" = Adaptor Per Hose
"B" = For 2-3/8" or 2-1/2" I.D. Hose
"C" = For 2-7/8" or 3" I.D. Hose

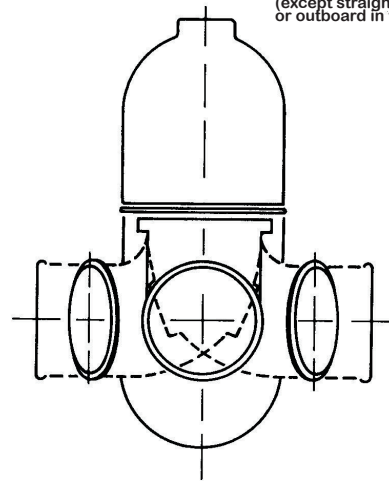
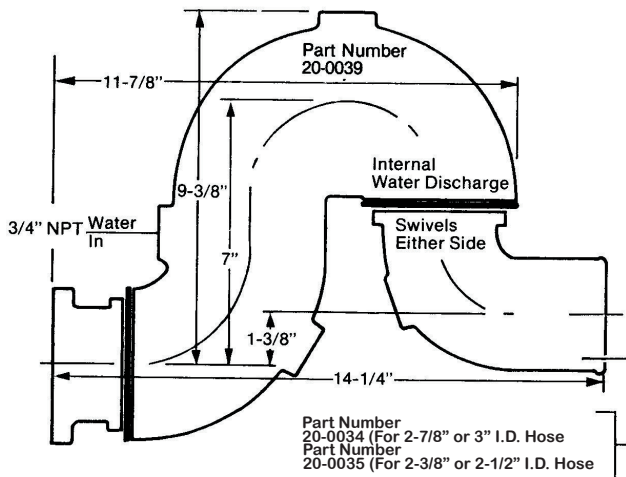

All Barr exhaust risers and connectors (except straight) can be swiveled inboard or outboard in vertical plane.

Exhaust connectors 20-0034 and 20-0035 can be swiveled inboard or outboard in horizontal plane.

Thermostat and Thermostat Housing Assemblies Barr Marine Style



CHV 29 0120



CHV 29 80



CHVA 29 78



FM 29 0083



OR 29 74



CM 29 3675303

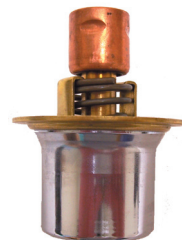

CM 29 4142522



CR 29 96319



MC 29 59078



MC 29 59137



OMC 29 383307

CHV-29-0120	Thermostat housing assembly for dual pump cooling system on 4 cyl. Chevrolet engines.
CHV-29-80	Thermostat housing assembly for dual pump cooling system on Chevrolet V6 and Small Block V8 engines.
CHVA-29-78	Thermostat housing assembly for dual pump cooling system on Big Block Chevrolet V8's.
CM-29-3675303	Chrysler thermostat (140 degree).
CM-29-4142522	Chrysler thermostat (163 degree).
CR-29-96319	Crusader thermostat (143 degree).
FM-29-0083	Thermostat housing assembly for dual pump system on Small Block Ford V8's.
MC-29-59078	MerCruiser thermostat for models 120, 140, 120R/140R, 160, 165 and 200.
MC-29-59137	MerCruiser thermostat for models 888 (Ford), 225 (Ford), 233 (Ford) and 255 (Ford).
OMC-29-383307	OMC thermostat (160 degree).
OR-29-74	Thermostat housing assembly for dual pump cooling system on Oldsmobile V8's (350, 403 and 455 C.I.D.).

Adaptor Bell Housings



CHV-24-0001



CHV-WVDC-5561A



CHVA-WVDC-77A



FM-WVDC-70A



HUR-SAE4



MC-24-14043

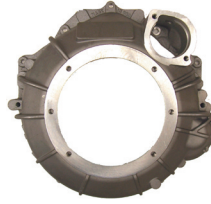

MC-24-44187



OR-WVDC-65A

Not Pictured/Call
SAE3-WVDC

Not Pictured/Call
SAE2 502



OR-WVDC-73A



OR-WVDC-76A

Not Pictured/Call
CHV-WVDC-70A

Not Pictured/Call
MC-24-0001

Not Pictured/Call
OR-WVDC-78A

Part#	Detailed Description
CHV-24-0001	Chevrolet in-line 6 cylinder 1962-79; 194, 230 and 250 C.I.D.; all models with 12 5/8" diameter flywheel. Also for 1963-283, 307, 327 and 350 C.I.D. with 12 5/8" diameter flywheel (26 spline applications).
CHV-WVDC-5561A	Chevrolet V8 OHV 1955-62; 265, 283 and 327 C.I.D.; 1963 to date, 292 C.I.D. with 14" flywheel and starter mounting to flywheel housing; 1959-70; 348, 396, 409, 427 and 454 C.I.D. with 14" diameter flywheel (26 spline applications).
CHV-WVDC-70A	Chevrolet V8 OHV 1971 to date; all models with 14" diameter flywheel and starter mounting to the underside of block (26 spline applications).
CHVA-WVDC-77A	Chevrolet V8 OHV 1971 to date; all models with 14" flywheel and top mounted starter (26 spline applications).
FM-WVDC-70A	Ford and Mercury in-line 6 cylinder 1965-69; 240 and 300 C.I.D. Ford and Mercury V8 OHV 1965 to date; 289, 302 and 351 C.I.D. (identified by the use of 6 bolts to attach flywheel housing to cylinder block-26 spline applications).
HUR-SAE4	Kubota Diesel 1902 Series; flywheel housing for Hurth HBW-50, 100 and 150-2R gear (2:1 ratio).
MC-24-0001	Starter cover plate for use on housings (MC-24-44187) utilizing bottom mounted starters (26 spline applications).
MC-24-14043	Dust cover plate used on MerCruiser style flywheel housing (MC-24-44187)(26 spline transmissions).
MC-24-44187	Direct replacement for MerCruiser part # 44187. Fits Chevrolet in-line 6 cylinder 250 and 292 C.I.D. with 14" flywheel, Chevrolet V6 200, 201, 229 and 262 C.I.D. with 14" flywheel, Chevrolet V8 (Small Block) 265, 283, 305, 307, 327 and 350 C.I.D. with 14" flywheel and Chevrolet V8 (Big Block) 348, 396, 409, 427 and 454 C.I.D. with 14" flywheel (26 spline applications).
OR-WVDC-65A	Buick V8 1967-75; 400, 430 and 455 C.I.D., Oldsmobile V8 1964-84; 330, 350, 400, 403, 425 and 455 C.I.D. and Pontiac V8 1965-78; 326, 350, 389, 400, 428 and 455 C.I.D. (26 spline applications).
OR-WVDC-73A	All above Pontiac, Olds and Buick models with use of top mounted starter. Requires separate rear motor supports which mount to transmission. Order part # AS1-9 for centerline mounting; 9-0003 for 3" offset above centerline mounting and 9-0004 for 6" (26 spline applications).
OR-WVDC-76A	All above Pontiac, Olds and Buick models with use of top mounted starter. Requires separate rear motor supports which mount to transmission. Order part # AS1-9 for centerline mounting; 9-0003 for 3" offset above centerline mounting and 9-0004 for 6" (26 spline applications). Rear engine mounts are incorporated into housing for top mounted starter.
OR-WVDC-78A	Buick V8 1967-75; 400, 430 and 455 C.I.D., Oldsmobile V8 1964-84; 330, 350, 400, 403, 425 and 455 C.I.D. and Pontiac V8 1965-78; 326, 350, 389, 400, 428 and 455 C.I.D. (26 spline applications). Except not equipped with rear engine mount.
SAE3-WVDC	Caterpillar 3100 and 3200 Series 636 C.I.D.; Adapts SAE # 3 pattern to Warner "Velvet Drive" transmission (26 Spline applications).
SAE2-502	Twin Disc SAE pattern; adapts SAE # 2 pattern to Twin Disc 502 transmission.

Rubber Engine Mounts

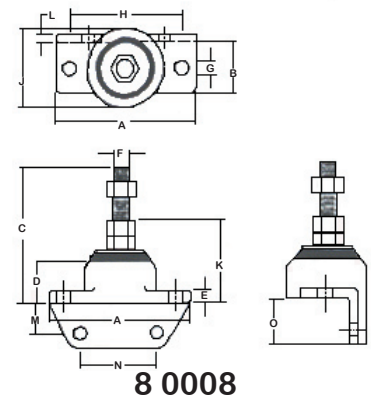
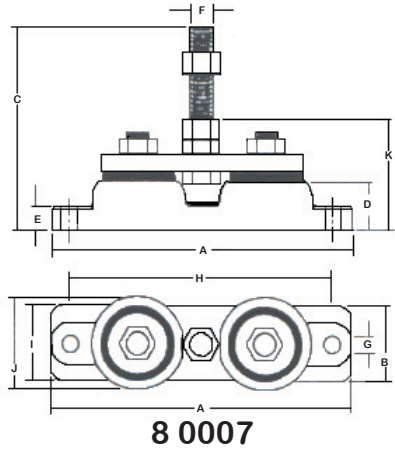
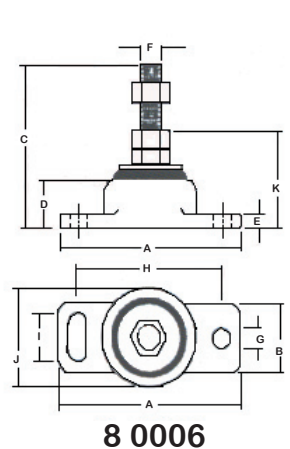
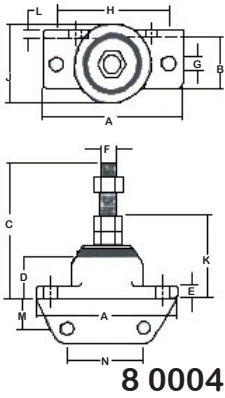
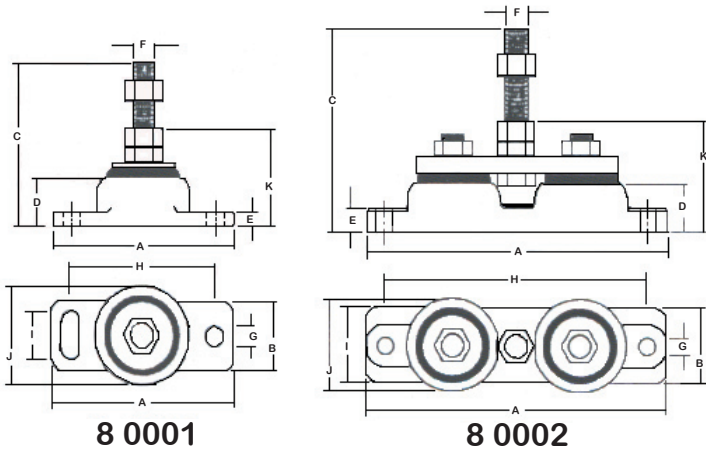

8-0001	Rubber engine mount; single. Adjustable both vertically and horizontally to facilitate engine-propeller shaft alignment. Each mount has a capacity of 350 lbs. The rubber cushions are locked to the base and are oil and fuel resistant.
8-0002	Rubber engine mount; double. Increased capacity for Diesel and extra heavy-duty applications. The rubber cushions are locked to the base, not vulcanized and can be replaced. This mount is vertically adjustable to facilitate engine alignment. Each mount has a capacity of 350 lbs.
8-0004	Rubber engine mount; single. This mount retains all of the fine features of the 8-0001 augmented by an additional tie-down area to bolt to the stringer pads. Each mount has a capacity of 350 lbs.
8-0006	Rubber engine mount; single. Adjustable both vertically and horizontally to facilitate engine-propeller shaft alignment. Each mount has a capacity of 350 lbs. The rubber cushions are locked to the base and are oil and fuel resistant.
8-0007	Rubber engine mount; double. Increased capacity for Diesel and extra heavy-duty applications. The rubber cushions are locked to the base, not vulcanized and can be replaced. This mount is vertically adjustable to facilitate engine alignment. Each mount has a capacity of 550 lbs.
8-0008	Rubber engine mount; single. This mount retains all of the fine features of the 8-0006 augmented by an additional tie-down area to bolt to the stringer pads. Each mount has a capacity of 350 lbs.

Specifications For Rubber Engine Mounts

Part #	A	B	C	D	E	F Bolt Size & Thread	G Hold Down Bolt Size	H	I	J	K	L	M	N	O	Max Rated Load Per Mount In Lbs.	Deflection at Avg. Rated Load In Ins.	Packaged Weight In Lbs.
8-0001	5	1 3/4	4 1/2	1 5/16	5/8	5/8 - 18UNF	7/16	4	1 3/16	2 1/2	2 11/16	N/A	N/A	N/A	N/A	350	0.060	3
8-0002	8 1/4	2	5 5/8	1 5/16	5/8	5/8 - 18UNF	7/16	7 1/4	N/A	2 1/2	3 1/8	N/A	N/A	N/A	N/A	550	0.060	5
8-0004	5	1 3/4	4 1/2	1 5/16	5/8	5/8 - 18UNF	7/16	4	N/A	2 3/4	2 11/16	1/4	1	2 3/4	1 1/2	350	0.060	3.5
8-0006	5	1 3/4	4 1/2	1 5/16	5/8	3/4 - 16UNF	7/16	4	1 3/16	2 1/2	2 11/16	N/A	N/A	N/A	N/A	350	0.060	3
8-0007	8 1/4	2	5 5/8	1 5/16	5/8	3/4 - 16UNF	7/16	7 1/4	N/A	2 1/2	N/A	N/A	N/A	N/A	N/A	550	0.060	5
8-0008	5	1 3/4	4 1/2	1 5/16	5/8	3/4 - 16UNF	7/16	4	N/A	2 3/4	2 11/16	1/4	1	2 3/4	1 1/2	350	0.060	3



Torsional Dampers

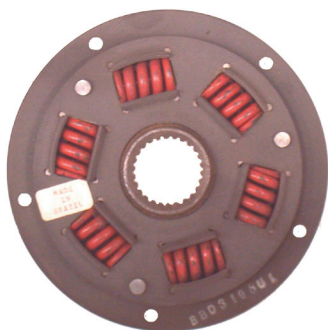

AS4 K1C

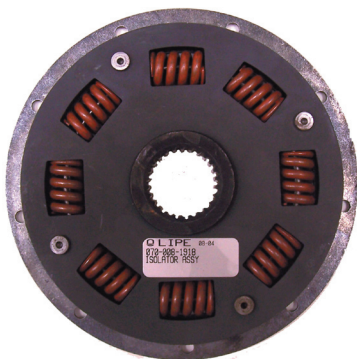

AS7 K1C

AS3-K2C	Heavy duty damper for diesel applications up to 15" diameter for 26 spline transmissions. Not pictured.
AS4-K1C	6.50" diameter damper (5.593" bolt circle diameter) for 26 spline transmissions as used on flywheel forward Flagship and Chris Craft installations. Replaces Chris Craft part # 16.99-08334.
AS4-K2C	Three-legged damper for 26 spline transmissions and flywheel diameters more than 13.32". For V8 engines up to 350 C.I.D.
AS5-K2C	Full circle damper 13.25" diameter for 26 spline transmissions. For engines up to 370 C.I.D. Not pictured.
AS7-K1C	7.12" diameter damper (6.58" bolt circle diameter) for 26 transmissions
AS7-K2C	Full circle damper 13.25" diameter for 26 spline transmissions. For engines up to 454 C.I.D.
AS8-K2C	Three-legged damper for 26 spline transmissions and flywheel diameters less than 13.32". For V8 engines up to 350 C.I.D.
1004-65-0001	Full circle damper 13.87" diameter for 26 spline transmissions (use on CAT 3208's and Detroit Diesel 6-71's). Not pictured.

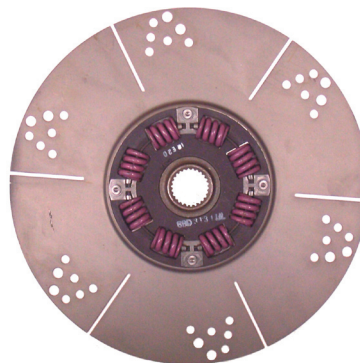

AS7 K2C

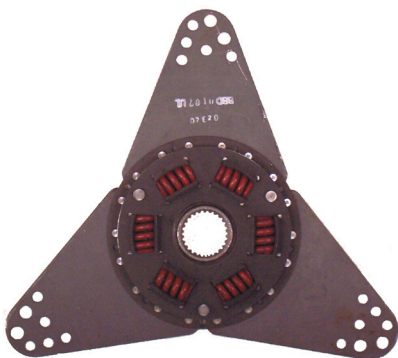

AS4 K2C

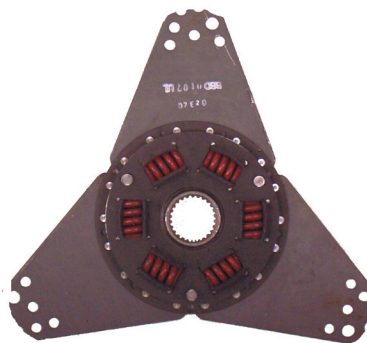

AS8 K2C

Flame Arrestors



CAO 10 59

CAO-10-59	Flame arrestor; throat diameter-4 1/4" and height-2 1/8".
CHV-10-56	Flame arrestor; throat diameter-2 5/8" and height-1 7/8".
LEM-10-58	Flame arrestor; throat diameter-5 1/8" and height-3 1/4".
OR-10-61	Flame arrestor; throat diameter-3 1/8" and height-1 7/8".
OR-10-66	Flame arrestor; throat diameter-5 1/8" and height-2 1/4".

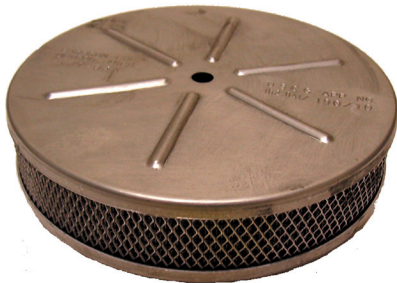

CHV 10 56



OR 10 61



LEM 10 58



OR 10 66

Crossover Reference Guide

CHRIS CRAFT TO BARR

CHRIS CRAFT PART #	BARR PART #
16.20-07593	CC 20 07593
16.20-07605	CC 20 07605
16.20-07686	CC 1 07686
16.20-08288	CC 20 08288
16.20-08289	CC 20 08289
16.50-05944	CC47 1650 05944
16.50-06022	CC47 1650 06022
16.50-07290	CC47 1650 07290
16.50-07596	CC47 1650 07596
16.50-07597	CC47 1650 07597
16.50-07681	CC47 1650 07681

CHRYSLER TO BARR

CHRYSLER PART #	BARR PART #
2469556	CM 1 6672A
2469639	CM 20 2847405
2600402	CM 20 2600402
2846106	CM 1 6672B
2846689	CM 20 6674
2847404	CM 20 4142411
2847405	CM 20 2847405
2847623	CM 20 4142411
3527781	CM 1 6672E
3527794	CM 20 6672
3619659	CM 1 5972A
3675826	CM 1 6677A
3745639	CM 20 4142411
4142322	CM 1 6677A
4417063	CM 1 4417063
E7081M	CM 1 5972A
E9232M	CM 20 9232
E9233M	CM 20 4142411

CRUSADER TO BARR

CRUSADER PART #	BARR PART #
20471	CR 50 20471
22032	CR 50 22032
22033	CR 50 22033
96108	CR47 C 96108
96120	CR 1 97752
96121	CR 1 97753
96306	CHV 47 0000
96369	CR 50 96369
96560	CR 20 96560
96562	CR47 C 96562
96653	CHVA 47 0000
97169	CR 20 97169
97387	CR 20 97387
97624	CR 20 97624
97752	CR 1 97752
97753	CR 1 97753

CRUSADER TO BARR (CONTINUED)

CRUSADER PART #	BARR PART #
97772	CR 20 97772
97924	CR 20 97924
97992	CR 1 97992
97993	CR 1 97993
98068	CR 20 98068
98126	CR 20 98126
98243	CR 1 98243

MARINE POWER TO BARR

MARINE POWER PART #	BARR PART #
0000-815H7	50 525 020
0991-110	CHVA 1 84
0991-600	CHVA 47 0000
0992-000	20 0082
0992-001	1 0106P
0992-300	1 0104P
0992-400	MC 20 44354
0992-593	20 0100
0994-000	CHV 1 83
0994-600	CHV 47 0000

MERCUISER TO BARR

MERC. PART #	BARR PART #
97429	MC 29 97429
12076A2	MC 20 12076
47441A1	MC 29 47441
47442A1	MC 20 47442
47638A1	1 47638
47735A17	MC 1 47735
47736A17	MC 1 47736
47737A10	MC 1 47737
47738A10	MC 1 47738
55538A2	MC 20 55538
58759A14	MC 1 58759
59498A1	MC 29 59498
60252A2	1 60252
60783A3	MC 29 60783
61851A3	MC 20 61851A2
62898A1	MC 29 62898
63122A13	MC 1 63122
63588A1	MC 29 63588
65603A13	MC 1 65603
65604A12	MC 1 65604
72963A9	MC 20 72963
73811A1	1 73811
73813A1	1 54870
73813A1	1 73813
76325A9	MC 20 76325
76351A2	MC 20 60426
76351A2	MC 20 76351
76668A3	MC 20 76668

Crossover Reference Guide

MERCUISER TO BARR (CONTINUED)

MERC. PART #	BARR PART #
76771A3	MC 20 76771
77234A7	MC 1 77234
77235A8	MC 1 77235
78984A1	MC 29 78984
78985A1	MC 29 78985
806867A8	MC 1 99798
807078A6	MC 1 89011
807476A6	MC 20 93320A3
807477A5	MC 20 93322A3
807988A2	MC 20 44354
860246A10	MC 1 87114
861493A3	MC 29 47587
861493A3	MC 29 60372
87290A4	MC 29 87290
90736A18	MC 29 90736
90880A2	MC 20 90880
95862A5	MC 1 95862
96705A1	MC 1 52390
96705A10	MC 1 96705
97428T 2	MC 29 97428
98502A2	MC 20 98502
98504A3	MC 20 98504
99746A17	MC 1 99746
NLA	MC 20 61811A4
NLA	MC 29 79468
1623-8951A37	MC51 1623 8951A27

OMC TO BARR

OMC PART #	BARR PART#
311550	1 910280
312148	1 312148
312149	1 312149
314810	OMC 29 982201
384560	OMC 24 0000
385799	OMC 20 910380
907776	OMC 20 981281
907777	OMC 20 981281
907885	1 907885
908719	1 908719
909280	OMC 1 912441
910144	OMC 1 912442
910280	1 910280
910380	OMC 20 910380
910384	1 910384
912441	OMC 1 912441
912442	OMC 1 912442
913784	OMC 20 913784
914035	OMC 1 914035
979729	OMC 1 981462
979730	OMC 20 980536

OMC TO BARR (CONTINUED)

OMC PART #	BARR PART#
979758	OMC 1 979758
979759	OMC 1 979759
979760	OMC 1 979760
979761	OMC 1 979761
980083	OMC 1 984054
980188	OMC 20 910380
980382	OMC 24 0000
980459	OMC 1 981462
980460	OMC 1 984054
980536	OMC 20 980636
980572	OMC 1 980959
980617	OMC 20 980617
980957	OMC 1 984054
980959	OMC 1 980959
981281	OMC 20 981281
982490	OMC 1 984054
982680	OMC 20 982680

OSCO TO BARR

OSCO#	EDM PART#
106	CM 1 6672B
121	CM 1 5972C
150	CM 1 5972B
424	CM 1 5972D
557	CM 1 6672E
639	CM 20 2847405
689	CM 20 6674
794	CM 20 6672
826	CM 1 6677A
992	20 0082
994	CHV 1 83
2018	20 0102
2076	MC 20 12076
2441	OMC 1 912441
2442	OMC 1 912442
4354	MC 20 44354
5538	MC 20 55538
5603	MC 1 65603
5604	MC 1 65604
5639	CM 20 4142411
5805	VO 1 835804
5862	MC 1 95862
6022	CC47 1650 06022
6108	CR47 C 96108
6325	MC 20 76325
6351	MC 20 76351
6562	CR47 C 96562
6705	MC 1 96705
6771	MC 20 76771
7056	CC 1 07686

Crossover Reference Guide

OSCO TO BARR (CONTINUED)

OSCO PART #	BARR PART #
7081	CM 1 5972A
7169	CR 20 97169
7296	CR 20 97296
7387	CR 20 97387
7624	CR 20 97624
7752	CR 1 97752
7753	CR 1 97753
7772	CR 20 97772
7924	CR 20 97924
7992	CR 1 97992
7993	CR 1 97993
8068	CR 20 98068
8243	CR 1 98243
8759	MC 1 58759
9011	MC 1 89011
9234	CM 20 9234
9745	MC 1 99746
9798	MC 1 99798
41812	MC47 27 41812
47510	MC47 27 47510
48818	MC47 27 48818
50456	OMC 20 913784
52076	MC47 27 52076
MC553-BB	MC 29 78985
54870	1 54870
56879	VO 20 855384
60252	1 60252
99204	20 0100
0188	OMC 20 910380
0402	CM 20 2600402
05944	CC47 1650 05944
0879	MC 20 90880
106-T	CM 1 6672H
143-DEG	MC 29 59137
1851(SINGLE)	MC 20 61851A2
3320(SINGLE)	MC 20 93320A3
3322(SINGLE)	MC 20 93322A3
480-MK	CM 20 6672P
480-MK	CM 20 6674P
480-MK-FW	CM 20 6672J P
480-MK-FW	CM 20 6674J P
7081-GH	CM 1 5972P
7087-MK	CM 20 9232P
7087-OR	CM 20 9225/6
7114B2	MC 1 87114
7234B	MC 1 77234
7235B	MC 1 77235
826GH	CM 1 6672P
826-MK-SS	CM 1 6677 SS P
8503A	MC 20 98504
8503-G0	MC47 27 87105

OSCO TO BARR (CONTINUED)

OSCO PART #	BARR PART #
8503-GB	MC47 27 41811
8503-GR	MC47 27 41813
9863-T	OMC 20 982680
992-G	1 0107
992-G-FW	1 0105
992MK	20 0082P
994-S3	20 0097
BG	1 0019
CV-GH	CHV 47 0000
CW994	CHVA 1 84
CW-GH	CHVA 47 0000
CY4 GH	CHV 47 0120
CY-MG	MC 1 6364G
F66CS	50 512 019
F68C9	50 525 020
F68CS	50 512 020
FL994	FM 1 83
MC552-BB	MC 29 90736
MC552-SB	MC 29 87290
MC553-SB	MC 29 78984
MC55-TBB	MC 29 47442
MC55-TSB	MC 29 47441
V0418	VO 1 855387

SIERRA TO BARR

SIERRA PART #	BARR PART #
18-0113	MC47 27 97542
18-0114	OMC47 907761
18-0183	MC47 27 73866
18-0332	MC47 27 35898
18-0335	MC47 27 39947
18-0353	MC47 27 58764
18-0356	MC47 27 64692
18-0364	MC47 27 73812
18-0418	MC47 27 46820
18-0672	MC47 27 41811
18-0872	MC47 27 33395
18-0885	MC47 27 48042
18-0897	MC47 27 41813
18-0903	MC47 27 49110
18-0928	MC47 27 73814
18-0943	OMC47 909786
18-0954	MC47 27 92720
18-0992	MC47 27 68715
18-1203	MC47 27 53354
18-1204	MC47 27 96429
18-1209	MC47 27 39917
18-1210	MC47 27 39923
18-1902	OMC 1 912441
18-1903	OMC 1 912442

Crossover Reference Guide

SIERRA TO BARR (CONTINUED)

SIERRA PART #	BARR PART #
18-1904	OMC 1 980959
18-1916	CR 20 97169
18-1919	CR 20 97387
18-1921	OMC 20 982680
18-1922	OMC 20 910380
18-1924	CR 20 97624
18-1927	CR 20 97772
18-1929	CR 1 97992
18-1930-1	VO 1 855387
18-1931-1	VO 1 835804
18-1933	CR 1 97993
18-1935-1	VO 20 855384
18-1940	CM 1 6677A
18-1941	CM 1 6672B
18-1945	CM 20 6674
18-1946	CM 20 6672
18-1950-1	MC 1 77234
18-1951-1	MC 1 77235
18-1952-1	MC 1 99746
18-1953	MC 1 87114
18-1954	MC 1 95862
18-1955	MC 1 96705
18-1956-1	MC 1 99798
18-1957	MC 1 89011
18-1958	MC 1 65604
18-1959	MC 1 63122
18-1960-1	MC 1 58759
18-1961	MC 1 52390
18-1962	MC 1 65603
18-1968	MC 29 47587
18-1969	MC 29 60372
18-1970-1	MC 20 98504
18-1971	MC 20 76351
18-1972	MC 20 76325
18-1973	MC 20 55538
18-1974-1	MC 20 98502
18-1975	MC 20 12076
18-1976-1	MC 20 44354
18-1977	MC 29 47441
18-1978	MC 20 76771
18-1983	CR 1 98243
18-1990	1 73813
18-1991	20 0089P
18-1992-1	20 0087P
18-1993	MC 29 78984
18-1994	MC 29 87290
18-1995	1 47368
18-1997-1	CHV 1 83
18-1998-1	FM 1 83
18-1999	20 0082
18-2104	MC 51 75832

SIERRA TO BARR (CONTINUED)

SIERRA PART #	BARR PART #
18-2146	MC 51 59830
18-2554	MC47 27 41812
18-2819	MC47 27 39915
18-2830	MC47 27 46401
18-2831	MC47 27 47590
18-2832	MC47 27 48043
18-2833	MC47 27 99777
18-2844	MC47 27 48818
18-2849	MC47 27 87105
18-2850	OMC47 908935
18-2854	1 0107
18-2859	OMC47 311131
18-2860	OMC47 311130
18-2861	OMC47 311121
18-2875	OMC47 908013
18-2883	OMC47 907775
18-2896	MC47 27 52546
18-2743	MC47 27 94996
18-2820	MC47 27 64818
18-2902	MC47 27 33395
18-2909	MC47 27 97757
18-2917	MC47 27 53045
18-2941	CM 1 6672D
18-2949	CHV47 0000
18-2971	VO47 835908
18-4008	MC 20 60207
18-4009	1 60252
18-4360	CM 1 6672B P
18-4363	FM 1 83P
18-4364	20 0082P
18-4367	MC47 27
18-4394	99777A1
18-4395	MC47 27
18-4396	33395A1
18-4397	MC47 27
18-4398	35898A4
18-4399	MC47 27
18-4461	46401A1

VOLVO TO BARR

VOLVO PART #	BARR PART #
824532-6	VO 1 824532
825599-4	VO 20 825599
834438-4	VO 1 855387
835804-6	VO 1 835804
855384-4	VO 20 855384
855387-7	VO 1 855387
856883-4	VO 1 835804
3857723	OMC 1 914034
3863031	OMC 20 913784

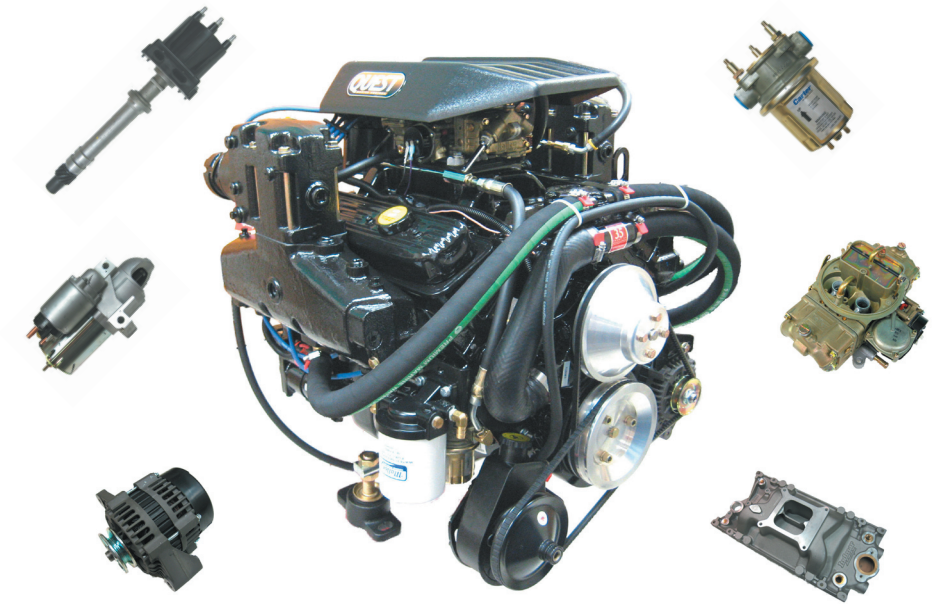

Barr Marine By EDM
P.O. Box 190
100 Douglas Way
Natural Bridge Station, VA. 24579

Toll Free 1-866-255-9265

Ph: 1-540-291-4180

Fax: 1-540-291-4185

E-Mail: sales@barrmarine.net

www.barrmarine.net

**EVERYTHING A MARINE ENGINE
SHOULD BE
ONLY BETTER!!**

Fine Engine and Engine Parts Manufactured and Supplied by

BARR
MARINE BY EDM



It's The Law - Know Your Rights!

Consumers are protected from manufacturers who attempt to unfairly chain the purchasers of their products to the continued purchase of their maintenance and repair products and authorized services. Congress has provided consumers with this protection under the Magnuson-Moss Warranty Act as well as specific provisions of the Federal Trade Commission Improvement Act.

It's against the law for an original equipment manufacturer to inform consumers that their warranty would be void should they use other than genuine replacement parts or if service were to be performed by anyone other than an authorized "OEM" dealer unless, of course, such parts and service were to be performed "Free of Charge" under the terms of the warranty.

The laws were enacted to grant the consumers and dealers the basic right to select replacement parts from competent manufacturers without fear of jeopardizing their warranty. The law directly provides the consumer the right of choice, the right to an affordable alternative choice of manufactured product. Of course, the original equipment manufacturer is not responsible for product failures or damages caused by product failures of product manufactured by others. Such damages become the responsibility of the company providing such products under the terms of their own warranties. Barr Marine by EDM originated the three-year limited warranty that has recently become the standard for all others to follow. Our warranty can be found in our catalog directly following this notice.

Barr Marine by EDM has been a manufacturer of Marine Engine Parts for seventy-three years. The company has and continues to manufacture marine engine parts for many of the original equipment manufacturers. For years, we have represented the affordable alternative choice for your needs. We thank you for your continued support!

Barr Marine By EDM
P.O. Box 190
100 Douglas Way
Natural Bridge Station, VA. 24579
Ph. # 1-540-291-4180
Fax # 1-540-291-4185



BARR MARINE BY EDM 1 YEAR ENGINE WARRANTY

Long Blocks
Pleasure Boat Applications

12 Months Parts and Labor*
24 Months Parts

Commercial or Charter Boats

12 Months Parts & Labor

Barr Marine expressly warrants that its engine is of good quality and free from defects in materials or workmanship. Purchaser acknowledges that Barr Marine has made no affirmation of fact or promise relating to its engines outside this Limited Warranty and Barr Marine has provided the purchaser no description, sample or model of its engine upon which the purchaser has relied in deciding to purchase a Barr Marine engine. Barr Marine will, at its sole discretion, replace defective parts or a complete engine. All repairs will be made at the seller's or distributors cost, plus applicable labor pursuant to the Labor Policy set forth below. **PRIOR AUTHORIZATION IS REQUIRED FROM BARR MARINE BEFORE WARRANTY WORK IS BEGUN.** Call Barr Marine at (866) 255-9265 for a numbered authorization. It is the sole responsibility of the ultimate purchaser/ owner to pay for such work and submit the alleged defective parts, written repair order showing all charges, and a written receipt for payment of all charges to Barr Marine for review and determination by Barr Marine that the engine failure is or is not covered by this Limited Warranty. Repairs or replacements do not extend this Limited Warranty.

Transferable

This Limited Warranty is transferable and is not limited to the ultimate purchase/owner at the time of the sale.

Labor Policy

Barr Marine will pay labor claims only to repair facilities it has authorized. Barr Marine will not be liable for or pay any labor claims on Barr Marine engines installed by a third party who is not a certified marine mechanic (Marine Certificate or equivalent). All labor expense for field repairs, removal or reinstallation shall be limited to that expense and to those hours listed in the most recent Motors Flat Rate Manual, or equivalent manual pre- approved by Barr Marine, at the prevailing labor rate for the area but not to exceed \$40.00 per hour. In no event shall the total amount of labor cost exceed \$350.00 for all boats 20 foot or shorter, \$450.00 for cabin cruisers 21 foot or longer. A \$100.00 crane allowance will be allowed on cabin cruisers 21 feet or longer in addition to the limitation on labor costs.

OWNER OBLIGATIONS

After 10 hours upon initial startup, ultimate purchase/owner shall assure that a certified licensed and qualified mechanic authorized by Barr Marine inspects your engine, which inspection should include, but is not limited to, adjustment of tappets (if applicable), adjustment of valves, timing and carburetor adjustments, tightening of gasket bolts (Barr Marine recommends retorquing gasket bolts regardless of gasket type), and a change of oil and oil filter. Carefully monitor oil levels for the first 100 hours as oil consumption may be higher during this period. Use good quality motor oil of the appropriate grade and viscosity as recommended by the original engine manufacturer. Barr Marine recommends against the use of synthetic oils or non-detergent oil, the use of which by the ultimate purchaser/owner shall void this Limited Warranty. Proper oil pressure and lubrication are mandatory for good engine break-in. All boats should be equipped with gauges or lights to indicate engine temperature and oil pressure. **DO NOT OPERATE BOAT WITH ABNORMAL OIL PRESSURE OR WATER TEMPERATURE.** After initial startup, avoid excessive RPM and keep boat on plane. Vary RPM range for first 3 to 5 hours running time. High engine RPM may damage your new engine through friction and high temperatures. Avoid long period of idling. Engine overheating and failure due to lack of lubrication can be prevented by adequate monitoring of all gauges or lights and should never in the absence of neglect by the purchaser result in engine damage.

Continued



Limitations & Exclusions

ALL OTHER WARRANTIES EXPRESS OR IMPLIED, AND ALL IMPLIED WARRANTIES (INCLUDING MERCHANTABILITY AND FITNESS FOR A PARTICULAR PURPOSE) ARE HEREBY EXCLUDED AND NO WARRANTIES EXIST WHICH EXTEND BEYOND THE DESCRIPTION IN THE EXPRESS LIMITED WARRANTY ON THE FACE OF THIS DOCUMENT WITH REGARD TO ANY ENGINE OR PART PROVIDED BY BARR MARINE. NO ORAL STATEMENTS BY ANY PERSON, DISTRIBUTOR OR SALESMAN MAY MODIFY OR CHANGE THIS LIMITED WARRANTY. NO TERM OF ANY PURCHASE ORDER OR OTHER FORM THE PURCHASER OR DISTRIBUTOR/SELLER SHALL MODIFY OR CHANGE THIS LIMITED WARRANTY.

THIS LIMITED WARRANTY IS NOT AN UNCONDITIONAL WARRANTY AGAINST ALL HAZARDS OR FAILURES. BARR MARINE SHALL NOT BE RESPONSIBLE FOR:
DAMAGE OR REPAIRS REQUIRED AS A CONSEQUENCE OF FAULTY INSTALLATION/MISAPPLICATION, ABUSE, IMPROPER SERVICING, UNAUTHORIZED ALTERATION OR IMPROPER OPERATION.

PARTS NOT SUPPLIED BY BARR MARINE (INCLUDING BUT NOT LIMITED TO PAN, MANIFOLDS AND COVERS, WATER PUMPS, FUEL PUMPS, DISTRIBUTOR AND CARBURATOR OR FUEL INJECTION SYSTEMS), OR DAMAGES RESULTING FROM THE USE OF PARTS NOT SUPPLIED BY BARR MARINE.

DAMAGES RESULTING FROM DETONATION OR PRE-IGNITION, INCLUDING BUT NOT LIMITED TO MELTED OR BROKEN PISTONS, BROKEN OR SCORED RINGS, DAMAGED CYLINDER HEADS OR GASKETS, SCORING ON CYLINDER WALLS OR PISTON HEADS.

DAMAGES RESULTING FROM IMPROPER PRE-LUBRICATION PRIOR TO STARTUP.

THE ULTIMATE PURCHASERS/OWNERS EXCLUSIVE REMEDY AGAINST BARR MARINE SHALL BE FOR THE REPLACEMENT OF THE ENGINE OR PAY, AT DISTRIBUTORS COST, THE COST OF MATERIALS USED FOR REPAIRS AS SET FORTH ABOVE. NO OTHER REMEDY (INCLUDING, BUT NOT LIMITED TO, ANY SPECIAL, DIRECT OR INDIRECT, INCIDENTAL OR CONSEQUENTIAL DAMAGES, SUCH AS LOST PROFITS, LOST SALES, INJURY TO PERSON OR PROPERTY, TOWING, OIL LUBRICATIONS, FILTERS, ANTIFREEZE, GASKETS, SHIPPING AND FREIGHT, LOSS OF USE OF VEHICLE OR LOSS OF TIME OR ANY OTHER INCIDENTAL OR CONSEQUENTIAL LOSS) SHALL BE AVAILABLE TO THE ULTIMATE PURCHASER/OWNER.

NO WARRANTY FROM INDMAR PRODUCTS CO., INC.

INDMAR PRODUCTS CO., INC. GIVES NO WARRANTY, EXPRESS OR IMPLIED, AS TO DESCRIPTION, QUALITY, MERCHANTABILITY, FITNESS FOR ANY PARTICULAR PURPOSE, PRODUCTIVENESS, OR ANY OTHER MATTER OF ANY GOODS WHICH ARE SUPPLIED BY BARR MARINE. INDMAR PRODUCTS CO., INC. SHALL BE IN NO WAY RESPONSIBLE FOR THEIR PROPER USE, IN SERVICE AND THE PURCHASER HEREBY WAIVES ALL RIGHTS OF REFUSAL AND RETURN OF GOODS. THE PURCHASER ACKNOWLEDGES THAT INDMAR PRODUCTS CO., INC HAS GIVEN NO WARRANTY AND THAT THE ONLY WARRANTY THAT PURCHASER SHALL HAVE SHALL BE SUCH WARRANTY, IF ANY, FROM BARR MARINE AS SET FORTH ABOVE AND THE PURCHASER SHALL LOOK SOLELY TO BARR MARINE.

Governing Law & Venue

The terms and provisions of the Limited Warranty, and each and every document related to this Limited Warranty, shall be governed by and construed according to the laws of the State of Virginia. Any action at law, suit in equity or judicial proceeding for the enforcement of the Limited Warranty or any provision thereof shall be instituted only in the courts of Virginia.



BARR MARINE BY EDM 2 YEAR ENGINE WARRANTY

BARR MARINE BY EDM LIMITED PRODUCT WARRANTY

1. **Warranty.** Pursuant to the terms and conditions and exclusions herein, Barr Marine by EDM, 100 Douglas Way, P.O. Box 190, Natural Bridge Station, Virginia 24579 ("Barr Marine"), warrants that its marine propulsion engine, factory installed accessories and the parts related thereto (collectively, "Product") are free from material defects in material and workmanship under normal use and service during the applicable warranty period as set forth herein.

2. **Coverage.** Barr Marine shall replace or repair any defect in material or workmanship relating to the Product under the terms and conditions of this Limited Product Warranty. Components or parts of the Product that Barr Marine determines in its sole discretion to be "worn-out" from use are specifically excluded from this Limited Product Warranty. If a Product or defective part thereof is, upon examination by Barr Marine, determined in sole opinion by Barr Marine to be defective, Barr Marine shall repair, or at its sole option, provide either a new or rebuilt replacement of equivalent quality. Barr Marine shall have the sole discretion to determine whether the replacement, if provided, shall be a new or rebuilt replacement. Barr Marine's sole obligation under this Limited Product Warranty is limited only to the foregoing obligations and exclusions as stated herein. The Limited Product Warranty shall only be available to Customers who complete and properly fill out and deliver to Barr Marine an authorized Barr Marine Warranty Registration card within ten (10) days of purchase of the Product as set forth herein.

3. **Customer.** This Limited Product Warranty is extended only to the original retail purchaser of a boat in which a Product has been installed pursuant to Barr Marine's approval or authority ("Customer"). If the boat is sold or traded prior to the end of the applicable warranty period set forth herein, the remainder of the applicable warranty period is transferable to the new owner (also referred herein as "Customer") provided that all of the requirements for a valid transfer as set forth in this Limited Product Warranty are satisfied. No transfer of any rights by any Customer shall be deemed valid or effective unless and until approved in writing by Barr Marine. Warranties of any nature to any person other than those described herein are specifically excluded.

4. **Excluded Items.** In addition to, and without in any way limiting, any exclusion set forth elsewhere in this Limited Product Warranty, this Limited Product Warranty shall not apply to the following items:

- (a) Shop supplies used in performing work pursuant to this Limited Product Warranty, including, but not limited to, rags, sealants and lubricants.
- (b) Incidental, punitive and/or consequential damages, including, but not limited to, storage charges, attorney fees, telephone or rental charges of any type, inconvenience or loss of time or income.
- (c) Minor adjustments and tune-ups, including, but not limited to, checking, cleaning or adjusting spark plugs, carburetor setting, filters, belts, controls and checking lubrication.
- (d) Water pump impellers, water hoses, cooling system anodes, or any component determined solely by Barr Marine to be damaged from the failure of any of such items.
- (e) Product failure as determined solely by Barr Marine to be caused by neglect, lack of maintenance, accident, abnormal operation, improper installation, improper preparation, improper winterization, improper dealer set-up, improper service or normal wear and tear.
- (f) Haul-out, launch, and towing charges.
- (g) Cost and expense incurred that relate to the removal and/or replacement of boat partitions or material due to boat design for necessary access to the Product.
- (h) Transportation charges and travel time incurred by Barr Marine to fulfill any of its obligations pursuant to this Limited Product Warranty.

Continued



- (i) Service or work to the Product as requested by the Customer that is as determined solely by Barr Marine to be beyond the scope of this Limited Product Warranty.
- (j) Use of parts other than Barr Marine parts (or parts authorized by Barr Marine) and the use of labor other than Barr Marine labor (or labor authorized by Barr Marine) when making repairs or providing a replacement under this Limited Product Warranty.
- (k) Oil, lubricants or fluids used for the normal maintenance of the Product.
- (l) Defects to the Product as determined solely by Barr Marine to be caused by or due to participation in or preparing for racing or other competitive activity.
- (m) Defects to the starter motor, armatures or field coil assembly of the Product as determined solely by Barr Marine to be caused by excessive cranking, condensation or submersion.
- (n) Defects to the Product as determined solely by Barr Marine to be caused by water entering the Product via the intake or exhaust system or submersion.
- (o) Defects to the Product as determined solely by Barr Marine to be caused by the use of fuels and lubricants that are not suitable for use with or on the Product or its fuel system components that was damaged or rendered inoperable from stale gasoline.
- (p) Defects to the Product as determined solely by Barr Marine to be caused by the lack of cooling water resulting from the motor being started out of water or foreign materials blocking intake passages.
- (q) Defects to the Product as determined solely by Barr Marine to be caused by servicing errors made by the Customer or by any servicing dealer/mechanic not approved or authorized by Barr Marine.
- (r) Product warranty claims that Barr Marine in its sole opinion determines are not due or traceable to material defects in material or workmanship of the Product; or
- (s) Delivery fees, including but not limited to, air freight, next-day or second-day air, or any special delivery fee or expense unless authorized by Barr Marine prior to ordering of parts and prior to any work or service provided by Barr Marine pursuant to this warranty, including but not limited to its ordering of parts.

5. **Inspection and Testing of Product.** Certain parts of the Product may be tested upon receipt by Barr Marine. Such parts of the Product found to be free of defects in Barr Marine's sole opinion will be returned to the Customer at Customer's expense and no credit will be issued to the Customer. Barr Marine reserves the right to retrieve run time/run condition data from a Product's Electric Control Module prior to granting any warranty coverage on the Product under this Limited Product Warranty.

6. **Warranty Period.** Warranty coverage shall be provided only for the periods of time hereinafter set forth for the Product:

- (i) A period of twenty-four (24) months commencing from the date of purchase or the date of commencement of the Product use, whichever sooner occurs, in the case of non-commercial use;
- (ii) A period of three (3) months commencing from the date of purchase or the date of commencement of the Product use, whichever sooner occurs, in the case of commercial use.

In the event that more than one warranty time period may be applicable to a particular Product pursuant to this Section 6, the shorter period of time shall apply and shall be the only warranty time period allowed for that Product.

Continued



The repair or replacement of parts or the performance of service under this Limited Product Warranty does not extend the applicable period of this warranty beyond its original expiration date as set forth herein.

7. **Procedure.** Within 10 days from the date of purchase by the original retail purchaser of the Product, the Customer shall complete and deliver the Barr Marine Warranty Registration Card to Barr Marine; or Indmar Products Co. If the Barr Marine Warranty Registration Card is not completed and delivered as set forth herein the Product will be excluded from all warranties set forth herein. In addition to other requirements set forth herein, no warranty claim will be honored without Barr Marine's prior timely receipt of a completed Barr Marine Warranty Registration Card. In the case of a warranty transfer to a subsequent owner, the new owner's information along with a check for \$50.00 made payable to "Barr Marine Warranty Transfer" must be sent to Barr Marine within 10 days of the transfer. No transfer shall be effective or valid unless and until approved by Barr Marine in its sole discretion. For warranty claims to be asserted hereunder, the Product or defective part thereof, together with a written notice of itemized defects must be returned to the retailer from whom the Product was purchased or to any other convenient Barr Marine authorized dealer. To obtain the location of an authorized Barr Marine dealer or service center in your area, write to Barr Marine requesting such information or visit www.barrmarine.net. In the event that the local authorized Barr Marine dealer is unable to remedy a warranted defect in the Product, the Product or defective part thereof, together with a written notice of itemized defects, must be delivered to Barr Marine at 100 Douglas Way, P.O. Box 190, Natural Bridge Station, Virginia 24579 with any and all freight and insurance charges prepaid. All insurance and freight charges and return charges incurred by Barr Marine for delivery of the Product (or its new or rebuilt replacement) to the retail purchaser shall be paid by such purchaser. The Customer shall be solely responsible for any and all labor expenses related to the repair or replacement of a Product pursuant to this Limited Product Warranty that exceed the specified services rates of Barr Marine in effect at the date of purchase. A schedule of service rates of Barr Marine may be obtained from any authorized Barr Marine dealer.

8. **Trade Accessories.** Barr Marine makes no warranty of any character with respect to any and all trade accessories not manufactured by Barr Marine or not installed by Barr Marine or pursuant to Barr Marine's written authority.

9. **Voiding the Warranty.** In addition to any requirement set forth in this Limited Product Warranty not being met or satisfied, this Limited Product Warranty shall become void and shall not apply under the following conditions or circumstances:

- (a) When the Product or any part thereof is subject to accident, alternation, modifications, abuse, misuse, neglect or improper maintenance in Barr Marine's sole determination;
- (b) When the Product is serviced by any individual or entity not authorized or approved in writing by Barr Marine; or
- (c) When damage to the Product results from cases not arising from defects in material and/or workmanship in Barr Marine's sole determination.

10. **Notices.** Any notice to Barr Marine set forth pursuant to this Limited Product Warranty shall be delivered to the following address:

Barr Marine by EDM
100 Douglas Way
P.O. Box 190
Natural Bridge Station, VA 24579

11. **Warranty Claims Made Outside the United States.** In the event that Barr Marine fulfills a warranty claim outside the United States pursuant to this Limited Product Warranty, the Customer shall be solely responsible for any and all additional charges which Barr Marine may incur in order to fulfill its warranty obligations outside the United States. Barr Marine will not provide warranty coverage on any Product sold outside the United States unless the warranty work or service is performed by a marine technician certified by a major inboard or sterndrive marine engine manufacturer approved and authorized in writing by Barr Marine.

Continued



12. Limitation. THE WARRANTY STATED ABOVE IS A LIMITED WARRANTY AND IT IS THE ONLY WARRANTY MADE BY BARR MARINE. BARR MARINE DOES NOT MAKE ANY OTHER WARRANTIES EXPRESS OR IMPLIED. THERE ARE EXPRESSLY EXCLUDED ALL WARRANTIES OF MERCHANTABILITY AND FITNESS FOR A PARTICULAR PURPOSE. BARR MARINE SHALL HAVE NO LIABILITY WITH RESPECT TO ITS OBLIGATIONS UNDER THIS LIMITED WARRANTY OR OTHERWISE FOR CONSEQUENTIAL, EXEMPLARY, INCIDENTAL OR PUNITIVE DAMAGES EVEN IF IT HAS BEEN ADVISED OF THE POSSIBILITY OF SUCH DAMAGES. THE STATED EXPRESS LIMITED WARRANTY IS IN LIEU OF ALL LIABILITIES OR OBLIGATIONS OF BARR MARINE FOR DAMAGES ARISING OUT OF OR IN CONNECTION WITH THE DEVELOPMENT, DELIVERY, USE OR PERFORMANCE OF THE PRODUCT. IN ANY EVENT, THE LIABILITY OF BARR MARINE FOR ANY REASON AND UPON ANY CAUSE OF ACTION WHATSOEVER SHALL BE LIMITED TO THE AMOUNT THEN PREVIOUSLY PAID FOR THE PRODUCT BY THE CUSTOMER.

BARR MARINE DOES NOT AUTHORIZE ANY PERSON, EMPLOYEE, AGENT, REPRESENTATIVE OR ENTITY TO ALTER ANY OF THE TERMS AND CONDITIONS OF THIS LIMITED PRODUCT WARRANTY OR CREATE ANY OTHER OBLIGATION RELATING TO THE PRODUCT. THIS WARRANTY GIVES YOU SPECIFIC LEGAL RIGHTS, AND YOU MAY ALSO HAVE OTHER RIGHTS WHICH MAY VARY FROM STATE TO STATE.

NOTICE TO CALIFORNIA CUSTOMERS: CALIFORNIA CUSTOMERS MUST DIRECTLY NOTIFY BARR MARINE IN WRITING IF THE PRODUCT DOES NOT CONFORM TO APPLICABLE WARRANTIES AND (A) THE NON-CONFORMITY IS LIKELY TO CAUSE DEATH OR SERIOUS BODILY INJURY AND HAS BEEN SUBJECT TO REPAIR TWO (2) OR MORE TIMES, AND/OR (B) THE NON-CONFORMITY HAS BEEN SUBJECT TO REPAIR FOUR (4) OR MORE TIMES. CALIFORNIA CUSTOMERS ARE HEREBY NOTIFIED TO THE FOLLOWING PROVISIONS OF CALIFORNIA LAW: CAL. CIVIL CODE § 1793.22 AND CAL. CIVIL CODE § 1793.2(d). COMPLETE COPIES OF THESE CODE SECTIONS ARE AVAILABLE UPON REQUEST.

Any/all litigation under this Warranty or arising out of the Product must be filed within the state of Virginia, County of Rock-bridge.



NEW!!

5.0L GM “Long Block/Green” (vortec) Marine Engine Quest Part # 051070G

The Quest 5.0L new “Long Block” engine includes the following (when ordered under the above part number).

Block (with all internal engine components)
Water Circulating Pump
14” Flywheel

Harmonic Balancer
Timing Chain Cover
Oil Pan

Valve Covers
Spark Plugs

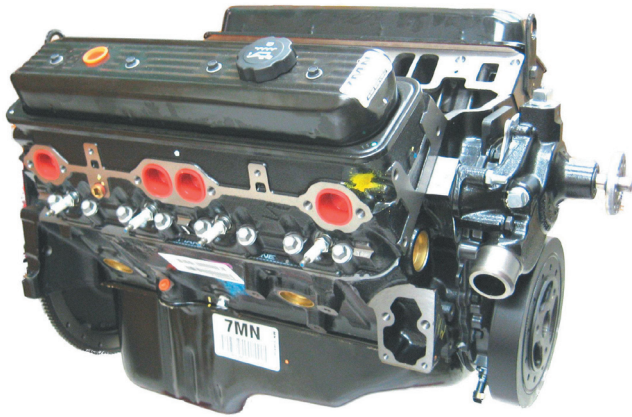

Specifications

Displacement:	305 C.I.D. (4999 CC) / 5.0L
Cylinders:	90 Degree V8 Cylinder
Comp. Ratio:	9.4:1
Valve Config.:	Overhead Valves (2 valves per cylinder)
Valve Lifters:	Hydraulic Roller
Bore x Stroke:	3.80” x 3.48” (95 x 88.39 mm)
Main Bearings Caps:	Cast Iron GM232-M
Ignition:	Customer Supplied
Intake Manifold:	Customer Supplied (Vortec Style)
Block MFG.:	GM Powertrain
Flywheel Dia.:	14” (Ring Gear Towards Engine)
Firing Order:	1 - 8 - 4 - 3 - 6 - 5 - 7 - 2
Oil Pan Capacity:	5.5 Quarts (With Filter)
Oil Type:	SAE 15W40 Pennzoil Marine
Horsepower:	253 H.P. @ 4800 RPM (Carburetor)
Torque:	302 lb-ft @ 3800 RPM
Warranty:	1 Year Limited (90 Days Commercial)

Note: Actual power levels may vary depending on Quest’s calibration and application.

Available Options:

-A full range of new replacement parts needed to complete the build up!

-12 3/4” Flywheel Order Part # 24-14088650

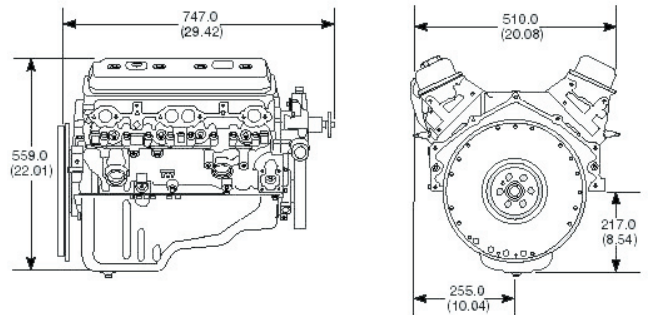

Toll Free: 1-866-255-9265

www.barrmarine.net

Suppliment



NEW!!

5.7L GM “Enhanced Base” MPI Marine Engine

Quest Part # 041009

The Quest 5.7L new “Enhanced Base” MPI engine includes the following (when ordered under the above part number).

Block (with all internal engine components)
Water Circulating Pump
14” Flywheel
Electronic Ignition System (MPI)
Flame Arrestor
Circ. Pump Pulley
Starter

Harmonic Balancer
Timing Chain Cover
Oil Pan
Fuel Injection System
Thermostat Housing
Crank Shaft Pulley
Dipstick/Tube

Valve Covers
Spark Plugs
Plug Wires
Intake
T-HSG Hose
Alternator
Wire Harness

MEFI 5 ECM (w/ Pedal Position Sensor for manual cable)

Throttle Bracket



Specifications

Displacement:	350 C.I.D. (5736 CC) / 5.7L
Cylinders:	90 Degree V8 Cylinder
Comp. Ratio:	9.4:1
Valve Config.:	Overhead Valves (2 valves per cylinder)
Valve Lifters:	Hydraulic Roller
Bore x Stroke:	4.00” x 3.48” (101.60 x 88.39 mm)
Main Bearings Caps:	Cast Iron GM232-M
Ignition:	High Voltage Switch (MEFI 5)
Intake Manifold:	MPI
Block MFG.:	GM Powertrain
Flywheel Dia.:	14” (Ring Gear Towards Engine)
Firing Order:	1 - 8 - 4 - 3 - 6 - 5 - 7 - 2
Oil Pan Capacity:	5.5 Quarts (With Filter)
Oil Type:	SAE 15W40 Pennzoil Marine
Horsepower:	325 H.P. @ 5200 RPM (MPI)
Torque:	370 lb-ft @ 3200 RPM
Warranty:	1 Year Limited (90 Days Commercial)

Note: Actual power levels may vary depending on Quest’s calibration and application.

Available Options:

-A full range of new replacement parts needed to complete the build up!

-12 3/4” Flywheel Order Part # 24-14088650

The Quest “Enhanced Base” fuel and spark is brand new and the perfect engine for the boater who requires a new power plant in their boat. This engine is and excellent replacement for customer who has existing components they want to re-install to get their boat back in the water!

Please Call about our full line of Transmissions!



Toll Free: 1-866-255-9265

www.barrmarine.net

Supplement



NEW!!

3.0L GM Base Marine Engine

Quest Part # 051079N

The Quest 3.0L new base engine includes the following (when ordered under the above part number).

Block (with all internal components)
 Water Circulating Pump
 Spark Plugs
 14" Flywheel
 Oil Pan

Harmonic Balancer
 Electronic Distributor
 High Output Coil
 Timing Shunt
 Power Tach Lead

Valve Cover
 Timing Chain Cover
 Interrupter Harness
 Cable / Coil to Distributor



Specifications

Displacement:	181 C.I.D. (2966.59 CC) / 3.0L
Cylinders:	In-Line 4 Cylinder
Comp. Ratio:	9.25:1 (High Flow Vortec Head)
Valve Config.:	Pushrod Actuated / Overhead Valves
Valve Lifters:	Hydraulic Flat Tappet
Bore x Stroke:	4.00" x 3.60" (101.60 x 91.44 mm)
Main Bearings:	2 Bolt Cast Iron
Ignition:	Delco EST (Electronic)
Intake/Exhaust Manifold:	Customer Supplied
Block MFG.:	GM Powertrain
Flywheel Dia.:	14" (Ring Gear Towards Engine)
Firing Order:	1 - 3 - 4 - 2
Oil Pan Capacity:	4 Quarts (W/O Filter)
Oil Type:	SAE 15W40 Pennzoil Marine
Paint Protectant:	High Gloss Black / Superior Corrosion Resistant
Horsepower:	140 H.P. @ 4800 RPM (Carburetor)
Torque:	177 lb-ft @ 3600 RPM
Warranty:	1 Year Limited (90 Days Commercial)

Note: Actual power levels may vary depending on Quest's calibration and application.

Quest is currently working on Fuel and Spark and Bobtail versions of this engine!

Please call for availability!

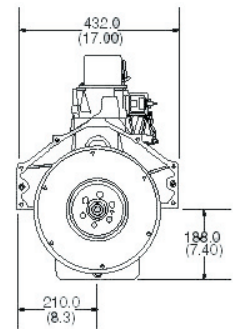
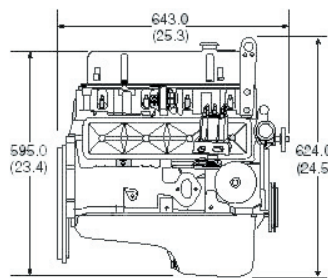

Toll Free: 1-866-255-9265
www.barrmarine.net



NEW!!

4.3L GM Base Marine Engine

Quest Part # 051028N

The Quest 4.3L new base engine includes the following (when ordered under the above part number).

Block (with all internal engine components)
 Water Circulating Pump
 14" Flywheel

Harmonic Balancer
 Timing Chain Cover
 Cast Iron Intake (2 barrel)

Valve Covers
 Spark Plugs
 Oil Pan

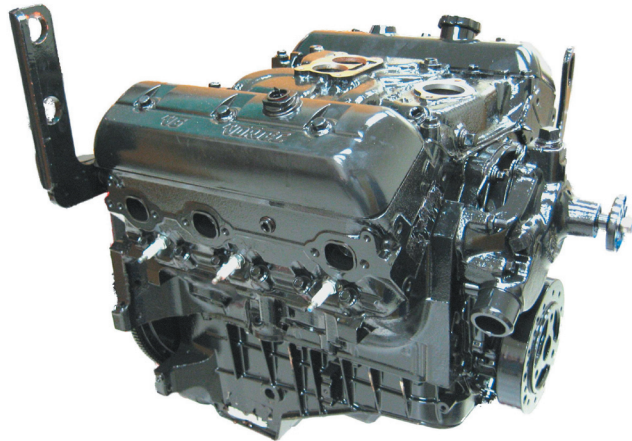

Specifications

Displacement:	262 C.I.D. (4294 CC) / 4.3L
Cylinders:	90 Degree V6 Cylinder
Comp. Ratio:	9.4:1
Valve Config.:	Overhead Valves (2 valves per cylinder)
Valve Lifters:	Hydraulic Roller
Bore x Stroke:	4.00" x 3.48" (101.60 x 88.39 mm)
Main Bearings Caps	Cast Iron GM232-M
Ignition:	Customer Supplied
Intake Manifold:	Cast Iron (2 Barrel Carburetor)
Block MFG.:	GM Powertrain
Flywheel Dia.:	14" (Ring Gear Towards Engine)
Firing Order:	1 - 6 - 5 - 4 - 3 - 2
Oil Pan Capacity:	4.5 Quarts (W/O Filter)
Oil Type:	SAE 15W40 Pennzoil Marine
Paint Protectant:	High Gloss Black / Superior Corrosion Resistant
Horsepower:	223 H.P. @ 4800 RPM (Carburetor)
Torque:	267 lb-ft @ 2800 RPM
Warranty:	1 Year Limited (90 Days Commercial)

Note: Actual power levels may vary depending on Quest's calibration and application.

Available Options:

-A full range of new replacement parts needed to complete the build up!

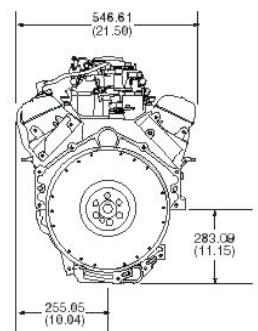
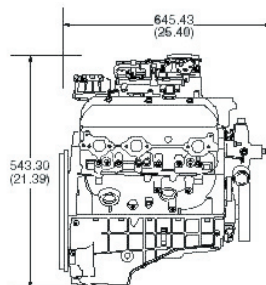

Toll Free: 1-866-255-9265
www.barrmarine.net



NEW!!

4.3L GM “Enhanced Base” Marine Engine

Quest Part # 051000

The Quest 4.3L new “Enhanced Base” engine includes the following (when ordered under the above part number).

Block (with all internal engine components)
 Water Circulating Pump
 14” Flywheel
 Electronic Distributor (HEI-Delco)
 Carburetor (Holley/600 cfm)

Harmonic Balancer
 Timing Chain Cover
 Oil Pan
 Fuel Pump (electronic)
 Thermostat Housing

Valve Covers
 Spark Plugs
 Plug Wires
 Coil
 T-HSG Hose



Specifications

Displacement:	262 C.I.D. (4294 CC) / 4.3L
Cylinders:	90 Degree V6 Cylinder
Comp. Ratio:	9.4:1
Valve Config.:	Overhead Valves (2 valves per cylinder)
Valve Lifters:	Hydraulic Roller
Bore x Stroke:	4.00” x 3.48” (101.60 x 88.39 mm)
Main Bearings Caps	Cast Iron GM232-M
Ignition:	Customer Supplied
Intake Manifold:	Cast Iron (4 Barrel Carburetor)
Block MFG.:	GM Powertrain
Flywheel Dia.:	14” (Ring Gear Towards Engine)
Firing Order:	1 - 6 - 5 - 4 - 3 - 2
Oil Pan Capacity:	4.5 Quarts (W/O Filter)
Oil Type:	SAE 15W40 Pennzoil Marine
Paint Protectant:	High Gloss Black / Superior Corrosion Resistant
Horsepower:	223 H.P. @ 4800 RPM (Carburetor)
Torque:	267 lb-ft @ 2800 RPM
Warranty:	1 Year Limited (90 Days Commercial)

Note: Actual power levels may vary depending on Quest’s calibration and application.

Available Options:

-A full range of new replacement parts needed to complete the build up!

The Quest “Enhanced Base” fuel and spark is brand new and the perfect engine for the boater who requires a new power plant in their boat. This engine is an excellent replacement for customer who has existing components they want to re-install to get their boat back in the water!



Toll Free: 1-866-255-9265
www.barrmarine.net



NEW!!
4.3L GM “Bobtail” Marine Engine
Quest Part # 51003

The Quest 4.3L “Bobtail” engine includes the following (when ordered under the above part number).

The Quest Enhanced Base (part #051000) plus:

- | | | |
|--------------------------------------|-----------------------------------|----------------------------------|
| Exhaust System (Volvo or MerCruiser) | Coupler (Volvo or MerCruiser) | Alternator |
| Throttle Linkage | Starter (bottom mount) | Engine Wiring Harness |
| Fuel/Water Sep. (I/O only) | Weather Cover | E Z Oil Drain |
| Dipstick and Tube | Crank Pulley | Circ. Pump Pulley |
| Flywheel Hsg. (where applicable) | Torsion Damper (where applicable) | Dust Cover (where applicable) |
| | | Flame Arrestor |
| | | High Gloss Paint (non-corrosive) |
| | | P/U Pump (when applicable) |

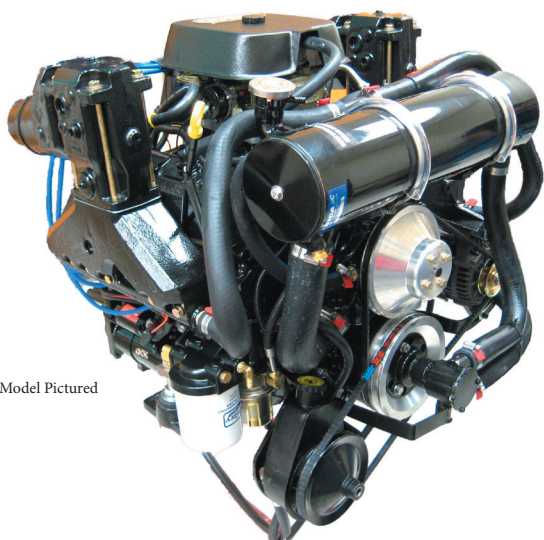

Volvo I/O Model Pictured

The “Bobtail” engines by Quest are built only with premium components to insure many years of boating! These super high quality engines have everything factory installed to make sure your customer’s complete engine replacement is a smooth transaction!

Please give the folks at Barr Marine By EDM or one of our very fine engine distributors a call and we will be glad to help you get started breathing life back into your boat!

Bobtail Without Exhaust Order Part #051002

Please Call about our full line of Transmissions!

Note: Closed cooling system, power steering system, and fuel water separator are shown but must be purchased in addition to the bobtail engine. Fuel / water separator is only included on I/O Bobtails only (at no extra charge).

Available Options:

- Power Steering System (w/ oil cooler)
- Closed Cooling (Half or Full System)

2 YEAR WARRANTY!



Toll Free: 1-866-255-9265
www.barrmarine.net



Replacement Block Components and Related Parts For The 4.3L Carbureted Engine

All replacement parts are from only the best manufacturers and are used on our production engines as well!



885016



531009



535033



8 0006



535011



MC 8 66418

4.3L Block Components

Part Number	Part Description
MC 8 66418	Front Engine Mount (Merc. replacement-in pairs)
885016	Drive Plate (torsion damper)
531009	Flywheel Housing (bottom mount starter)
535033	Splash Plate (bottom mount starter)
531005	Front Engine Mount, RH (to block)
531004	Front Engine Mount, LH (to block)
515003KIT	E-Z Oil Drain Kit (metric thread)
25 1000	Power Steering Kit (only installed at Barr Marine)
495121	Remote Oil Filter Kit

Part Number	Part Description
8 0006	Stringer Mount (for #MC 8 66418)
535011	Transmission Mount (for direct drive ZF Trans.)
535015R	Trans. Mount (RH-for reduction and V-Drive ZF)
535015L	Trans. Mount (LH-for reduction and V-Drive ZF)
535021	Trunion (for #531004 & 5)
535032	Stringer Mount (flat)
551660	Dipstick (V6 engine)
551661	Dipstick Tube (V6 engine)

Note: The Quest Power Steering System is not for sale unless sold as a direct replacement or sold already installed on a Quest bobtail engine! It is recommended that the new Power Steering System is installed on all bobtail engines.

BARR
MARINE BY EDM

Toll Free: 1-866-255-9265
www.barrmarine.net



Replacement Cooling System and Related Parts For The 4.3L Carbureted Engine

All replacement parts are from only the best manufacturers and are used on our production engines as well!



981108



981204



685001



041242



041494

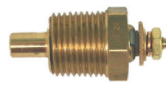

645001



CHV 29 80



MC 2 17437

4.3L Cooling System

Part Number	Part Description
981001	Pick Up Pump Bracket (old style)
981108	Pick Up Pump Bracket "A" (new style)
981204	Pick Up Pump Bracket "B" (new style)
685001	Pick Up Pump, Complete (pump only)
685000	Pick Up Pump Rebuild Kit
845010	Hose, Circ. Pump to Thermostat Housing
551240	Single Groove Circ. Pump Pulley
041242	Dual Groove Circ. Pump Pulley
551241	Single Groove Crank Pulley
041494	Dual Groove Crank Pulley
531067	Thermostat Housing (low profile)

Part Number	Part Description
CHV 29 80	Thermostat Housing (Barr style)
531093	1/2" Spacer, T-Stat Housing
986034	Thermostat (drilled for FWC)
MC47 27 53045	Gasket, Intake to Thermostat Housing
551045	Circulation Pump (GM Style)
MC 2 17437	Circulation Pump (Barr style)
MC47 27 34897	Gasket, Circ Pump to Engine
645001	Temperature Sender
BA 37 0350	Closed Cooling System (full)
BA 37 0000	Closed Cooling System (half)
531015	Thermostat Housing (Indmar Style)

Note: See the Barr Marine By EDM catalog for exhaust system options. All "bobtail" engines purchased with exhaust will automatically includes "center rise" exhaust systems ONLY!

BARR
MARINE BY EDM

Toll Free: 1-866-255-9265
www.barrmarine.net



Replacement Electrical System and Related Parts For The 4.3L Carbureted Engine

All replacement parts are from only the best manufacturers and are used on our production engines as well!

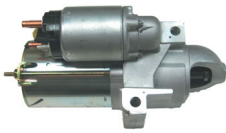

571006



575010



MC 27 93175



BA 27 0430



801059



556096



556194



80 473037

4.3L Electrical System

Part Number	Part Description
571006	Bottom Mount Starter
551306	Starter Bolt (single, bottom mount)
805061	Starter Relay (carbureted)
755001	Starter Solenoid (bottom mount)
575003	Starter Solenoid (top mount)
573001	Top Mount Starter (LH)
575001	Top Mount Starter (RH)
575010	Alternator (70 AMP)
MC 27 93175	Alternator Bracket (upper)
BA 27 0430	Alternator Bracket (lower)
27 0430	Bushing For 93175
50 170 235	Mounting Bolt For 93175
801059	Wire Harness

Part Number	Part Description
556096	Ignition Module
556051	Relay, Ignition and Fuel Pump
556084	Rotor (distributor)
556194	Pick Up Coil (distributor)
551006	Clamp, Distributor
551037	Clamp Bolt, Distributor
550003	Distributor Kit
80 473037	Wire Harness Adaptor (cannon style to square)
801012	Timing Shunt
986045	Lifting Eye (single)
50 270 012	Lock Washer For 93175
725036	Alternator Belt (vee)
805012	Spacer For Wire Harness



Toll Free: 1-866-255-9265
www.barrmarine.net



Replacement Fuel System and Related Parts For The 4.3L Carbureted Engine

All replacement parts are from only the best manufacturers and are used on our production engines as well!



BA 45 80492



981089



12550460



496002

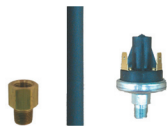

496007



525007



BA 45 188115

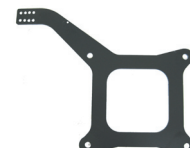

MC 45 0001

4.3L Fuel System

Part Number	Part Description
525007	Flame Arrestor w/ Vent Tube for ½" I.D. Hose
496007	Fuel Pump Safety Switch
BA 45 188115	Fuel Line (pump to carburetor)
605006	Fitting, 90 degree elbow (line in pump)
601008	Fitting, Inverted Flare (pump to fuel line)
12550460	Intake Manifold (4 barrel/cast iron)
MC 45 0005	Carburetor Gasket
981089	Throttle Bracket (Quest style)
BA 45 KIT	Fuel/Water Separator Kit

Part Number	Part Description
MC 45 0001	Throttle Bracket (Holley style)
496002	Carburetor Wedge Kit
986024	Rosette Knob (for flame arrestor)
605036	Hose, Vent Tube to Flame Arrestor
695002	Throttle Cable Clip
500001	Electronic Fuel Pump Kit
BA 45 80492	Carburetor (600 CFM/4 barrel)
BA 45 1932	Carburetor Adaptor (spread bore to square bore)
425036	Intake Manifold (2 barrel/take off)



Toll Free: 1-866-255-9265

www.barrmarine.net



NEW!!

5.7L GM “Long Block/Green” (vortec) Marine Engine

Quest Part # 051038G

The Quest 5.7L new “Long Block” engine includes the following (when ordered under the above part number).

Block (with all internal engine components)
 Water Circulating Pump
 14” Flywheel

Harmonic Balancer
 Timing Chain Cover
 Oil Pan

Valve Covers
 Spark Plugs

Specifications

Displacement:	350 C.I.D. (5736 CC) / 5.7L
Cylinders:	90 Degree V8 Cylinder
Comp. Ratio:	9.4:1
Valve Config.:	Overhead Valves (2 valves per cylinder)
Valve Lifters:	Hydraulic Roller
Bore x Stroke:	4.00” x 3.48” (101.60 x 88.39 mm)
Main Bearings Caps:	Cast Iron GM232-M
Ignition:	Customer Supplied
Intake Manifold:	Customer Supplied (Vortec Style)
Block MFG.:	GM Powertrain
Flywheel Dia.:	14” (Ring Gear Towards Engine)
Firing Order:	1 - 8 - 4 - 3 - 6 - 5 - 7 - 2
Oil Pan Capacity:	5.5 Quarts (With Filter)
Oil Type:	SAE 15W40 Pennzoil Marine
Horsepower:	292 H.P. @ 4800 RPM (Carburetor)
Torque:	370 lb-ft @ 3200 RPM
Warranty:	1 Year Limited (90 Days Commercial)

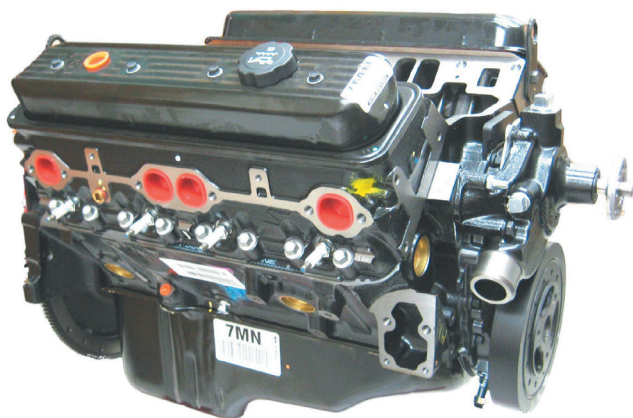

Note: Actual power levels may vary depending on Quest’s calibration and application.

Available Options:

- Reverse (Right Hand) Rotation Order Part # 042001
- A full range of new replacement parts needed to complete the build up!
- 12 3/4” Flywheel Order Part # 24-14088650

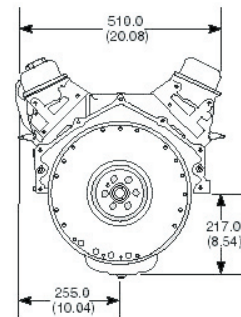
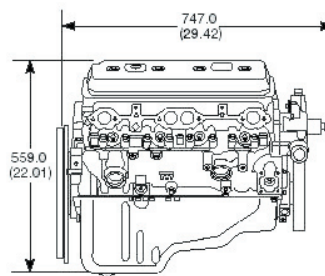

Toll Free: 1-866-255-9265
www.barrmarine.net



REMANUFACTURED

5.7L GM “Service Base” (vortec) Marine Engine

Quest Part # 021039-1030

The Quest 5.7L “Service Base” engine includes the following (when ordered under the above part number).

Block (with all internal engine components)
Water Circulating Pump
Oil Pan

Harmonic Balancer
Timing Chain Cover

Valve Covers
Spark Plugs

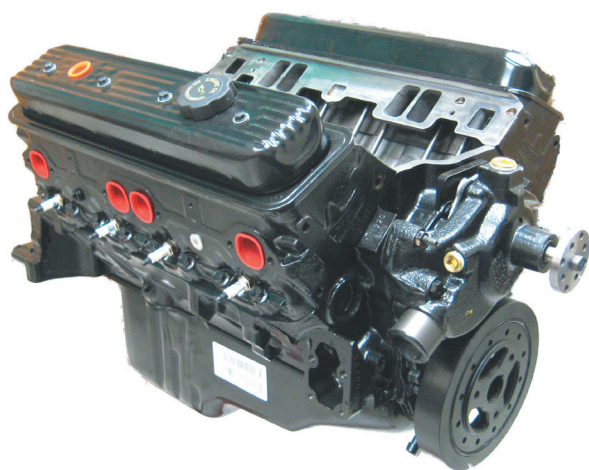

The “Service Base” engines by Quest are built only with premium components to insure many years of boating! These engines are fitted with General Motors “Vortec” heads and can be purchased in either Left Hand (standard) or Right Hand (opposite) rotation. The Quest “Service Base” engines are offered in a long block configuration and are perfect for the customer who wants to re-use their existing engine parts to complete the repower!

All of the components in our engines are totally re-machined, decked and pressure tested to NASCAR specifications at our own facility! This will provide you with the peace of mind that you have made the right choice in purchasing the BEST remanufactured marine engine on the market today.

Please give the folks at Barr Marine By EDM or one of our very fine engine distributors a call and we will be glad to help you get started breathing life back into your boat!

Available Options:

- Reverse (Right Hand) Rotation Order Part # 031039-1030
- A full range of new replacement parts needed to complete the build up!
- 12 3/4” Flywheel Order Part # 24-14088650

2 YEAR WARRANTY!

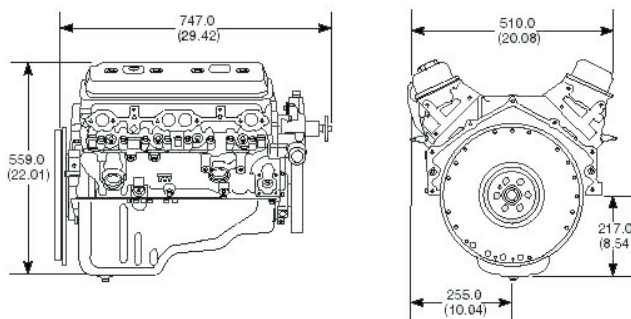

Flywheel not included in engine package.



Toll Free: 1-866-255-9265
www.barrmarine.net



NEW!!

5.7L GM “Enhanced Base” Marine Engine

Quest Part # 041000

The Quest 5.7L new “Enhanced Base” engine includes the following (when ordered under the above part number).

Block (with all internal engine components)
 Water Circulating Pump
 14” Flywheel
 Electronic Distributor (HEI-Delco)
 Carburetor (Holley/4150-600 CFM)

Harmonic Balancer
 Timing Chain Cover
 Oil Pan
 Fuel Pump (electronic)
 Thermostat Housing

Valve Covers
 Spark Plugs
 Plug Wires
 Coil
 T-HSG Hose

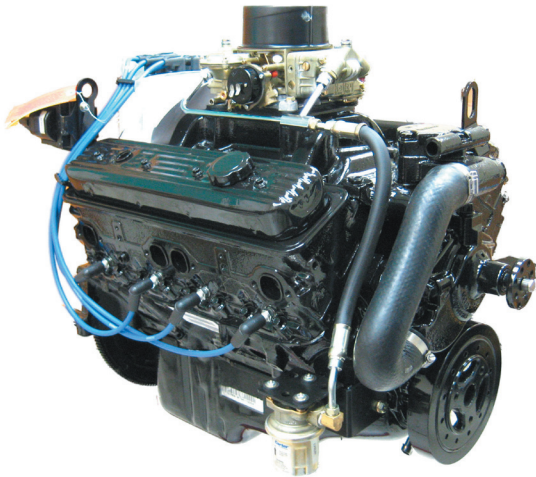

Specifications

Displacement: 350 C.I.D. (5736 CC) / 5.7L
 Cylinders: 90 Degree V8 Cylinder
 Comp. Ratio: 9.4:1
 Valve Config.: Overhead Valves (2 valves per cylinder)
 Valve Lifters: Hydraulic Roller
 Bore x Stroke: 4.00” x 3.48” (101.60 x 88.39 mm)
 Main Bearings Caps: Cast Iron GM232-M
 Ignition: Customer Supplied
 Intake Manifold: 4 Barrel (Vortec Style)
 Block MFG.: GM Powertrain
 Flywheel Dia.: 14” (Ring Gear Towards Engine)
 Firing Order: 1 - 8 - 4 - 3 - 6 - 5 - 7 - 2
 Oil Pan Capacity: 5.5 Quarts (With Filter)
 Oil Type: SAE 15W40 Pennzoil Marine
 Horsepower: 310 H.P. @ 4800 RPM (Carburetor)
 Torque: 370 lb-ft @ 3200 RPM
 Warranty: 1 Year Limited (90 Days Commercial)

Note: Actual power levels may vary depending on Quest’s calibration and application.

Available Options:

- Reverse (Right Hand) Rotation Order Part # 042000
- A full range of new replacement parts needed to complete the build up!
- 12 3/4” Flywheel Order Part # 24-14088650

The Quest “Enhanced Base” fuel and spark is brand new and the perfect engine for the boater who requires a new power plant in their boat. This engine is an excellent replacement for customer who has existing components they want to re-install to get their boat back in the water!

Please Call about our full line of Transmissions!



Toll Free: 1-866-255-9265
www.barrmarine.net



NEW!!

5.7L GM “Bobtail” Carbureted Marine Engine Quest Part # 041002A

The Quest 5.7L “Bobtail” engine includes the following (when ordered under the above part number).

The Quest Enhanced Base (part #041000) plus:

Exhaust System (Volvo or MerCruiser)	Coupler (Volvo or MerCruiser)	Alternator
Throttle Linkage	Starter (bottom mount)	Engine Wiring Harness
Fuel/Water Sep. (I/O only)	Weather Cover	Flame Arrestor
Dipstick and Tube	E Z Oil Drain	High Gloss Paint (non-corrosive)
Flywheel Hsg. (where applicable)	Crank Pulley	P/U Pump (when applicable)
	Circ. Pump Pulley	Dust Cover (where applicable)
	Torsion Damper (where applicable)	

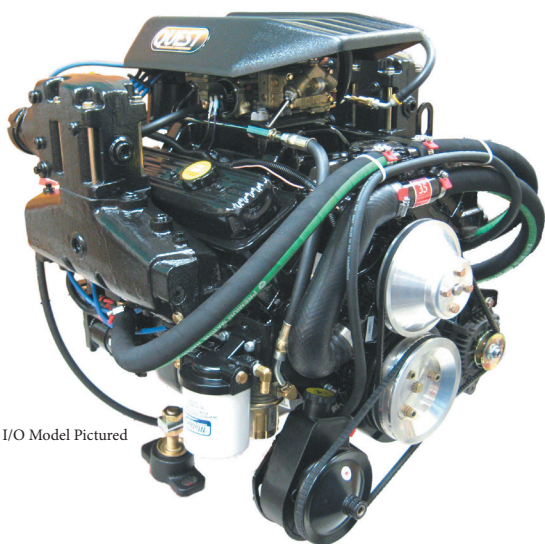

MerCruiser I/O Model Pictured

The “Bobtail” engines by Quest are built only with premium components to insure many years of boating! These super high quality engines have everything factory installed to make sure your customer’s complete engine replacement is a smooth transaction!

Please give the folks at Barr Marine By EDM or one of our very fine engine distributors a call and we will be glad to help you get started breathing life back into your boat!

- Bobtail Without Exhaust (inboard) Order Part #041002**
- Bobtail With Exhaust (inboard) Order Part #041002A**
- Bobtail MerCruiser I/O Order Part #041002M**
- Bobtail Volvo I/O Order Part #041002VO**
- Bobtail W/O Exhaust RH (inboard) Order Part #042002**
- Bobtail With Exhaust RH (inboard) Order Part #042002A**

Note: Power steering system is shown but must be purchased in addition to the bobtail engine. Fuel / water separator is only included on I/O Bobtails only (at no extra charge).

Available Options:

- Power Steering System (w/ oil cooler)
- Closed Cooling (Half or Full System)
- Top Mounted Starter (LH or RH Rotation)

Please Call about our full line of Transmissions!

2 YEAR WARRANTY!



Toll Free: 1-866-255-9265
www.barrmarine.net



Replacement Block Components and Related Parts For The 5.7L Carbureted Engine

All replacement parts are from only the best manufacturers and are used on our production engines as well!



CR 23 350



551040

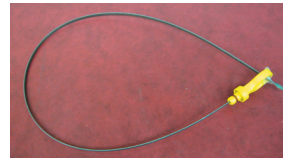

551455



MC 24 44187



MC 24 14043



885016

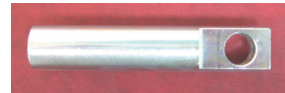

535021



535032

5.7L Block Components

Part Number	Part Description
MC 8 66418	Front Engine Mount (Merc. replacement-in pairs)
885016	Drive Plate (torsion damper)
531009	Flywheel Housing (bottom mount starter)
535033	Splash Plate (bottom mount starter)
531005	Front Engine Mount, RH (to block)
531004	Front Engine Mount, LH (to block)
515003KIT	E Z Drain Oil Kit (metric thread)
551600	Oil Pan Kit
CR 23 350	Oil Pan (Aluminum)
551040	Dipstick Tube
551455	Dipstick
556222	Timing Chain Cover (LH)
556222-OR	Timing Chain Cover (RH)
551654	Cylinder Head Gasket
25 1000	Power Steering Kit
505001	PCV Valve (90 degree type)

Part Number	Part Description
8 0006	Stringer Mount (for #MC 8 66418)
535011	Transmission Mount (for direct drive ZF Trans.)
535015R	Trans. Mount (RH-for reduction and V-Drive ZF)
535015L	Trans. Mount (LH-for reduction and V-Drive ZF)
535021	Trunion (for #531004 & 5)
535032	Stringer Mount (flat)
556000	Valve Cover Kit
551350	Harmonic Balancer
501001	Oil Filter
495121	Remote Oil Filter Kit
551043	Flywheel, Bottom Mount, 14" (1 pc rear seal)
551044	Flywheel, Top Mount, 14" (1 pc rear seal)
24-14088650	Flywheel, Bottom Mount, 12 3/4" (1 pc rear seal)
MC 24 44187	Flywheel Housing (top/bottom mount)
MC 24 14043	Splash Plate (for MC 24 44187)
506002	PCV Valve (straight type)

Note: The Quest Power Steering System is not for sale unless sold as a direct replacement or sold already installed on a Quest bobtail engine! It is recommended that the new Power Steering System is installed on all bobtail engines.



Toll Free: 1-866-255-9265
www.barrmarine.net



Replacement Cooling System and Related Parts For The 5.7L Carbureted Engine

All replacement parts are from only the best manufacturers and are used on our production engines as well!

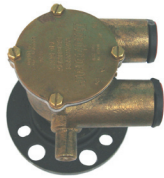

685001



845010



551240



551241



531067



531093

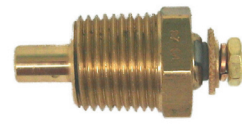

645001



981001

5.7L Cooling System

Part Number	Part Description
981001	Pick Up Pump Bracket (old style)
981108	Pick Up Pump Bracket "A" (new style)
981204	Pick Up Pump Bracket "B" (new style)
685001	Pick Up Pump, Complete (pump only)
685000	Pick Up Pump Rebuild Kit
845010	Hose, Circ. Pump to Thermostat Housing
551240	Single Groove Circ. Pump Pulley
041242	Dual Groove Circ. Pump Pulley
551241	Single Groove Crank Pulley
041494	Dual Groove Crank Pulley
531067	Thermostat Housing (low profile)

Part Number	Part Description
CHV 29 80	Thermostat Housing (Barr style)
531093	1/2" Spacer, T-Stat Housing
986034	Thermostat (drilled for FWC)
MC47 27 53045	Gasket, Intake to Thermostat Housing
551045	Circulation Pump (GM Style)
MC 2 17437	Circulation Pump (Barr style)
MC47 27 34897	Gasket, Circ Pump to Engine
645001	Temperature Sender
531015	Thermostat Housing (Indmar Style)
BA 37 0350	Closed Cooling System (full)
BA 37 0000	Closed Cooling System (half)

Note: See the Barr Marine By EDM catalog for exhaust system options. All "bobtail" engines purchased with exhaust will automatically includes "center rise" exhaust systems ONLY! Log style exhaust system may be used in place of at an additional cost to the engine package.



Toll Free: 1-866-255-9265
www.barrmarine.net



Replacement Electrical System and Related Parts For The 5.7L Carbureted Engine

All replacement parts are from only the best manufacturers and are used on our production engines as well!



986108



573001



575010

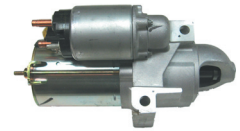

571006



986238



801059



556083



801012

5.7L Electrical System

Part Number	Part Description
556161	Spark Plug
571006	Bottom Mount Starter
551306	Starter Bolt (single, bottom mount)
805061	Starter Relay (carbureted)
755001	Starter Solenoid (bottom mount)
575003	Starter Solenoid (top mount)
573001	Top Mount Starter (LH)
575001	Top Mount Starter (RH)
575010	Alternator (70 AMP)
986108	Alternator Bracket (rear)
986238	Alternator Bracket (front)
725018	Alternator Belt (vee)
801059	Wire Harness

Part Number	Part Description
556096	Ignition Module
556051	Relay, Ignition and Fuel Pump
556084	Rotor (distributor)
556194	Pick Up Coil (distributor)
551006	Clamp, Distributor
551037	Clamp Bolt, Distributor
550002	Distributor Kit
80 473037	Wire Harness Adaptor (cannon style to square)
801012	Timing Shunt
986045	Lifting Eye (single)
805012	Spacer For Wire Harness
556083	Distributor Cap



Toll Free: 1-866-255-9265
www.barrmarine.net



Replacement Fuel System and Related Parts For The 5.7L Carbureted Engine

All replacement parts are from only the best manufacturers and are used on our production engines as well!



525006



781003



981076



695002

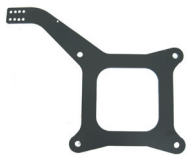

MC 45 0001



841010



611034



531170

5.7L Fuel System

Part Number	Part Description
525006	Flame Arrestor w/ Vent Tube for 3/8" I.D. Hose
781003	F-Line (fuel line to carburetor fitting)
496007	Fuel Pump Safety Switch
981076	Fuel Line (pump to carburetor)
605006	90 Degree Fuel Fitting (line in)
601008	Inverted Flare Fuel Fitting (pump to fuel line)
556099	Intake Gasket
531170	Intake Manifold, 4 brl. (alm. w/ bronze cross-over)
N/A (call)	Intake Manifold, 4 barrel (cast iron)
611031	Carburetor Gasket (Holley-thick)

Part Number	Part Description
695002	Throttle Cable Clip
500001	Electronic Fuel Pump Kit
986024	Rosette Knob (for flame arrestor)
611034	Carburetor (600 CFM/4 barrel)
611015	Carburetor Repair Kit (for # 611034)
BA 45 KIT	Fuel/Water Separator Kit
MC 45 0001	Throttle Bracket (universal Holley style)
496002	Carburetor Wedge Kit
841010	Vent Hose (valve cover to flame arrestor)
981089	Throttle Bracket (Indmar style)

BARR
MARINE BY EDM

Toll Free: 1-866-255-9265
www.barrmarine.net



NEW!!
5.7L GM “Bobtail” MPI Marine Engine
Quest Part # 041003A

The Quest 5.7L “Bobtail” engine includes the following (when ordered under the above part number).

- | | | |
|--------------------------------------|-----------------------------------|----------------------------------|
| Exhaust System (Volvo or MerCruiser) | Coupler (Volvo or MerCruiser) | Alternator |
| Throttle Linkage | Starter (bottom mount) | Engine Wiring Harness |
| Fuel/Water Sep. (I/O only) | E Z Oil Drain | High Gloss Paint (non-corrosive) |
| Crank Pulley | Circ. Pump Pulley | Dipstick and Tube |
| Flywheel Hsg. (where applicable) | Torsion Damper (where applicable) | Dust Cover (where applicable) |



MerCruiser I/O Model Pictured

The “Bobtail” engines by Quest are built only with premium components to insure many years of boating! These super high quality engines have everything factory installed to make sure your customer’s complete engine replacement is a smooth transaction!

Please give the folks at Barr Marine By EDM or one of our very fine engine distributors a call and we will be glad to help you get started breathing life back into your boat!

- Bobtail Without Exhaust (inboard) Order Part #041003**
- Bobtail With Exhaust (inboard) Order Part #041003A**
- Bobtail MerCruiser I/O Order Part #041003M**
- Bobtail Volvo I/O Order Part #041003VO**
- Bobtail W/O Exhaust RH (inboard) Order Part #042003**
- Bobtail With Exhaust RH (inboard) Order Part #042003A**

Note: Power steering system is shown but must be purchased in addition to the bobtail engine. Fuel / water separator is only included on I/O Bobtails only (at no extra charge).

Available Options:

- Power Steering System (w/ oil cooler)
- Closed Cooling (Half or Full System)
- Top Mounted Starter (LH or RH Rotation)

Please Call about our full line of Transmissions!

2 YEAR WARRANTY!



Toll Free: 1-866-255-9265
www.barrmarine.net



Replacement Block Components and Related Parts For The 5.7L MPI Engine

All replacement parts are from only the best manufacturers and are used on our production engines as well!



551044



551040



551455



MC 24 44187



MC 24 14043

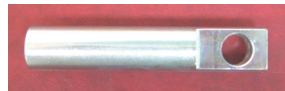

535021



885016



535032

5.7L Block Components

Part Number	Part Description
MC 8 66418	Front Engine Mount (Merc. replacement-in pairs)
885016	Drive Plate (torsion damper)
531009	Flywheel Housing (bottom mount starter)
535033	Splash Plate (bottom mount starter)
531005	Front Engine Mount, RH (to block)
531004	Front Engine Mount, LH (to block)
515003KIT	E Z Drain Oil Kit (metric thread)
551600	Oil Pan Kit
CR 23 350	Oil Pan (Aluminum)
551040	Dipstick Tube
551455	Dipstick
556222	Timing Chain Cover (LH)
556222-OR	Timing Chain Cover (RH)
551654	Cylinder Head Gasket
25 1000	Power Steering Kit
551379	Oil Pressure Sensor (digital)

Part Number	Part Description
8 0006	Stringer Mount (for #MC 8 66418)
535011	Transmission Mount (for direct drive ZF Trans.)
535015R	Trans. Mount (RH-for reduction and V-Drive ZF)
535015L	Trans. Mount (LH-for reduction and V-Drive ZF)
535021	Trunion (for #531004 & 5)
535032	Stringer Mount (flat)
556000	Valve Cover Kit
556293	Crank Position Sensor
501001	Oil Filter
495121	Remote Oil Filter Kit
551043	Flywheel, Bottom Mount, 14" (1 pc rear seal)
551044	Flywheel, Top Mount, 14" (1 pc rear seal)
551350	Harmonic Balancer
MC 24 44187	Flywheel Housing (top/bottom mount)
MC 24 14043	Splash Plate (for MC 24 44187)
556102	MAP Sensor

Note: The Quest Power Steering System is not for sale unless sold as a direct replacement or sold already installed on a Quest bobtail engine! It is recommended that the new Power Steering System is installed on all bobtail engines.



Toll Free: 1-866-255-9265
www.barrmarine.net



Replacement Cooling System and Related Parts For The 5.7L MPI Engine

All replacement parts are from only the best manufacturers and are used on our production engines as well!



685001



981108



981204

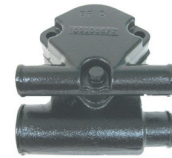

531067



845010



041242



041494



531015

5.7L Cooling System

Part Number	Part Description
981001	Pick Up Pump Bracket (old style)
981108	Pick Up Pump Bracket "A" (new style)
981204	Pick Up Pump Bracket "B" (new style)
685001	Pick Up Pump, Complete (pump only)
685001	Pick Up Pump Rebuild Kit
845010	Hose, Circ. Pump to Thermostat Housing
551240	Single Groove Circ. Pump Pulley
041242	Dual Groove Circ. Pump Pulley
551241	Single Groove Crank Pulley
041494	Dual Groove Crank Pulley
531067	Thermostat Housing (low profile)
556013	Coolant Temperature Sender

Part Number	Part Description
CHV 29 80	Thermostat Housing (Barr style)
531093	1/2" Spacer, T-Stat Housing
986034	Thermostat (drilled for FWC)
MC47 27 53045	Gasket, Intake to Thermostat Housing
551045	Circulation Pump (GM Style)
MC 2 17437	Circulation Pump (Barr style)
MC47 27 34897	Gasket, Circ Pump to Engine
645001	Temperature Sender
531015	Thermostat Housing (Indmar Style)
BA 37 0350	Closed Cooling System (full)
BA 37 0000	Closed Cooling System (half)

Note: See the Barr Marine By EDM catalog for exhaust system options. All "bobtail" engines purchased with exhaust will automatically includes "center rise" exhaust systems ONLY! Log style exhaust system may be used in place of at an additional cost to the engine package.

BARR
MARINE BY EDM

Toll Free: 1-866-255-9265
www.barrmarine.net



Replacement Electrical System and Related Parts For The 5.7L MPI Engine

All replacement parts are from only the best manufacturers and are used on our production engines as well!

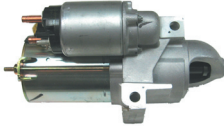

571006



573001



575010



556096



556083



80 473037

5.7L Electrical System(MPI)

Part Number	Part Description
556199	Spark Plug
571006	Bottom Mount Starter
551306	Starter Bolt (single, bottom mount)
986045	Lifting Eye (single)
755001	Starter Solenoid (top mount)
575003	Starter Solenoid (bottom mount)
573001	Top Mount Starter (LH)
575001	Top Mount Starter (RH)
575010	Alternator (70 AMP)

Part Number	Part Description
556096	Ignition Module
556084	Rotor (distributor)
556194	Pick Up Coil (distributor)
551006	Clamp, Distributor
551037	Clamp Bolt, Distributor
80 473037	Wire Harness Adaptor (cannon style to square)
986108	Alternator Bracket (rear)
986238	Alternator Bracket (front)
724018	Alternator Belt (vee)



Toll Free: 1-866-255-9265
www.barrmarine.net



Replacement Fuel System and Related Parts For The 5.7L MPI Engine

All replacement parts are from only the best manufacturers and are used on our production engines as well!



521119



811127

5.7L Fuel System (MPI)

Part Number	Part Description	Part Number	Part Description
521119	Flame Arrestor For MPI Engine	556014	Fuel Pump (w/ return line to tank)
556099	Intake Gasket	556114	Throttle Body Gasket
531125	Intake Manifold (PFI)	636125	Fuel Pressure Regulator (4 bar)
506002	PCV Valve (straight type)	556049	Fuel Injector
505001	PCV Valve (90 degree type)	556104	IAC Valve
811127	Hose, Vent To Flame Arrestor	556103	Throttle Position Sensor



Toll Free: 1-866-255-9265
www.barrmarine.net



NEW!!

5.8L Ford Base (H.O./GT 40 Heads) Marine Engine Quest Part # 092011N

The Quest 5.8L new base engine includes the following (when ordered under the above part number).

Block (with all internal engine components)
Water Circulating Pump
Oil Pan

Harmonic Balancer
Timing Chain Cover
Intake Manifold (4 brl/cast iron)

Valve Covers
Spark Plugs
Flywheel

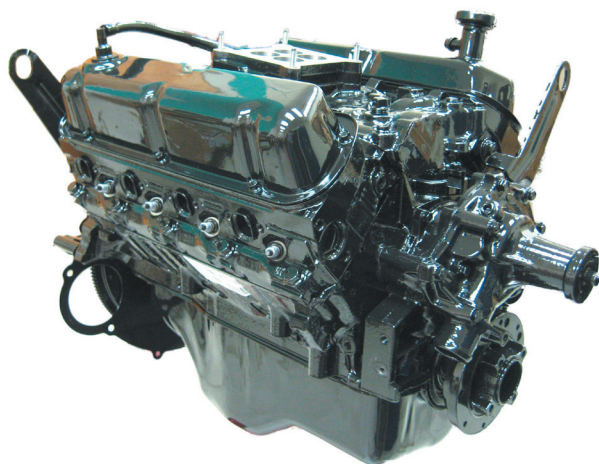

Specifications

Displacement:	351 C.I.D. / 5.8L
Cylinders:	90 Degree V8 Cylinder
Comp. Ratio:	8.3:1
Bore x Stroke:	4.00" x 3.50"
Ignition:	Customer Supplied
Intake Manifold:	Cast Iron (4 Barrel Carburetor)
Block MFG.:	Ford Motor Company
Flywheel Dia.:	14" (Ring Gear Towards Engine)
Firing Order:	1 -3 -7 - 2- 6 -5 - 4 - 8
Oil Type:	SAE 15W40 Pennzoil Marine
Base Timing:	8 degrees BTDC
Electrical System:	12 Volts DC Negative Ground
Operating Range at WOT:	4200-4400 RPM
Oil Capacity:	5 Quarts - Add 1 quart with filter change
Warranty:	1 Year Limited (90 Days Commercial)

Note: The new Ford Engine may be fitted with Ford's marine EFI intake as well!

Available Parts:

- Holley Carburetor (4 barrel) Order Part # 612004
- Electronic Distributor Order Part # 752002
- Starter (new style) Order Part # 592007
- Dipstick Order Part # 592016
- Dipstick Tube Order Part #592017
- Crank Pulley (2 groove) Order Part # 594208
- Circ. Pump Pulley (2 groove) Order Part # 594209

The Quest "351 Base" engine is brand new and the perfect engine for the boater who requires a new power plant in their boat. This engine is an excellent replacement for customer who has existing components they want to re-install to get their boat back in the water!



Toll Free: 1-866-255-9265
www.barrmarine.net



NEW!!

6.0L GM “Green” Base Marine Engine

Quest Part # 051022G

The Quest 6.0L new “Green” base engine includes the following (when ordered under the above part number).

Block (with all internal engine components)
 Water Circulating Pump
 Stock Flywheel
 Ignition System (coil near plug)
 Dip Stick Tube

Crank Pulley
 Circ. Pump Pulley
 Fuel System (GM supplied only)
 Water Circlating Pump
 Electronic Throttle Body

Valve Covers
 Spark Plugs
 Oil Pan
 Dip Stick

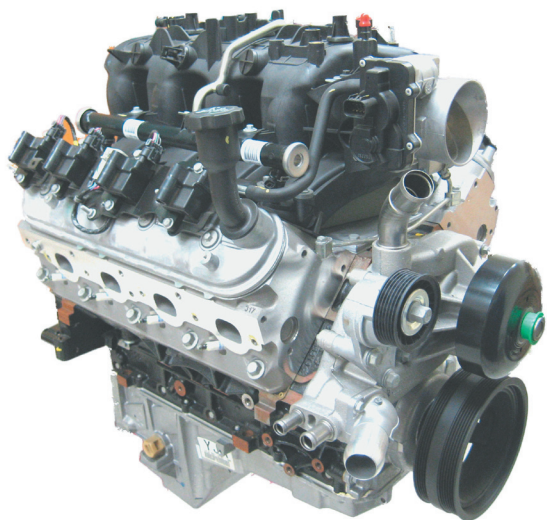

Specifications

Displacement:	364 C.I.D. (5967 CC) / 6.0L
Type:	6000 V-8
Comp. Ratio:	10.1:1
Valve Config.:	Overhead Valves (2 valves per cylinder)
Valve Lifters:	Hydraulic Roller
Bore x Stroke:	101.60 x 92 mm
Main Bearings Caps	Powder Metal
Fuel System:	Port Fuel Injection
Fuel Type:	Regular Unleaded
Fuel Shutoff:	5900 to 6000 RPM
Emmision Controls.:	Positive Crankcase Vent./Returnless Fuel System
Firing Order:	1 - 8 - 7 - 2 - 6 - 5 - 4 - 3
Horsepower:	380 H.P. @ 5200 RPM
Torque:	409 lb-ft @ 4200 RPM
Warranty:	1 Year Limited (90 Days Commercial)

Note: Actual power levels may vary depending on Quest’s calibration and application.

The new Vortec 6000 Marine Engine is sold through Quest exactly the way GM builds the engine for us.

The 6.0L “Green” base engine features an electronic throttle body, coil near plug ignition, a cylinder head inspired by the LS6 Corvette engine and many more features that will make this the perfect direct replacement for any boater!

(Note: The LQ-9/6.0L uses a MEFI 5 ECM)

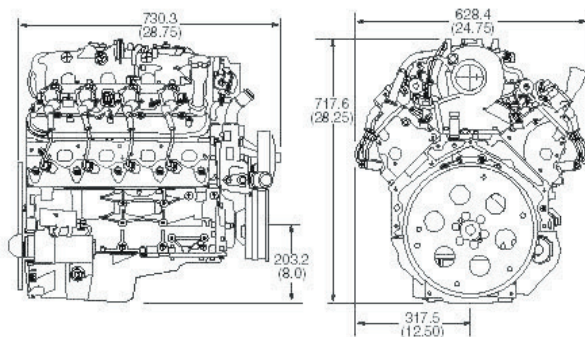

Toll Free: 1-866-255-9265
www.barrmarine.net



NEW!!

7.4L GM (H.O./390 H.P) Long Block Marine Engine Quest Part # 051014N

The Quest 7.4L new "Long Block" engine includes the following (when ordered under the above part number).

Block (with all internal engine components)
Timing Chain Cover

Harmonic Balancer
Oil Pan

Valve Covers

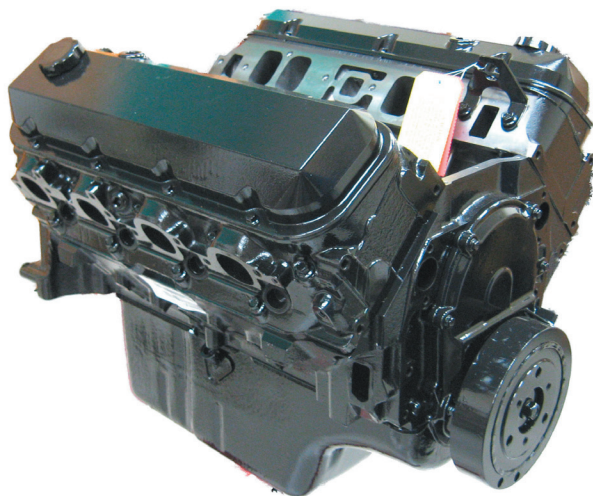

Specifications

Displacement:	454 C.I.D. / 7.4L
Cylinders:	90 Degree V8 Cylinder
Comp. Ratio:	8.6:1
Valve Config.:	Overhead Valves (2 valves per cylinder)
Valve Lifters:	Hydraulic Roller
Ignition:	Customer Supplied
Intake Manifold:	Customer Supplied
Block MFG.:	GM Powertrain
Flywheel Dia.:	Customer Supplied
Firing Order:	1 - 8 - 4 - 3 - 6 - 5 - 7 - 2
Oil Pan Capacity:	8 Quarts (With Filter)
Oil Type:	SAE 15W40 Pennzoil Marine
Warranty:	1 Year Limited (90 Days Commercial)

Note: Actual power levels may vary depending on Quest's calibration and application.

The Quest "Long Block" engine is brand new and the perfect engine for the boater who requires a new power plant in their boat. This engine is an excellent replacement for customer who has existing components they want to re-install to get their boat back in the water!

Please Call about our full line of Transmissions!



Toll Free: 1-866-255-9265
www.barrmarine.net



NEW!!

8.1L GM “EFI Base” Marine Engine

Quest Part # 051018N

The Quest 8.1L new “EFI Base” engine includes the following (when ordered under the above part number).

Block (with all internal engine components)
 Water Circulating Pump
 14” Flywheel
 GM Installed EFI (coil near plug ignition)

Harmonic Balancer
 Timing Chain Cover
 Oil Pan
 EFI Intake

Valve Covers
 Spark Plugs
 Plug Wires
 High Gloss Paint (non-corrosive)



8.1L Bobtail Pictured (part #041004)

Specifications	
Displacement:	496 C.I.D. (8128 CC) / 8.1L
Cylinders:	90 Degree V8 Cylinder
Comp. Ratio:	9.1:1
Valve Config.:	Overhead Valves (2 valves per cylinder)
Valve Lifters:	Hydraulic Roller
Bore x Stroke:	4.25” x 4.37” (107.95 x 111 mm)
Main Bearings Caps:	Cast Nodular Iron
Ignition:	GM Installed “Coil Near Plug”
Intake Manifold:	EFI Intake / GM Installed
Block MFG.:	GM Powertrain
Flywheel Dia.:	14” (Ring Gear Towards Engine)
Firing Order:	1 - 8 - 7 - 2 - 6 - 5 - 4 - 3
Oil Pan Capacity:	10 Quarts
Oil Type:	SAE 15W40 Pennzoil Marine
Paint Protectant:	High Gloss Black / Superior Corrosion Resistant
Horsepower:	419 H.P. @ 5000 RPM
Torque:	503 lb-ft @ 4000 RPM
Warranty:	1 Year Limited (90 Days Commercial)

Note: Actual power levels may vary depending on Quest’s calibration and application.

Note: Some parts Shown in this above picture are NOT part of the “Base” build up (bobtail pictured).

Available Options:

-Hi Output Version Order Part # 051017N

Please Call about our full line of Transmissions!

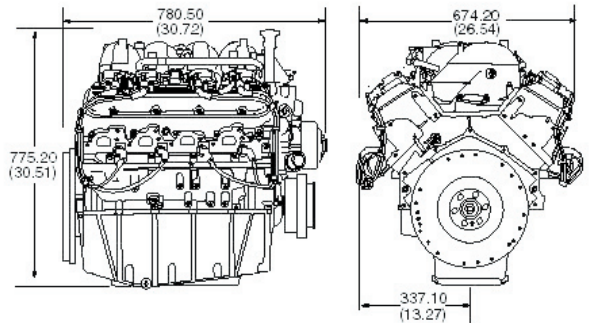

Toll Free: 1-866-255-9265
www.barrmarine.net



NEW!!

8.1L GM “Bobtail” MPI Marine Engine Quest Part # 041004A

The Quest 8.1L “Bobtail” engine includes the following (when ordered under the above part number).

The Quest Enhanced Base (part #051018N) plus:

- | | | |
|---|-----------------------------|-------------------|
| Exhaust System (Choice of Center Rise System) | Alternator | Throttle Linkage |
| Starter (bottom mount) | Engine Wiring Harness | Flame Arrestor |
| Weather Cover | E Z Oil Drain | Dipstick and Tube |
| Remote Oil Filter | Flywheel Housing/Dust Cover | Torsional Damper |
| | | P/U Pump |



8.1L Bobtail Pictured (part #041004)

The “Bobtail” engines by Quest are built only with premium components to insure many years of boating! These super high quality engines have everything factory installed to make sure your customer’s complete engine replacement is a smooth transaction!

Please give the folks at Barr Marine By EDM or one of our very fine engine distributors a call and we will be glad to help you get started breathing life back into your boat!

Bobtail Without Exhaust (inboard) Order Part #041004

The 8.1L can only be built for an inboard application (no I/O’s).

Note: 3 inch spacer blocks must be used when installing the MerCruiser center rise exhaust (spacer # MC 20 93320A3 (spacers will be sold at an additional cost to the package).

Available Options:

-Closed Cooling (Half System only)

Please Call about our full line of Transmissions!

2 YEAR WARRANTY!



Toll Free: 1-866-255-9265
www.barrmarine.net



Quest Engine Parts KITS

All replacement parts are from only the best manufacturers and are used on our production engines as well!

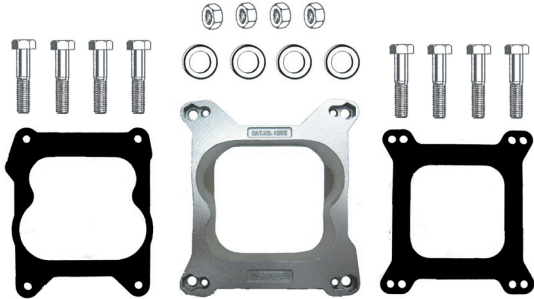

BA 45 1932

Spread Bore to Square Bore Carburetor Adaptor

BA 45 1932 is used on the 4.3L Quest Engine but may be used anywhere a 4 barrel spread bore to square bore carburetor conversion is needed!



BA 45 KIT

Fuel/Water Separator Kit for 4.3L and 5.7L Carbureted Engines

BA 45 KIT is included on all Bobtail 4.3L and 5.7L Quest I/O carbureted engine and a great option for any other 4.3L or 5.7L bobtail engine!

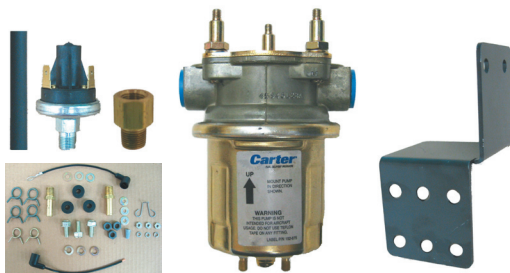

500001

Electronic Fuel Pump Kit

500001 Fuel Pump Kit may be used on any 4.3L and 5.7L Enhanced Base or Bobtail. This kit is installed on all Enhanced Base and Bobtail 4.3L and 5.7L Quest Carbureted Engines!

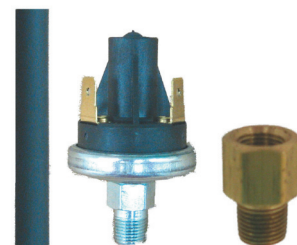

496007

Fuel Pump Safety Switch Kit

496007 F/P safety switch kit may be used on any 4.3L and 5.7L Enhanced Base or Bobtail. This kit is installed on all Enhanced Base and Bobtail 4.3L and 5.7L Quest Carbureted Engines!

BARR
MARINE BY EDM

Toll Free: 1-866-255-9265

www.barrmarine.net



Quest Engine Parts KITS (continued)

All replacement parts are from only the best manufacturers and are used on our production engines as well!



550002

5.7L Complete Distributor Kit

550002 is used on the 5.7L Quest Engine and may be used anywhere an electronic ignition conversion is desired!

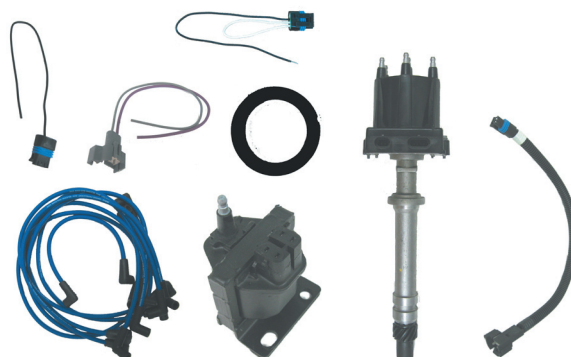

550003

4.3L Complete Distributor Kit

550003 is used on the 4.3L Quest Engine and may be used anywhere an electronic ignition conversion is desired!

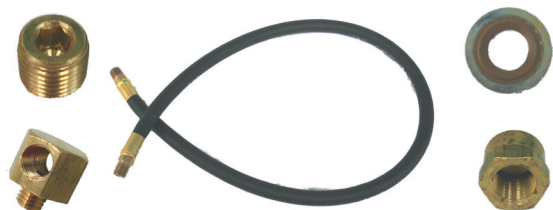

515003 KIT

4.3L and 5.7L Bobtail E-Z Drain Oil Kit

515003 KIT is used on the 4.3L and 5.7L Bobtail Engines and may be used anywhere an E-Z Oil Drain is needed!
Note: This kit is used for Metric Thread oil pans only.

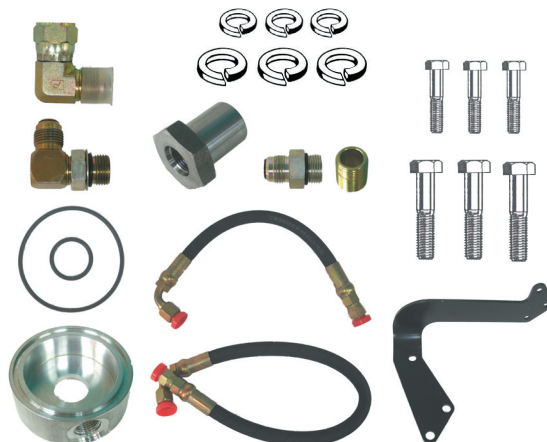

495121

4.3L and 5.7L Remote Oil filter Kit

495121 is used on the 4.3L and 5.7L Bobtail Engines and may be used anywhere an Remote Oil Filter Kit is desired!

BARR
 MARINE BY EDM

Toll Free: 1-866-255-9265

www.barrmarine.net



Quest Engine Parts KITS

All replacement parts are from only the best manufacturers and are used on our production engines as well!

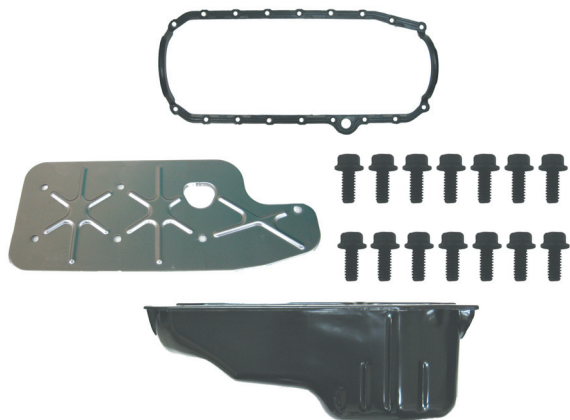

551600

Quest 5.7L Steel Oil Pan Kit

551600 KIT is used on the 5.7L Engines and may be used anywhere a steel oil pan replacement is needed!

Note: This kit is used for one piece seal engines only!



556000

Quest 5.7L Valve Cover Kit

556000 KIT is used on the 5.7L Engines and may be used anywhere a valve cover replacement is needed!

Note: This kit replaces the "center bolt" valve covers only!



997422U (USB port)

997422S (serial port)

Quest-Diacom Scan Tool MEFI 5 Kit

This DIACOM Software Kit can be used on all engines with MEFI 1 thru MEFI 5 systems installed!



685000

Quest Pick Up Pump Rebuild Kit

685000 KIT is used on the 4.3L, 5.7L and 8.1L Engines and may be used anywhere a valve cover replacement is needed!

BARR
MARINE BY EDM

Toll Free: 1-866-255-9265

www.barrmarine.net



Quest Closed Cooling KITS (5.7L & 4.3L Half and Full Systems)

All replacement parts are from only the best manufacturers and are used on our production engines as well!



BA 37 0000

5.7L & 4.3L Closed Cooling Half System

This FWC Half kit may be installed on any 5.7L bobtail Quest Engine (front mount only)



BA 37 0350

5.7L & 4.3L Closed Cooling Full System

This FWC Full kit may be installed on any 5.7L bobtail Quest Engine (front mount only)

BARR
MARINE BY EDM

Toll Free: 1-866-255-9265

www.barrmarine.net