



## Control Panel

Very compact 86x124mm (3.84x4.9 in) and featuring a shielded connecting cable 10mts (32.8 ft) long.

Manufactured according to the latest technologies, it features a microprocessor based design. The polystyrene shockproof keyboard with IP54 protection grade contains:

- Digital hour-meter.
- ON/START/OFF controls.
- Low oil pressure warning light.
- High engine / alternator temperature warning lights and cutout.

## Engine

- One side serviceability of injection and lubrication system, sea water pump and air cleaner.
- Low oil pressure cutout.
- High exhaust temperature cutout.
- Double vibration dumping system.
- Oil filter.
- Easy access to the disposable oil filter.
- Oil drain pump.

## Alternator

- Synchronous, 2 poles, brush less self-excited.
- Rotor and stator epoxy resin coated against external agents.
- Windings high temperature protection.
- Insulation class H.

## Soundproof cabin

A new project engineering design with a structure of a draw piece of aluminum supporting, painted aluminum panels type 5754 of high resistance to external agents.

Of limited weight and easy accessibility to the inner cabin in case of maintenance services.

## THE INTERCOOLER W/A

It cools the air inside the sound proof box so that the engine as well as the alternator work at the ideal temperature, independently of the outside ambient conditions. By means of intercooler W/A generating set performances and reliability are always at their best.

Engine	50 Hz	60Hz
Model	Yanmar L100AE	
Type	Diesel, 4-stroke	
Cylinders (nr.)	1	
Cylinder block material	Aluminium	
Bore (mm. - in.)	86 - 3.38	
Stroke (mm. - in.)	70 - 2.75	
Displacement (cc. - CID)	406 - 24.8	
Power (hp)	8.8	10
RPM	3000	3600
Compression ratio	20:1	
Combustion system	Direct injection	
Engine head material	Aluminium	
Speed governor	Centrifugal mechanical	
Lubrication system	Forced	
Oil sump capacity with filter (lt. - US qts)	1.65 - 0.36	
Engine stop system	Fuel solenoid	
Fuel pump	Electric	
Fuel pump discharge (cm. - ft)	70 - 2.3	
Fuel consumption (l/h-gal/h )	2.1 - 0.46	2.5 - 0.55
Air intake (l/min. - gal/min.)	550 - 19.4	660 - 23.3
Starting battery (Ah-V)	45 - 12	
Starter (kW-V)	0.8 - 12	
Max. inclination	30°	
Water pump flow (l/min. - gal/min.)	20 - 4.4	

Alternator	50 Hz	60Hz
Type	Brush less synchronous, 2-poles self-excited	
Cooling	Air/water ( Intercooler W/A )	
Voltage (V)	115 - 230	120 - 240
Frequency (Hz)	50	60
Nominal current (A)	43.5 - 21.7	47.5 - 23.7
Max. power (kW)	5	5.7
Continuous power (kW)	4	4.8
Battery charging output (A-V)	10 - 12	
Power factor ( cos ø )	1	
Insulating class	H	
Voltage stability	±10%	
Frequency stability	±5%	

## Cooling system

The cooling system of the engine is based on a heat exchanger ( sea water / air ) with the main function of reducing the temperature of the air flow inside the box. The system provides an efficacious cooling of the alternator and the optimal temperature for the best performance and reliability of the gensets; despite its on board allocation and room temperature.

	50 Hz	60Hz
Dimension (Lenght x Width x Height.)	675x468x565mm - 26.5x18.4x22.2 (in.) (with soundproof box)	
Weight	130 Kg. - 286 (lb) (with soundproof box)	
Noise Level	54 dB <sub>A</sub> at 7mt (23 ft)	56 dB <sub>A</sub> at 7mt (23 ft)

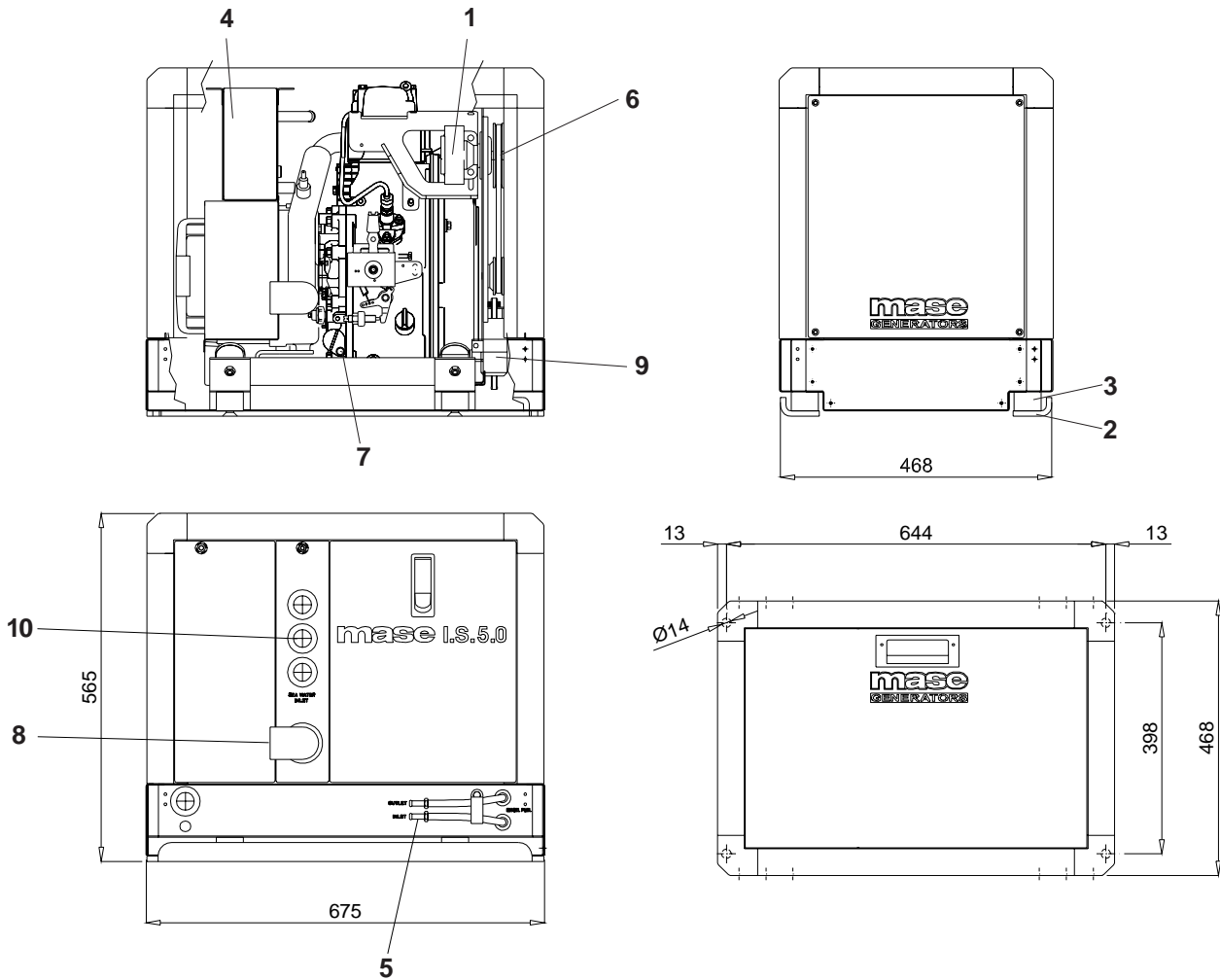

- 1- Sea water pump
- 2 - Genset base bracket
- 3 - Vibromounts
- 4 - Heat exchanger (Intercooler W/A)
- 5 - Fuel tank connection
- 6 - Air cleaner
- 7 - Oil filter
- 8 - Exhaust manifold (ø45 mm)
- 9 - Fuel pump (ø8 mm)
- 10- Connection to sea water intake (ø15 mm)

*This drawing is only a reference and is not indicatly for the installation. For more information, you may contact your local dealer or **mase** generators S.p.A.*

**mase** generators S.p.A. reserves the right to change the design or specifications without notice and without any obligations or liability whatsoever. For more information, you may contact your local **mase** dealer.

## FITTINGS

EXHAUST COMPONENTS KIT  
SIPHON BREAK  
W.G. SEPARATOR KIT

Dealer: