

# Barracuda

## MD170 and MD200

170 Hp @ 3500 Rpm

200 Hp @ 4,000 Rpm



by  
**Performance Product  
Technologies**

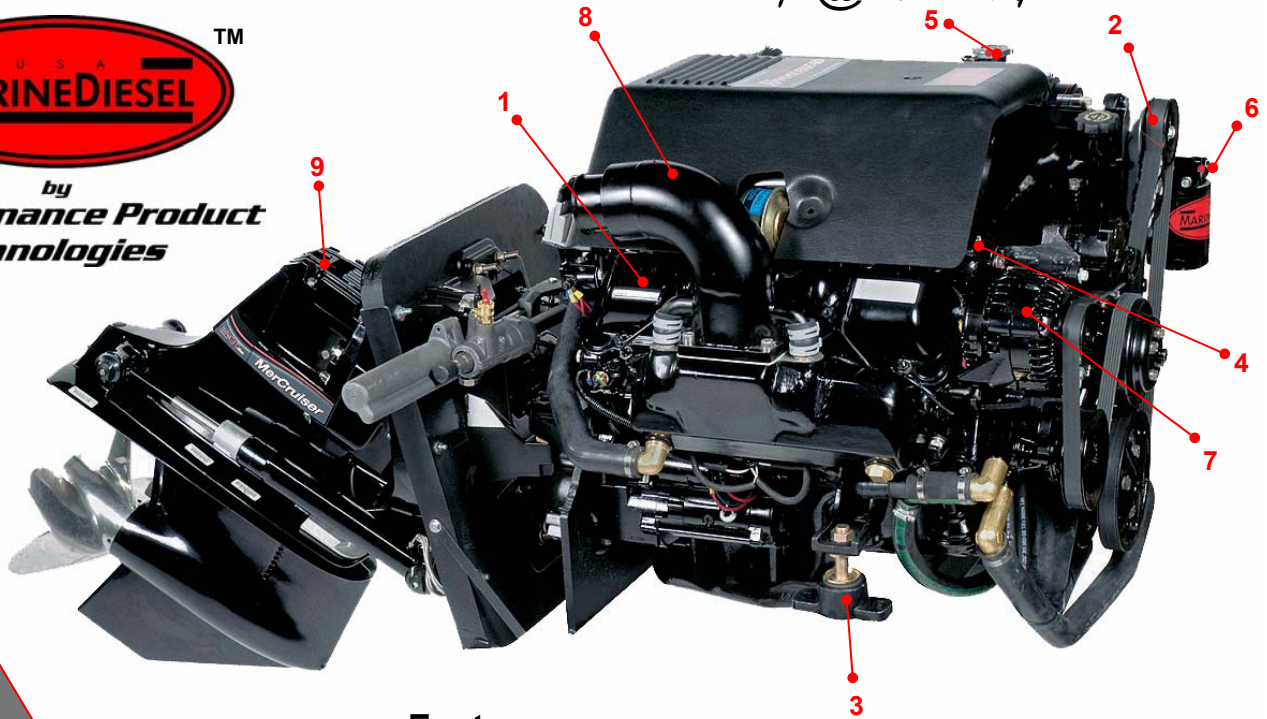

### Features

1. AM General's Optimizer 6500 base engine
2. Smooth running serpentine belt system
3. Engine Mounts & Bellhousing match GM produced small & big block V8 gas engines
4. Standard MerCruiser / Volvo Penta 9-pin electrical harness connector
5. Hi-Capacity Cu-Ni Heat Exchanger
6. Remote Mounted Oil Filter
7. Hi-Output 105 Amp Alternator
8. Powder Coated Stainless Steel Dry-Joint Risers with Performance Tuned Aluminum Manifolds
9. Multiple Drive Options—MerCruiser Diesel X Stern-drives

### MarineDiesel-USA

The MD170 & MD200 Barracuda, when joined with MerCruiser's Diesel-X Series sterndrive provides the marine industry with its most impressive combination of diesel engine & outdrive. Only MarineDiesel offers the rugged durability of the Optimizer 6500 packaged with Merc's impressive new Diesel-X sterndrive.

### Technical Data

Displacement..... 6.5L  
 Configuration..... V-8  
 Rated RPM..... 3500 & 4000  
 Horsepower MD170 ..... 170 @ 3500  
 Horsepower MD200 ..... 200 @ 4000  
 Torque ft. lb. .... 315 @ 1700  
 Bore & Stroke..... 103 X 97mm  
 Compression Ratio..... 18:1  
 Fuel System ..... Indirect Injection  
 Aspiration ..... Natural  
 Alternator ..... 12V, 105amp  
 Cooling ..... Dual pump w Heat Exchanger

### Size

Length ..... 30.7"  
 Width ..... 34"  
 Height ..... 30.7"  
 Weight less drive pkg. .... 904 lbs.  
 Weight with Bravo I pkg..... 1181 lbs.  
 Weight with Bravo II pkg..... 1193 lbs.  
 Weight with Bravo III pkg..... 1202 lbs.

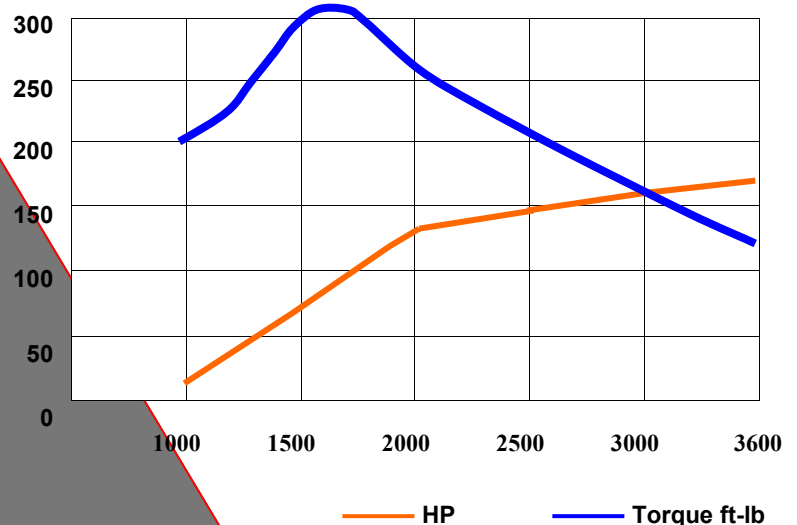

1414 South Sangre Rd.  
Stillwater, OK. 74074

Ph: 405-533-3833 Fax: 405-377-3388

E-mail: [sales@marinedieselusa.com](mailto:sales@marinedieselusa.com)

MD170 & MD200  
 170hp @ 3500  
 200 hp @ 4000

# Barracuda

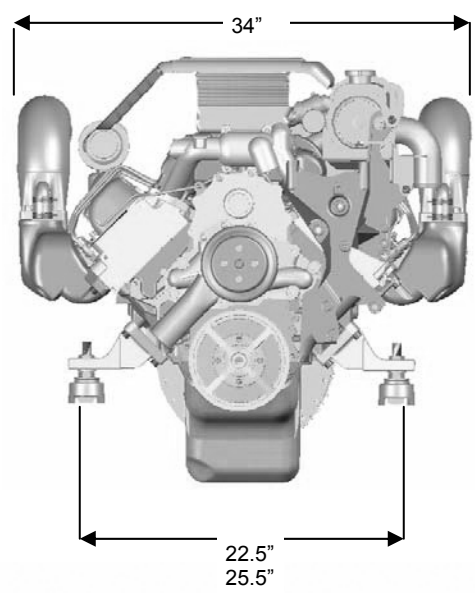

New for 2005 MarineDiesel-USA is proud to announce the addition of the MerCruiser Bravo-X Diesel Series outdrive to our already impressive lineup. The Bravo-X Diesel drives represent a breakthrough in diesel / sterndrive technology and durability.

- The following drive ratio's are available.
- Bravo I..... 1.36 & 1.5:1
  - Bravo II..... 1.65, 1.81 & 2.0:1
  - Bravo III..... 1.5, 1.65 & 1.81:1
  - Jackshaft Kit..... Optional

**Direct Replacement**

When replacing existing GM small or big block V8 gas engines the MarineDiesel will match the existing mounts, flywheel housing, length, width, height and weight to that of existing gas engines, as well as offers a standard 9-pin electrical harness connection to match existing boat harnesses. This allows preserving the original integrity of the boat utilizing mounts, exhaust system, gauges, alarms and tachometers. When comparing competitive products make sure to compare the overall installed engine cost, not just the product cost.

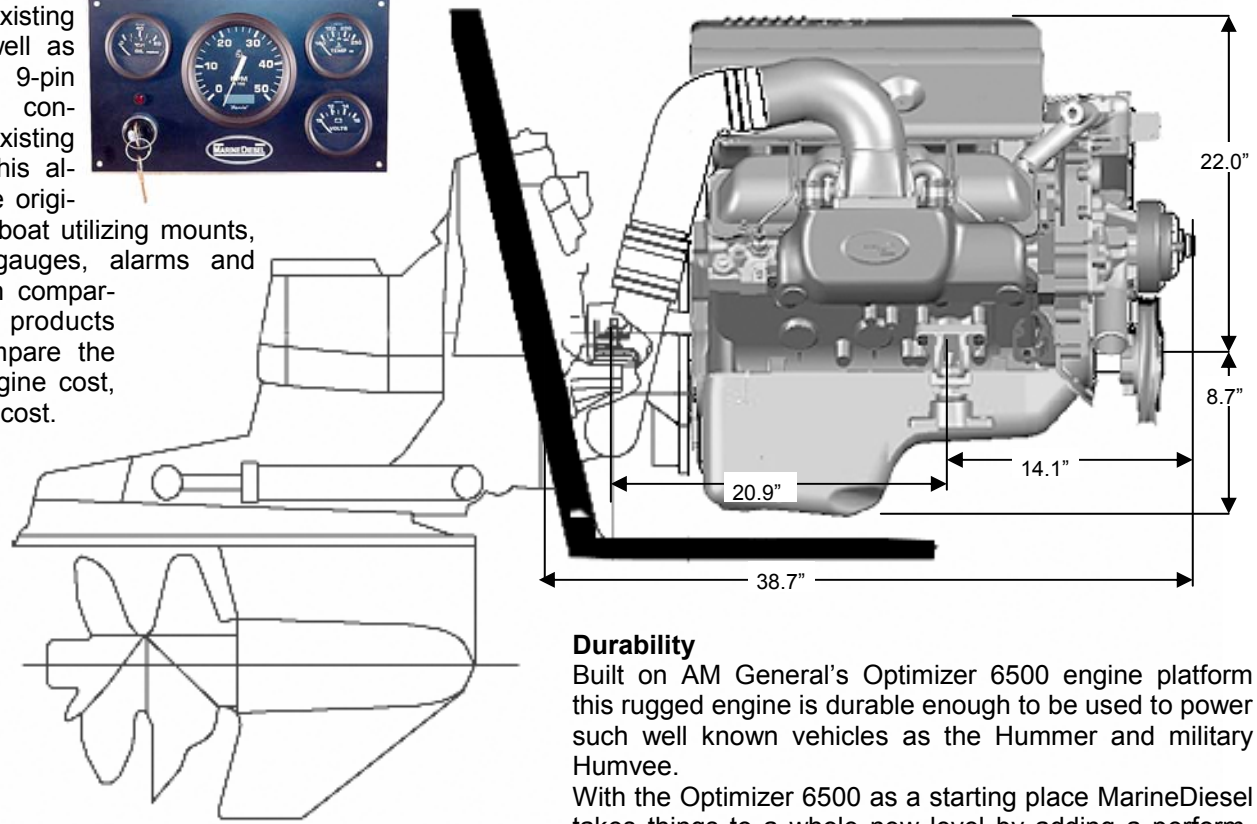

**Performance**

Starting with a 6.5L displacement in a V8 configuration, MarineDiesel achieves superior low rpm torque versus smaller displacement inline engines. The V8 configuration provides a smoother running and longer lasting platform to power your next pleasure or commercial watercraft.

**Durability**

Built on AM General's Optimizer 6500 engine platform this rugged engine is durable enough to be used to power such well known vehicles as the Hummer and military Humvee. With the Optimizer 6500 as a starting place MarineDiesel takes things to a whole new level by adding a performance tuned center riser dry-joint exhaust system with stainless risers, a high capacity fresh water cooling system, 105 amp alternator, oil drain system and fresh water flush kit.

1414 South Sangre Rd.  
 Stillwater, OK. 74074  
 Ph: 405-533-3833 Fax: 405-377-3388  
 E-mail: [sales@marinedieselusa.com](mailto:sales@marinedieselusa.com)

All MarineDiesel engines

