

Circulate to: Sales Manager Accounting Service Manager Technician Parts Manager

▲ = Revised October 2005. This bulletin supercedes the previous bulletin 2004-05 July 2004.

Gen II Cool Fuel Pump Replaced by Pump / Cooler Kits

Situation

The fuel pump for the Gen II Cool Fuel System is no longer available as an individual component. The pump will now be available only as part of a Pump and Cooler Kit, which includes the fuel pump, fuel cooler, and hardware. Three kits will be available, and the applications for each kit are described below.

The various coolers are not interchangeable, therefore, be sure to order the correct kit for the model and serial number of the engine being repaired.

Replacement Kit Selection

861156A02 - Fuel Pump / Cooler Kit With Drain - has fuel cooler (861267), which has an integral water drain port and has a cross bolt to retain the fuel line to the fuel cooler outlet

MCM 496 MAG MPI	ALL
MCM 496 MAG HO MPI	ALL
MIE 8.1s HORIZON	ALL
MIE 8.1s HO	ALL
Black Scorpion Models	0L000000 & up
All other MPI & EFI Models	0L000000 to 0M300000

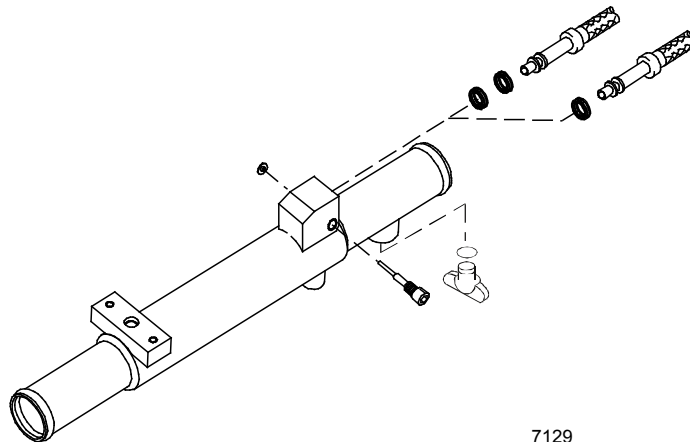

7129

THE INFORMATION IN THIS DOCUMENT IS CONFIDENTIAL AND PROTECTED BY COPYRIGHT AND IS THE PROPERTY OF MERCURY MARINE.

This document is provided for the sole and exclusive use of the original recipient as prescribed by Mercury Marine and may not be distributed or copied, digitally or otherwise, without the prior written consent of Mercury Marine.

861156A03 - Fuel Pump / Cooler Kit Without Drain - has fuel cooler (865356), which is shorter, does not have a water drain port, and has a cross bolt to retain the fuel line to the fuel cooler outlet

MCM 4.3 MPI (Alpha and Bravo)	0M300000 & up
MCM 5.0 MPI	0M300000 & up
MCM 350 MAG MPI	0M300000 & up
MCM MX6.2 MPI	0M300000 & up
MIE 350 MAG MPI	0M300000 & up
MIE MX6.2 MPI	0M300000 & up

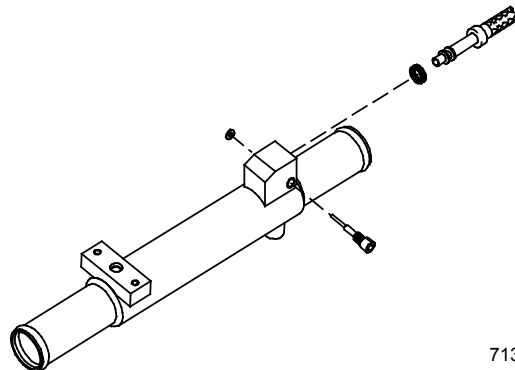

861156A04 - Fuel Pump / Cooler Kit With Drain - has fuel cooler (807950), which has an integral water drain port and has a fuel line retaining bolt that is parallel to the fuel line to attach the fuel line to the fuel cooler outlet

All MPI, EFI, and TBI models with Cool Fuel 0K999999 & lower (▲ Read the following Note.)

NOTE: ▲ Numerous engines with serial number 0K999999 and lower were affected by Service Bulletin 1997-20. Repairs done under this bulletin resulted in a change in the fuel lines and a change in the cooler to the cross-bolt style fuel line attachment. To determine the correct fuel pump and cooler kit on these engines it will be necessary to determine the method of retaining the fuel line on the cooler. If the cooler is original and the fuel line is retained by a bolt on a fuel line flange, use kit 861156A04. If the fuel cooler was replaced and the fuel line is retained by a fuel line retainer screw (cross bolt style), use kit 861156A02.

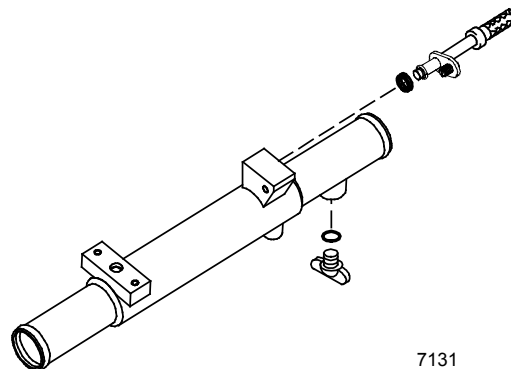

THE INFORMATION IN THIS DOCUMENT IS CONFIDENTIAL AND PROTECTED BY COPYRIGHT AND IS THE PROPERTY OF MERCURY MARINE.

This document is provided for the sole and exclusive use of the original recipient as prescribed by Mercury Marine and may not be distributed or copied, digitally or otherwise, without the prior written consent of Mercury Marine.