

# Specifications

The Series 5000 Down Angle transmission is specifically designed for twin engine applications that require nearly horizontal engine installation. Its full reversing feature eliminates the need for opposite rotating engines, while the 8 degree "down angle" eliminates the problems that result from extremely steep engine installation angle. An improved hydraulic system provides more engine torque to the propeller. New design features such as an hydraulic pump and

control valve make service easier. The control lever and dipstick are centrally located. Additionally, an optional SAE "A" auxiliary pump drive mounting is available on the rear of the Series 5000 transmission. Like all Velvet Drive® marine transmissions, the Series 5000 accepts standard damper assemblies, flywheel housing adapters and propeller shaft couplings.

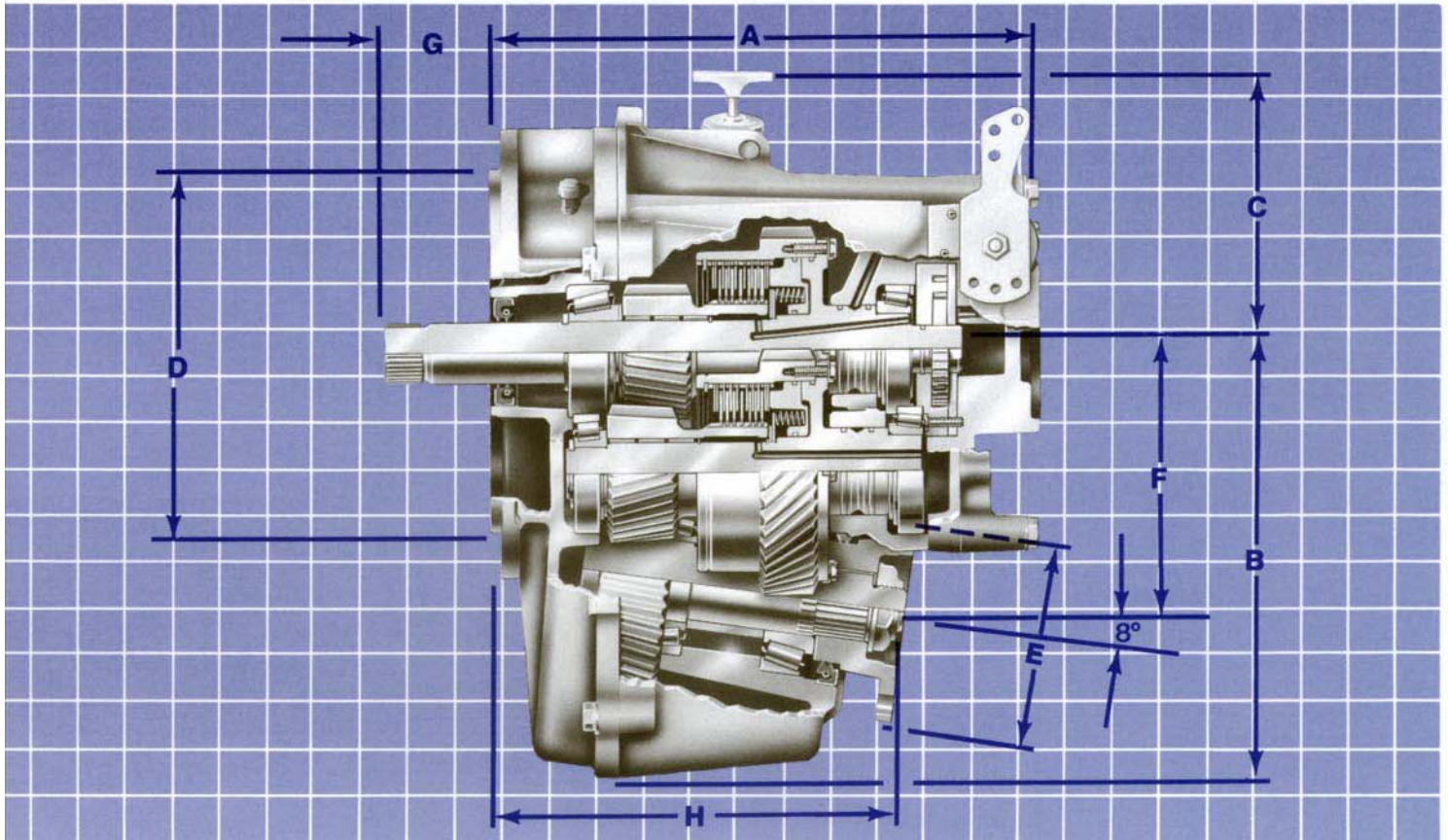

## Dimensions Inches (millimeters)

A	B	C	D	E	F	G	H
12.09 (307.0)	9.78 (248.5)	6.38 (162.0)	8.25 (209.5)	5.00 (127.0)	5.95 (151.2)	2.56 (65.0)	8.98 (228.1)

## General Information (subject to change without notice)

<b>Available Ratios</b> .....	1.05, 1.3, 1.6, 2.0, 2.45, 2.8:1
Both directions of output rotation .....	
<b>Input Shaft Spline Teeth</b> .....	26
<b>Input Shaft Rotation</b> .....	automotive
<b>Output Shaft Rotation</b> .....	either direction
<b>Approximate Dry Weight</b> .....	109 lbs. (49.4 kg)