

Sterndrive Unit Installation

1. Remove trim cylinder support and dust cover from bell housing studs. (Retain elastic stop nuts and flat washers.)
2. Remove gear lube monitor cap. Fill with lubricant.

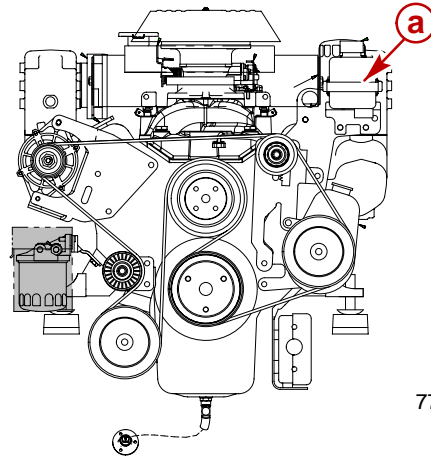

77108

a - Gear Lube Monitor

Description	Where Used	Part Number
A High Performance Gear Lube	Gear Lube Monitor	92-802853A1

3. Push dribble valve stem in until gear lube appears.

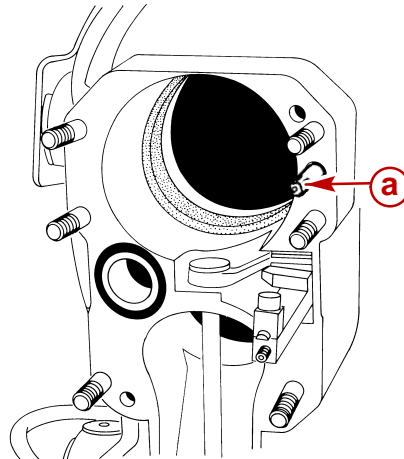

75531

a - Dribble Valve Stem

4. Once gear lube appears, release dribble valve stem.
5. Fill monitor to FULL mark.
6. Replace monitor cap.

IMPORTANT: Rubber gasket must be properly positioned in bell housing bore before installing drive unit or water may leak into boat.

- Alpha Models:** Ensure that rubber gasket and water passage O-ring are properly positioned in bell housing.

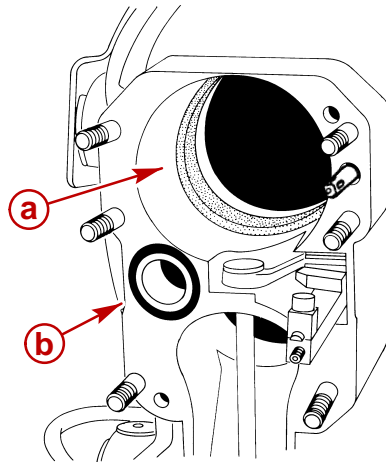

75531

- a** - Rubber Gasket
- b** - Water Passage O-ring

- Coat sterndrive unit pilot, U-joint O-rings and drive shaft splines.

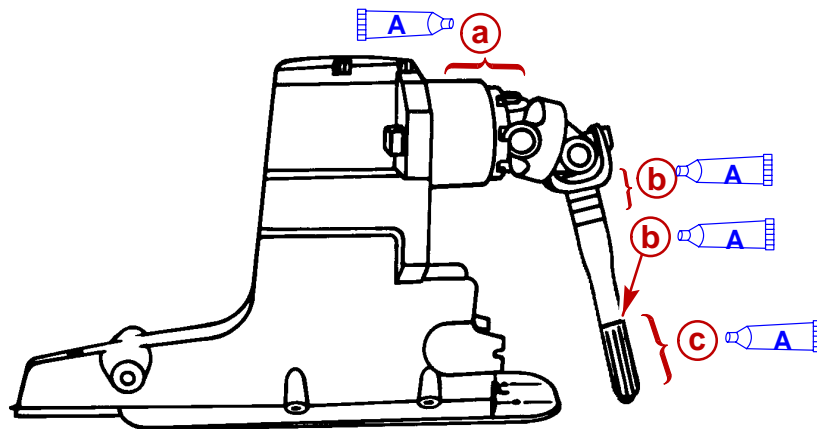

70114

- a** - Sterndrive Unit Pilot
- b** - O-rings
- c** - Splines

Description	Where Used	Part Number
A Engine Coupler Spline Grease	Drive Unit Pilot	92-816391A4
	U-Joint O-rings	
	Drive Shaft Splines	

9. Ensure drive shaft bellows are clean and free of debris.

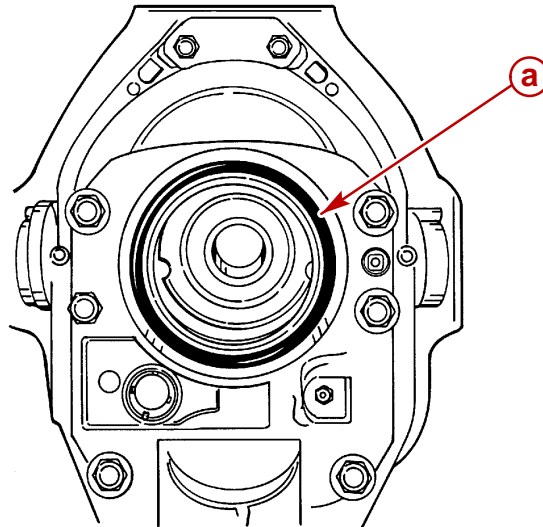

72472

a - Drive Shaft Bellows

Alpha Models

1. Position bell housing shift shaft coupler so that slot in coupler is positioned straight fore and aft. Do this by placing remote control shift lever in: **FORWARD gear position for RH drive or REVERSE gear position for LH drive unit.**

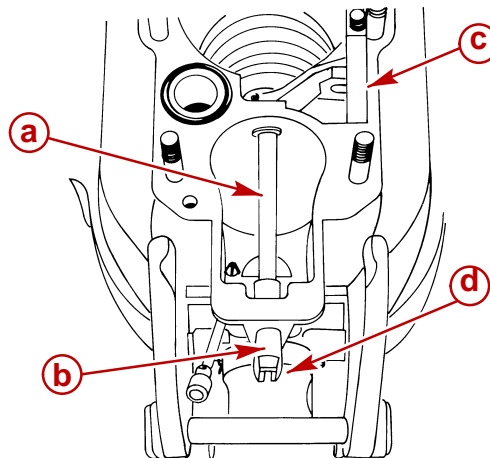

75525

a - Shift Shaft
b - Shift Shaft Coupler
c - Shift Slide
d - Slot

IMPORTANT: Shift slide assembly is free to rotate on core wire. Ensure that shift slide remains in upright position and is properly engaged with shift shaft lever roller while installing drive unit.

- Engage shift shaft roller into shift shaft lever. Snap the Shift Shaft Slide Stabilizer Tool onto stud directly below shift slide and position as shown.

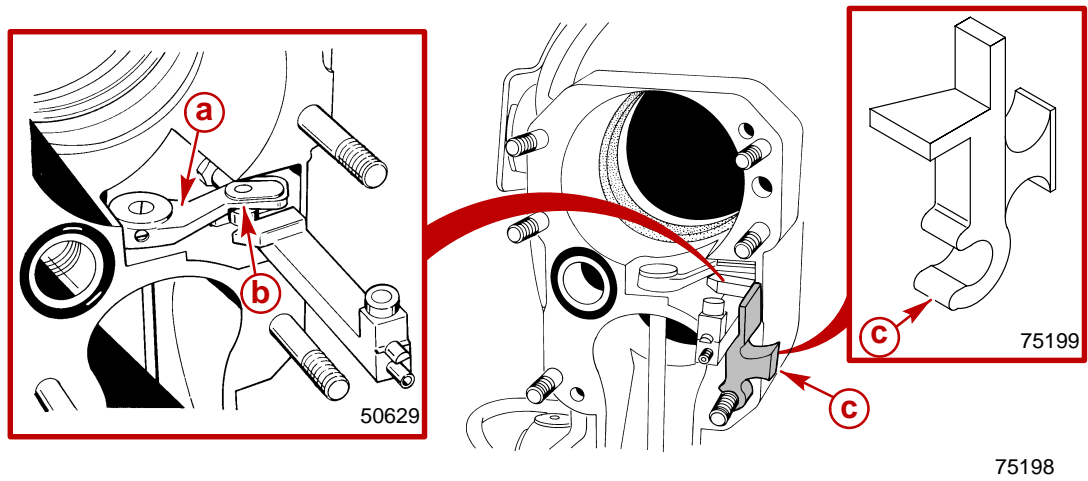

- a** - Shift Shaft Lever
- b** - Roller
- c** - Shift Shaft Slide Stabilizer Tool

Description	Part Number
Shift Shaft Slide Stabilizer Tool	91-809815A1

- Position drive unit shift shaft so that it is straight forward by turning shift shaft **CLOCKWISE** while simultaneously turning propeller shaft **COUNTERCLOCKWISE**.

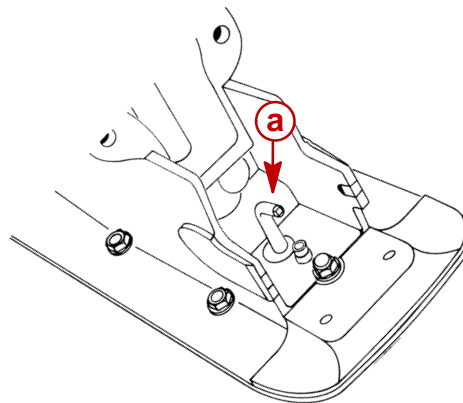

- a** - Drive Unit Shift Shaft

IMPORTANT: Be sure to install RH or LH drive unit on the appropriate transom assembly when making dual engine installations. The LH rotation drive unit can be identified by the decal on the back side of the upper drive shaft housing, which states:

“Alpha One - Counter Rotation”

4. Place gasket on bell housing.

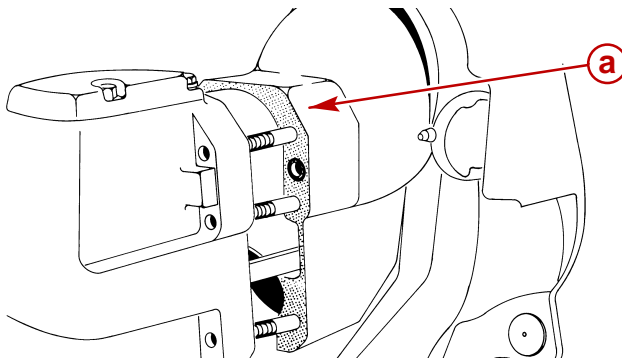

a - Gasket

70010

5. Install sterndrive unit as follows:

- a. Position trim cylinder straight back (over top of acceleration plate). Be careful not to scratch acceleration plate or trim cylinders.
- b. Guide U-joint shaft through gimbal bearing and into engine coupler while simultaneously guiding shift slide into drive shaft housing. Make sure shift slide remains upright and engaged with bell housing shift shaft lever.
- c. Remove Shift Slide Stabilizer Tool.
- d. Slide drive unit all the way into bell housing.

IMPORTANT: If drive unit will not slide all the way into bell housing, ensure that the shift shaft and couplers are positioned properly. Do not force drive unit into position.

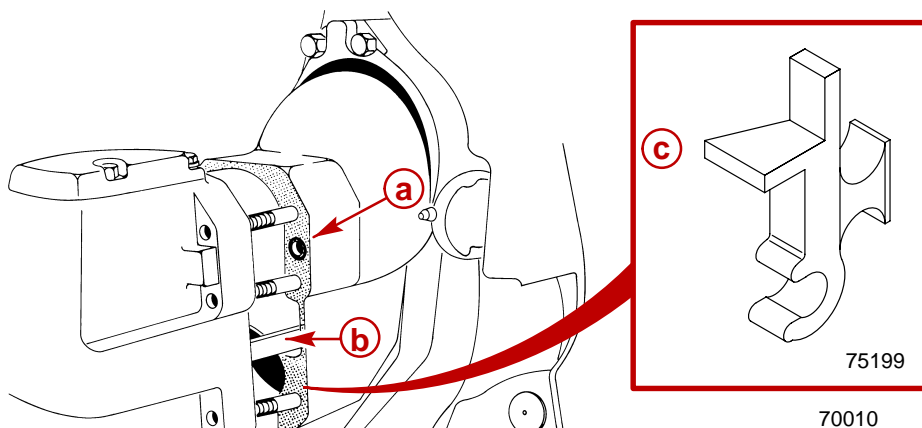

a - Gasket
b - Shift Slide
c - Shift Slide Stabilizer Tool

- e. If necessary, rotate propeller shaft **COUNTERCLOCKWISE** slightly to help align U-joint shaft splines with engine coupler splines. Then slide drive unit all the way into bell housing.
- f. Secure drive unit to bell housings using fasteners as shown. Torque the fasteners.

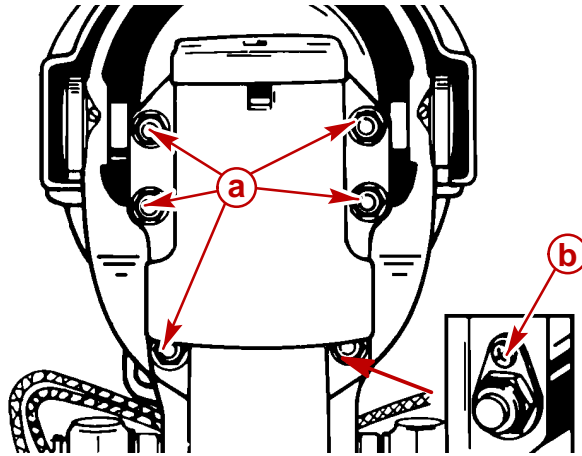

22062

- a** - Locknut And Flat Washers
- b** - Locknut And Continuity Circuit Washer (No Flat Washer At This Location)

Description	Nm	lb-in.	lb-ft
Fasteners	68		50

- 6. Return remote control shift lever to the NEUTRAL position.

Bravo Models

- 1. Lubricate O-ring seals.

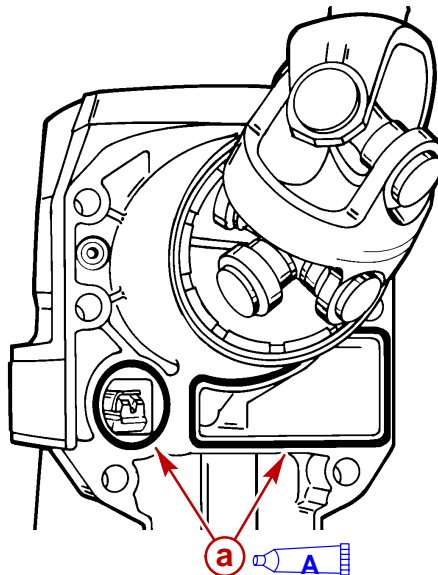

72183

- a** - O-ring Seals

Description	Where Used	Part Number
A 2-4-C Marine Lubricant With Teflon	O-ring Seals	92-825407A3

2. Pull out shift linkage as far as it moves. Jaws will open.

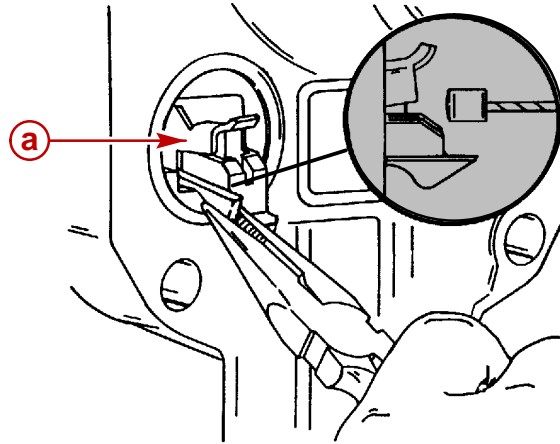

72460

a - Shift Linkage

IMPORTANT: As sterndrive is inserted into sterndrive unit, entry of the bell housing shift cable must be closely checked to make sure cable enters the jaws of shift linkage assembly in the sterndrive.

3. Place remote control in NEUTRAL position.

NOTE: As bell housing shift cable enters the shift linkage assembly, it pushes the assembly back into the sterndrive housing, and the jaw closes, securing the cable, as shown in steps "A", "B" and "C."

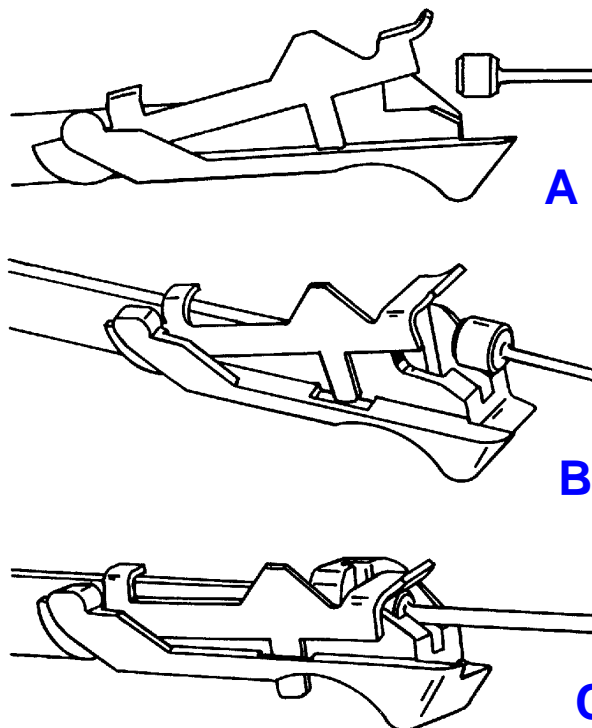

72467

IMPORTANT: If Bell Housing Shift Cable does not line up to properly enter jaws of shift linkage assembly, cable will have to be aligned manually.

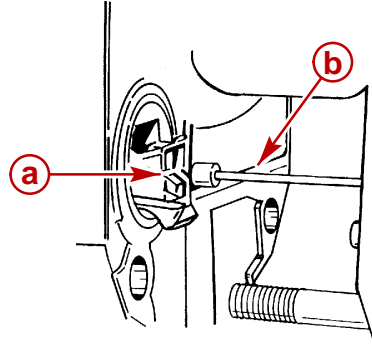

72457

- a** - Shift Linkage Assembly
- b** - Shift Cable

4. Place drive shaft housing in position on bell housing and install sterndrive unit, as follows:
 - a. Remove the nuts from the trim cylinders.
 - b. Position trim cylinders so they point straight backwards.
 - c. Position sterndrive unit so that universal joint shaft aligns with bell housing bore.
 - d. Guide U-joint shaft through bearing in gimbal housing and into engine coupler. Make sure that shift linkage jaws engage the bell housing shift cable assembly.
 - e. If necessary, rotate propeller shaft COUNTERCLOCKWISE slightly (using a propeller) to align U-joint shaft splines with splines in engine coupling, then slide sterndrive unit all the way into bell housing.
5. Secure sterndrive unit to bell housing with 5 flat washers and 6 locknuts and torque.

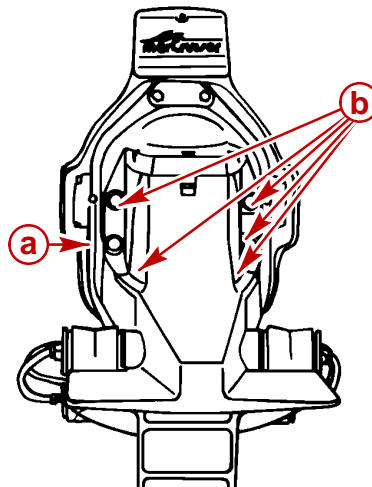

71244

- a** - Locknut Only
- b** - Locknuts And Flat Washers

Description	Nm	lb-in.	lb-ft
Sterndrive-To-Bell Housing	68		50

IMPORTANT: On Bravo One, Two and Three Models, the Trim-In Limit Insert must be properly positioned before installing the trim cylinder anchor pin in the following steps.

6. Ensure that the Trim-In Limit Insert is positioned as shown for the appropriate Bravo model.

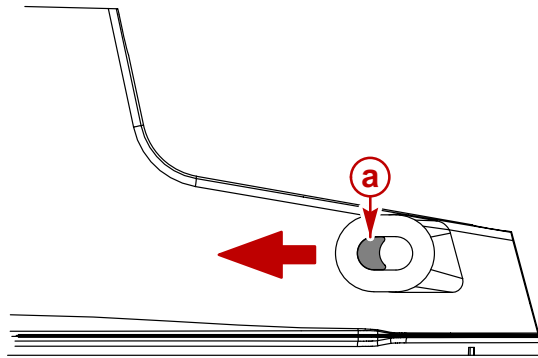

75157

Bravo One and Two (Positioned Forward)

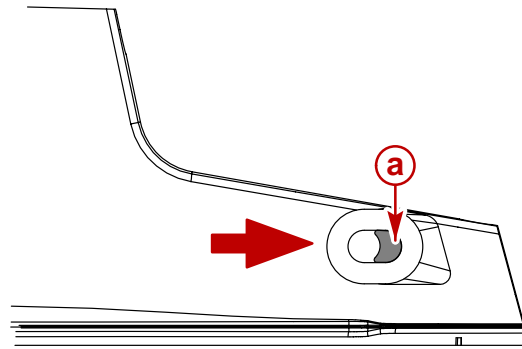

75158

Bravo Three (Positioned Aft)

a - Trim-In Limit Insert

IMPORTANT: The position of the Trim-In Limit Insert on the Bravo Three sterndrive unit should only be changed after the boat has been properly tested. Refer to Trim-In Limit Statement.

IMPORTANT: To aid in installing rubber bushings, use a water and soap solution. **DO NOT** use oil or grease.

All Models

1. Install trim cylinders on aft end of sterndrive unit with hardware as shown.
2. Install plastic caps and tighten hand tight only.

NOTE: Upon installation of hardware apply lubricant to all components except plastic caps.

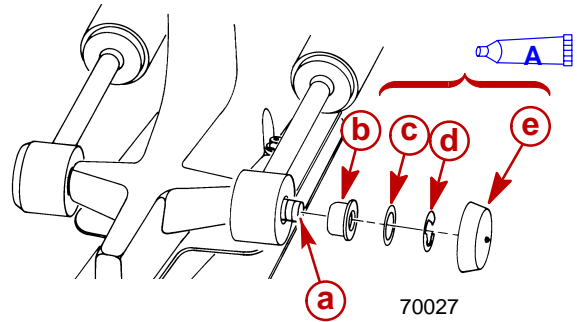
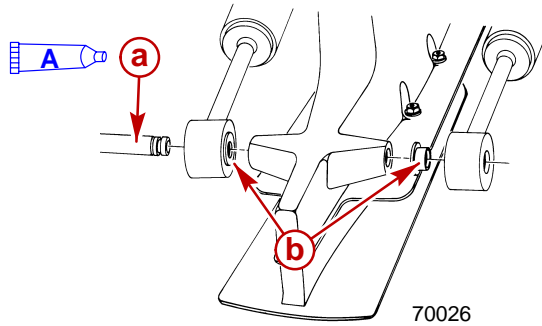

Alpha Models

- a** - Aft Anchor Pin
- b** - Bushings
- c** - Flat Washers
- d** - E-ring Clips
- e** - Plastic Caps

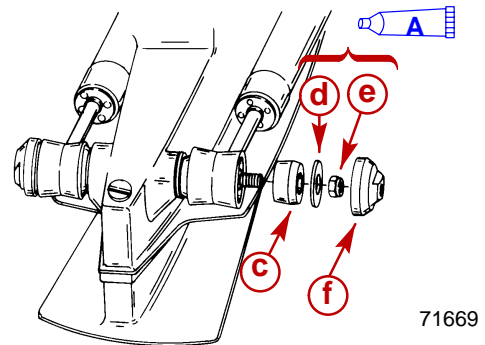
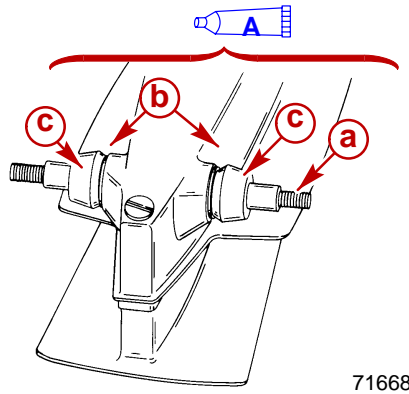

Bravo Models

- a** - Aft Anchor Pin
- b** - Large I.D. Flat Washers (2)
- c** - Rubber Bushings (4)
- d** - Small I.D. Flat Washers (2)
- e** - Locknuts (2)
- f** - Plastic Caps (2)

Description	Where Used	Part Number
A 2-4-C Marine Lubricant With Teflon	Trim Cylinder Hardware	92-825407A3

3. Position the drive unit serial number decal.

Speedometer Connection

Alpha Models

- 1. Raise drive to gain access to area between gimbal housing and sterndrive, immediately above the transom end of the anti-ventilation plate.
- 2. Align plastic slots on male and female portions and insert.
- 3. Push down to secure.

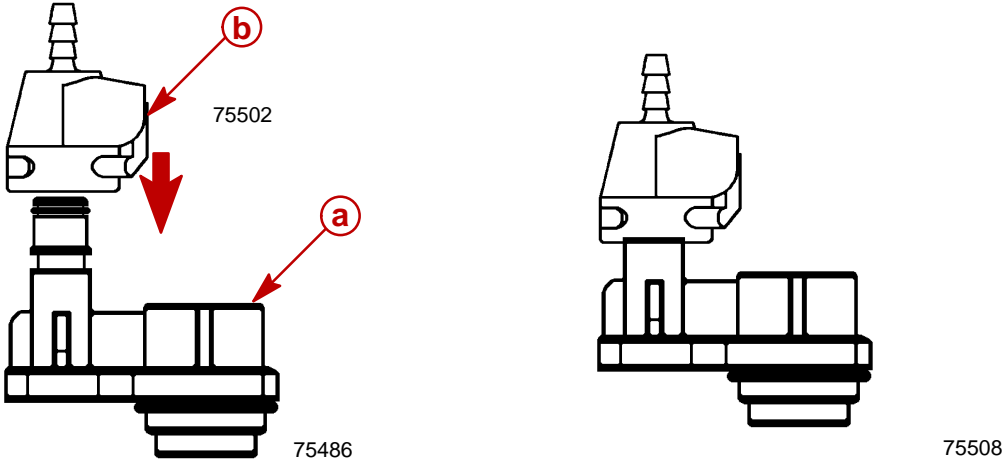

a - Male End Of Speedometer Tube Fitting
b - Female Portion

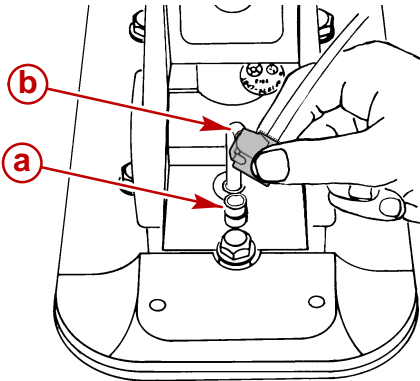

a - Tube Fitting, Male End
b - Topside Portion, Female End

75513

Bravo Models

1. Raise sterndrive to gain access to area between gimbal housing and sterndrive, immediately atop the transom end of the anti-ventilation plate.
2. Insert speedometer tube fitting into opening on topside of anti-ventilation plate, in position shown.

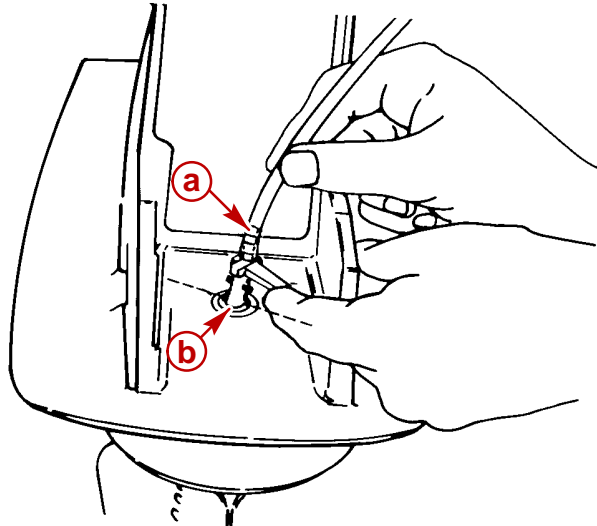

22025

- a** - Tube Fitting
- b** - Opening

3. With fitting fully seated, turn handle to left to a tightly seated position, as shown.

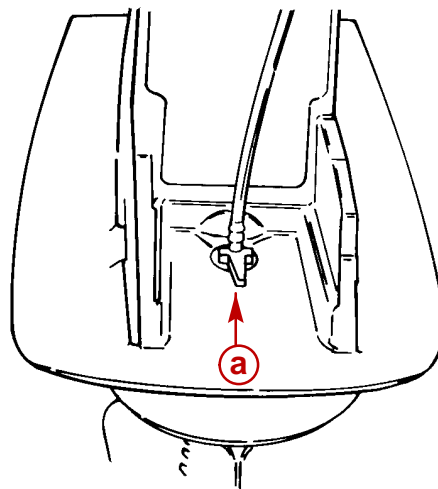

22025

- a** - Handle

Shift Cable Installation

Alpha Models - Drive Unit Installed

IMPORTANT: Shift cable adjustment for a right hand (RH) rotation drive unit is different than the procedure for adjusting a left hand (LH) rotation drive unit. Be sure to refer to the appropriate procedure when performing the following steps.

IMPORTANT: Drive unit must be installed.

IMPORTANT: DO NOT run engine.

1. Remove remote control shift cable and shift assist assembly (if installed).

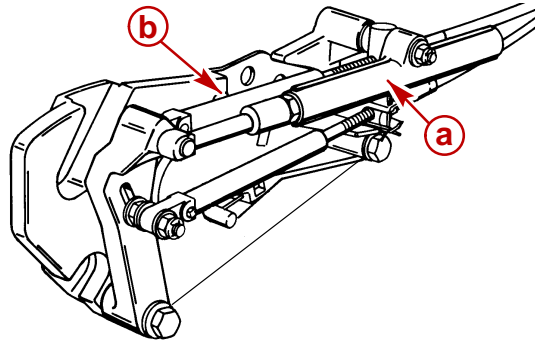

75414

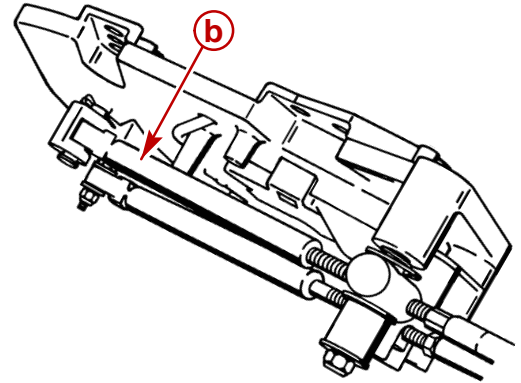

50310

With Shift Assist Assembly Without Shift Assist Assembly

- a** - Shift Assist Assembly
- b** - Remote Control Shift Cable

2. Ensure shift lever adjustable stud is at bottom of slot.

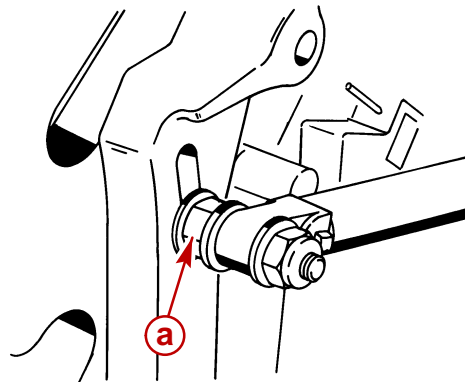

50309

- a** - Adjustable Stud