

# V-Drive

The Velvet Drive® V-Drive marine transmission is a compact, self-contained unit that helps create extra cargo and cabin space by allowing you to move your engines further aft. Because the V-Drive requires no universal joints, a potentially costly maintenance item is completely eliminated.

The deeper offset of the Velvet Drive® V-Drive marine gear allows easy propeller shaft alignment for quick, simple installation. A series of reduction ratios is available. Opposite propeller rotation can be provided for twin engine applications with two engines of like rotation.

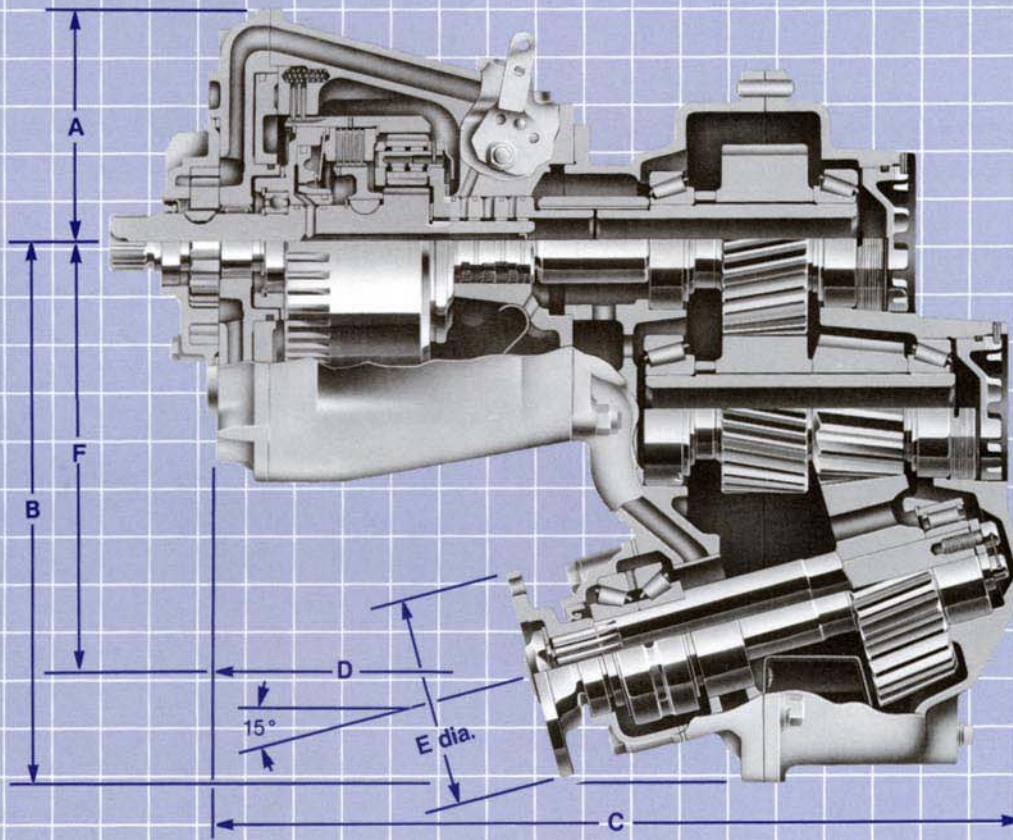

## Dimensions Inches (millimeters)

Models	A	B	C	D	E dia.	F	Reduction
71C (10-04)	5.63 (142.88)	12.72 (323.09)	19.15 (486.41)	7.64 (194.06)	5.00 (127.00)	10.19 (258.83)	1.21:1
						10.19 (258.83)	2.49:1
						10.14 (257.56)	1.51:1
72C (10-05)	5.63 (142.88)	12.72 (323.09)	20.06 (509.52)	8.58 (217.93)	5.00 (127.00)	10.14 (257.56)	1.99:1
						10.19 (258.83)	1.21:1
						10.19 (258.83)	2.49:1
						10.14 (257.56)	1.51:1
						10.14 (257.56)	1.99:1

### Model 71C (10-04) General Information

Available Ratios ..... 1.21, 1.51, 1.99, 2.49 : 1.00  
 Shaft Rotation ..... Specify output shaft rotation to be same as or opposite to engine rotation when ordering  
 Dry Weight ..... 190 lbs. (86.2 kg)

### Model 72C (10-05) General Information

Available Ratios ..... 1.21, 1.51, 1.99, 2.49 : 1.00  
 Shaft Rotation ..... Specify output shaft rotation to be same as or opposite to engine rotation when ordering  
 Dry Weight ..... 203 lbs. (92.1 kg)